



# **INTERNATIONAL RESEARCH CONFERENCE IN HEALTH SCIENCES 2023**

**Innovation, collaboration and experientia:  
For the sustainable development of  
health and well being**

## **Book of Proceedings**

**31<sup>st</sup> March 2023**

**Faculty of Allied Health Sciences  
University of Sri Jayewardenepura**



**Faculty of Allied Health Sciences  
University of Sri Jayewardenepura**

**International Research Conference in Health  
Sciences  
2023**

**“Innovation, collaboration, and experientia: For the sustainable  
development of health and wellbeing”**

**31<sup>st</sup> March 2023**

**University of Sri Jayewardenepura, Sri Lanka**

**Faculty of Allied Health Sciences  
University of Sri Jayewardenepura  
Research Committee**

***Chairperson***

Dr. N.D Withanage

***Secretary***

Dr. R.M.T.B. Abeyratne

***Assistant Secretary***

Dr. Ayomi Dilhari

***Treasurer***

Dr. Kasuni Akalanka

***Assistant Treasurer***

Dr. D.I.G. Rajapaksha

***Committee Members***

Prof. M.D.J. Wijayabandara

Prof. N. R. Samaranayake

Dr. G.U.S Wijesekara

Dr. W.J.A.B.N. Jayasuriya

Dr. M.R.S. Jayathilake

Dr. I.M.P.S. Ilankoon

Dr. H.M.D.R Herath

Dr. G.P.S. Senadheera

Ms. L.C. Damayanthi

Mr. B.A.G Chathuranga

Ms. E.T. Jagoda

## **Organizing Committee**

### ***Conference Chairperson***

Dr. N.D Withanage

### ***Conference Secretaries***

Dr. W.J.A.B.N. Jayasuriya

Dr. R.M.T.B. Abeyratne

Ms. L.C. Damayanthi

Mr. B.A.G Chathuranga

Dr. Ureshani Karunaratne

### ***Committee Members***

Prof. M.D.J. Wijayabandara

Prof. N. R. Samaranayake

Dr. G.U.S Wijesekara

Dr. M.R.S. Jayathilake

Dr. I.M.P.S. Ilankoon

Dr. H.M.D.R Herath

Dr. G.P.S. Senadheera

Dr. Kasuni Akalanka

Dr. Ayomi Dilhari

Dr. D.I.G. Rajapaksha

Ms. E.T. Jagoda

## **Editorial Committee**

Prof. N.R Samaranayake

Dr. N.D. Withanage

Dr. W.J.A.B.N. Jayasuriya

Dr. R.M.T.B. Abeyratne

Dr. Ayomi Dilhari

Ms. L.C. Damayanthi

Mr. B.A.G Chathuranga

Dr. Ureshani Karunaratne

## **Message from the Acting Vice-Chancellor University of Sri Jayewardenepura**



I am delighted to convey this congratulatory message for the “International Research Conference in Health Sciences 2023 (IRCHS 2023)”, the annual research conference of the Faculty of Allied Health Sciences, University of Sri Jayewardenepura.

The theme of this year’s conference, “Innovation, collaboration, and experientia: For the sustainable development of health and wellbeing” emphasizes the importance of novel innovations in the healthcare sector. Research in allied health sciences is a necessity for the development of healthcare setting of any country and it is one of the

ways by which academics can serve the people of the country. Conducting health related research provides opportunity to improve healthcare services while nurturing young scientists to make great scientific discoveries for the betterment of all mankind.

An important event of IRCHS 2023 agenda, “Stories of Young Innovators in Health Sciences” provides the platform for young innovators to publicize their innovations, thereby further strengthening the scope of the conference. It gives me great pleasure to see academics of the Faculty of Allied Health Sciences taking the maximum benefit out of these opportunities as well.

I would like to thank all the international speakers, resource persons and authors for sharing their expertise and valuable experiences in research and dedicating their valuable time and effort to join us at the International Research Conference in Health Sciences 2023. I wish to extend my sincere thanks to the Former Dean, Dean, Chairperson and the Research Committee and the staff of the Faculty of Allied Health Sciences for their immense contribution to make this academic event a great success. I sincerely hope all participants will make the best out of this wonderful opportunity.

**Professor Upul Subasinghe**  
**Acting Vice-Chancellor**  
**University of Sri Jayewardenepura**

## **Message from the Dean Faculty of Allied Health Sciences - University of Sri Jayewardenepura**



It is with great pleasure I present this message to the proceedings of the third research conference organized by the Faculty of Allied Health Sciences (FAHS). The theme for the International Research Conference in Health Sciences (IRCHS) 2023 is “Innovation, Collaboration & Experientia; for the sustainable development of the Health and Wellbeing”.

Amid a flood of rapidly evolving conflicting information, how do we best communicate health science to the community? As a young energetic faculty, FAHS launched its inaugural conference in 2021 to address this concern. The importance of disseminating knowledge in a trustworthy and understandable way is specially relevant to health sciences, since it has a direct impact on health of human beings. The organizing committee has now expanded the collaborations with international professional bodies in the field of Health Sciences to enrich the knowledge of the participants on timely topics.

The theme of the research conference this year expands on, Nursing, Management and Health Promotion; Discovery, Development & Quality Use of Medicine; Health, Nutrition and Laboratory diagnostics, which are of global interest. It will be a platform for researchers to share their findings through oral or poster presentations. The young innovator award competition has become more popular, and the innovations and inventions showcase their talents in diverse fields of Health Science.

With this conference we want to hear your innovative ideas, and experiences on how we can make best use of emerging trends in health sciences for the betterment of mankind. Therefore, we invite the researchers in different fields to collaborate with the FAHS in future research.

I take this opportunity to thank the international professional bodies and the resource panel for their valuable contributions to make the IRCHS 2023 a success. Amidst many challenges the organizing committee has worked hard and tirelessly to make the IRCHS 2023 a success. I congratulate the team and wish the IRCHS 2023 every success.

**Professor D.I. Uluwaduge**  
**Dean**  
**Faculty of Allied Health Sciences**  
**University of Sri Jayewardenepura**

## **Message from the Chairperson Research Committee, Faculty of Allied Health Sciences**



It is with great pleasure I write this message to the conference proceedings of the International Research Conference in Health Sciences 2023 (IRCHS 2023). IRCHS 2023 is an annually held, most significant highlight of the calendar of the Faculty of Allied Health Sciences, which is organized this time for the third consecutive year in hybrid mode. IRCHS 2023 is a platform for academics, undergraduates, postgraduates, and professionals to share the research and knowledge they gain with the world. Moreover,

IRCHS 2023 gathers a great number of researchers from a wide variety of disciplines into a single platform.

The Faculty of Allied Health Sciences Oration will be delivered by Prof. D.I Uluwaduge, Department of Basic Sciences, Faculty of Allied Health Sciences, University of Sri Jayewardenepura. The keynote speech will be delivered by Dr. S.M.K.S Seneviratne, a very senior academic who has been there since the inception of the Allied health degree programmes at the Faculty of Medical Sciences, USJ.

IRCHS 2023 programme included a Pre-Conference workshop on “Innovations and Inventions from Bench to Shelf” which was organized to promote and guide viable innovations and inventions among undergraduates and postgraduates.

The scientific programme includes a symposium on “Sustainable development of health and wellbeing” which will be facilitated by three eminent international speakers from the clinical pharmacy, nursing, and laboratory compliance, which I believe will be very informative for all of us. I am humbled by the support extended by the International Pharmaceutical Federation (FIP) in facilitating international speakers and promoting the symposium flyer among FIP members.

The Young Innovators Award in Health Sciences was also organized by our faculty for the third consecutive year, where the Best Innovator in Health Sciences 2023, and 1<sup>st</sup> and 2<sup>nd</sup> Runners-Up awards were selected through a panel of 15 expert reviewers. The winners will receive awards today at the conference.

We received more than 150 abstracts related to various fields of health sciences, of which 112 were accepted after a rigorous review process. These findings will be shared with us today under themes, of ‘Nursing Management and Health Promotion’, ‘Discovery, Development and Quality use of Medicines’, and ‘Health, Nutrition and Laboratory Diagnostics’.

I would like to appreciate the tireless efforts put in by the secretary, conference secretaries, and committee members, going far beyond the call of duty, so that we could deliver this task successfully. The guidance from the former Dean, Snr. Prof. Sharaine Fernando was a great strength. I greatly appreciate the Dean of FAHS, Prof. D.I Uluwaduge for her unwavering support and cooperation, advice, and guidance in the organization of this event. I am humbled by the support shown by all academic and non-academic members of FAHS who were united in facilitating this conference for all of you.

I wish you to have a fruitful conference with inspiring research ideas.

**Dr. Niroshima Withanage**  
**Conference Chair 2023**  
**Faculty of Allied Health Sciences**  
**University of Sri Jayewardenepura**

## Faculty of Allied Health Sciences Oration

### Herbal Remedies; Myths, Beliefs and Discovering the Truth

#### Prof. Deepthi Inoka Uluwaduge

B. Sc. Special Human Biology (Biochemistry), PhD (Biochemistry)  
Professor, Department of Basic Sciences, Faculty of Allied Health Sciences,  
University of Sri Jayewardenepura



History of medicine is fascinating subject as it unveils man's struggle against disease. From ancient times, man has used plant substances to cure diseases and these remedies are passed from generation to generation based on myths and beliefs. With advancing civilization and changes in disease pattern, researchers explored novel remedies. Researchers attempted to explore novel medicines from herbs and functional foods and considered them as better alternatives to allopathic medicine. In this context, results of four studies conducted by me and my colleagues are discussed below.

Fruits of *Borassus flabellifer* (palmyrah palm, Thal), pods of *Abelmoschus esculentus* (Ladies fingers, Bandakka) were investigated for hypoglycaemic and hypocholesterolaemic effects. The efficacy of two authentic Ayurvedic preparations that are mentioned in Ayurveda pharmacopeia were evaluated against pathogens causing periodontal diseases and eye diseases respectively.

Study 1: This was focused on the commercially valued, but vastly underutilized perishable fruit pulp of palmyrah. In traditional Tamil culture fruit pulp is used to manufacture dried fruit leather called “pinattu”, a popular desert and believed to have many health benefits. Investigations were carried out to assess the hypoglycaemic effect of fruit pulp. Results revealed that fruit pulp has the ability to hinder glucose absorption by inhibiting the  $\text{Na}^+/\text{K}^+$  ATP ase pump of mice intestinal cells. This was due to a novel steroidal saponin flabelliferin-II, that gives bitterness to the pulp. Our next step was to try fruit pulp on newly diagnosed mild diabetics. Before the clinical trials, toxicity studies were conducted with mice, to exclude the toxicity in pulp, since there were documented neurotoxicity in odiyala flour, prepared from kottakilangu (boiled seed shoot of palmyrah). The results revealed that pinattu has the potential to function as a nontoxic hypoglycaemic agent and the anticipated benefit is to obese diabetics. This finding is of commercial significance.

Study 2: This study assessed the hypoglycaemic and hypocholesterolaemic effect of Okra, a delicious green vegetable used in many culinary preparations worldwide. Feeding crude water extract to mice models showed that the fruit of okra has the ability to reduce blood glucose levels and to modulate the blood cholesterol levels favorably. The most important piece of evidence obtained was the heat labile nature of the suspected compound leading to reduced blood glucose levels. Thus, okra have the potential to be used as an antidiabetogenic vegetable if prepared preserving the green colour and it's a heart -friendly vegetable too.

Study 3: Ayurvedic herbal preparations mentioned in authentic text as “Gandusha” (mouth wash) had been proven to be effective in improving oral health. This study was based on the assessment of *in-vitro* anti-microbial activity of a poly herbal preparation consisting the

leaves of *Jasminum officinale* (Saman pichcha), fruits of *Terminalia chebula* (Aralu), stem of *Tinospora cordifolia* (Rasakinda), whole plant of *Desmodium triflorum* (Heen undupiyaliya) and roots of *Glycyrrhiza glabra* (Welmee) against common oral pathogens causing periodontal diseases and dental caries. The aqueous extract had proven antimicrobial activity thus improving oral health.

Study 4: In this study the effectiveness of an Ayurvedic herbal preparation used in the conjunctivitis was tested. This preparation consist of tender stems of *Coscinium fenestratum* (Weniwelgeta), dried stem of *Tinospora cordifolia* (Rasakinda), the dried fruit carp of *Terminalia chebula* (Aralu), fruit carp of *Terminalia bellirica* (Bulu), and dried fruits of *Phyllanthus emblica* (Nelli). Promising results were obtained, and the antibacterial activity of the herbal preparation was greater (considering the zonal inhibition) than the standard antibacterial agents recommended for conjunctivitis.

These two herbal preparations are of commercial significance and has the potential to be developed to novel effective antimicrobial medications due to emerging resistance for existing antimicrobial agents.

In my journey as a scientist, I was able to establish the scientific basis for the beliefs that lead to historical use of plant-based products as preventive or curative agents. I will continue the journey in discovering many more.

## **Keynote Speech**

### **Addressing unconscious bias in healthcare to promote sustainable health and wellbeing of women**

**Dr. Sujatha Seneviratne**

Senior Lecturer

Department of Nursing and Midwifery

Faculty of Allied Health Sciences

University of Sri Jayewardenepura



Unconscious bias refers to ways people draw assumptions about individuals and groups and come to conclusions without being consciously aware of it. It is also known as implicit bias, which is triggered when people or situations are quickly judged. Evidence is available on unconscious biases related to many professions including health care professionals, despite their strong moral and ethical obligations towards others. These biases have been demonstrated to have a significant impact on the quality of care. Further, these biases are not different from the biases within general public. Unconscious or implicit biases based on a variety of factors; age, socio-economic status, body weight, gender, race or sexual orientation and most importantly on vulnerable groups including women have been reported.

This address aims to highlight the unconscious biases perceived by women subjected to intimate partner violence seeking healthcare, within their experiences of healthcare encounters. Strategies to unlearn and reduce explicit biases and improve patient outcomes towards sustainable health and wellbeing will also be discussed. It is recommended to include the topic of unconscious bias in nursing / health sciences curricula and create educational opportunities that challenge nurses / healthcare professionals to discover and limit the unconscious bias towards others as a step towards creating an equitable environment in health care.

# Inauguration Ceremony

Programme 31<sup>st</sup> March 2023

- |                                |                                                                                                                                                        |
|--------------------------------|--------------------------------------------------------------------------------------------------------------------------------------------------------|
| <b>8.25 a.m. - 8.30 a.m.</b>   | University Anthem                                                                                                                                      |
| <b>8.30 a.m. – 8.35 a.m.</b>   | Welcome address by the Chairperson, Research Committee, Faculty of Allied Health Sciences                                                              |
| <b>8.35 a.m. – 8.45 a.m.</b>   | Address by The Dean, Faculty of Allied Health Sciences, USJ                                                                                            |
| <b>8.45 a.m. – 8.55 a.m.</b>   | Address by Guest of Honour, The Vice Chancellor, USJ                                                                                                   |
| <b>8.55 a.m. – 9.10 a.m.</b>   | Address by Chief Guest Snr. Prof. Susirith Mendis, Senior Professor of Physiology, Faculty of Medicine, General Sir John Kotelawala Defence University |
| <b>9.10 a.m. – 9. 55 a.m.</b>  | Faculty of Allied Health Sciences Oration<br>Prof. D.I. Uluwaduge, Department of Basic sciences Faculty of Allied Health Sciences                      |
| <b>9.55 a.m. – 10.00 a.m.</b>  | Vote of Thanks by the Secretary, Research Committee, Faculty of Allied Health Sciences                                                                 |
| <b>10.00 a.m. – 10.20 a.m.</b> | Refreshments                                                                                                                                           |

## Scientific Programme – IRCHS 2023

|                         |                                                                                                                                                                                                                                                                                                                                                                                                                                                                                                                  |                                                                                                                                             |                                                                                                                                   |
|-------------------------|------------------------------------------------------------------------------------------------------------------------------------------------------------------------------------------------------------------------------------------------------------------------------------------------------------------------------------------------------------------------------------------------------------------------------------------------------------------------------------------------------------------|---------------------------------------------------------------------------------------------------------------------------------------------|-----------------------------------------------------------------------------------------------------------------------------------|
| 11.00 a.m. – 11.30 a.m. | <p><b>Keynote Address</b><br/> <i>Addressing unconscious bias in healthcare to promote sustainable health and wellbeing of women</i><br/> <b>Dr. Sujatha Seneviratne</b><br/>                 Department of Nursing and Midwifery<br/>                 Faculty of Allied Health Sciences<br/>                 University of Sri Jayewardenepura, Sri Lanka</p>                                                                                                                                                   |                                                                                                                                             |                                                                                                                                   |
| 11.30 a.m. – 1.30 p.m.  | <p><b>Symposium on “Sustainable development of health and wellbeing”</b><br/>                 Chairperson: Prof. N.R. Samaranyake</p>                                                                                                                                                                                                                                                                                                                                                                            |                                                                                                                                             |                                                                                                                                   |
| 11.30 a.m. – 12.10 p.m. | <p><b>Contemporary challenges for the nursing and midwifery professions</b></p> <p><b>Prof. Leanne Boyd</b><br/>                 Adjunct Professor (Monash University &amp; La Trobe University)<br/>                 Fellow Australian College of Nursing<br/>                 Executive Director-Learning and Teaching (Eastern Health)<br/>                 Chief Nursing and Midwifery Officer (Eastern Health)</p>                                                                                          |                                                                                                                                             |                                                                                                                                   |
| 12.10 p.m. – 12.50 p.m. | <p><b>Sustainability environment and planetary health: Role of the pharmacists, pharmaceutical scientists and pharmacy educators</b></p> <p><b>Dr. Shellyza Moledina Sajwani</b><br/>                 MPharm, PharmD, RPh<br/>                 Co-Chair, FIP Environmental Sustainability Policy Committee (2023)<br/>                 Co-Founder/Co-Chair - Canadian Association of Pharmacy for the Environment (CPhE)<br/>                 Board Member - Pharmacists Without Borders Canada (PSF Canada)</p> |                                                                                                                                             |                                                                                                                                   |
| 12.50 p.m. – 1.30 p.m.  | <p><b>Laboratory safety and compliance, with a focus on the human element</b></p> <p><b>Ms. Megan Coleman</b><br/>                 Compliance Manager<br/>                 Department of Microbiology &amp; Immunology<br/>                 University of Otago</p>                                                                                                                                                                                                                                              |                                                                                                                                             |                                                                                                                                   |
|                         |                                                                                                                                                                                                                                                                                                                                                                                                                                                                                                                  |                                                                                                                                             |                                                                                                                                   |
| 1.30 p.m. – 2.30 p.m.   | <p><b>Oral Presentations</b></p>                                                                                                                                                                                                                                                                                                                                                                                                                                                                                 |                                                                                                                                             |                                                                                                                                   |
|                         | <p><b>Session I - Oral</b><br/>                 Nursing, Management &amp; Health Promotion</p> <p>Chairperson<br/>                 Dr. M.K.D.L. Meegoda</p>                                                                                                                                                                                                                                                                                                                                                      | <p><b>Session II – Oral</b><br/>                 Discovery, Development &amp; Quality use of Medicines</p> <p>Dr. W.J.A.B.N. Jayasuriya</p> | <p><b>Session III – Oral</b><br/>                 Health, Nutrition &amp; Laboratory Diagnostics</p> <p>Dr. G.U.S. Wijesekara</p> |
|                         | Presentation identifier                                                                                                                                                                                                                                                                                                                                                                                                                                                                                          | OP1,OP2,OP3,OP4,OP5                                                                                                                         | OP12,OP13,OP14,OP15,OP16<br>OP24,OP26,OP27,OP28                                                                                   |
| 2.30 p.m. – 3.30 p.m.   | <p><b>Oral Presentations</b></p>                                                                                                                                                                                                                                                                                                                                                                                                                                                                                 |                                                                                                                                             |                                                                                                                                   |
|                         | <p><b>Session IV - Oral</b><br/>                 Nursing, Management &amp; Health Promotion</p> <p>Chairperson<br/>                 Dr. M.R.S. Jayathilake</p>                                                                                                                                                                                                                                                                                                                                                   | <p><b>Session V– Oral</b><br/>                 Discovery, Development &amp; Quality use of Medicines</p> <p>Dr. H.M.D.R. Herath</p>         |                                                                                                                                   |
|                         | Presentation identifier                                                                                                                                                                                                                                                                                                                                                                                                                                                                                          | OP6,OP7,OP8, OP9,OP10                                                                                                                       | OP17, OP18, OP19, OP20, OP21, OP22                                                                                                |
| 3.30 p.m. – 4.30 p.m.   | <p><b>Poster Presentations</b></p>                                                                                                                                                                                                                                                                                                                                                                                                                                                                               |                                                                                                                                             |                                                                                                                                   |
|                         | Session I – Poster                                                                                                                                                                                                                                                                                                                                                                                                                                                                                               | Session II – Poster                                                                                                                         | Session III – Poster                                                                                                              |

*“Innovation, collaboration, and experientia: For the sustainable development of health and wellbeing”*

|                                |                                                                                 |                                                                                              |                                                                                     |
|--------------------------------|---------------------------------------------------------------------------------|----------------------------------------------------------------------------------------------|-------------------------------------------------------------------------------------|
|                                | <i>Nursing, Management &amp; Health Promotion</i>                               | <i>Discovery, Development &amp; Quality use of Medicines</i>                                 | <i>Health, Nutrition &amp; Laboratory Diagnostics</i>                               |
| <i>Chairperson</i>             | <i>Dr. I.M.P.S. Hankoon</i>                                                     | <i>Dr. G.P.S.G. Senadheera</i>                                                               | <i>Dr. D.I.G Rajapaksha</i>                                                         |
| <i>Presentation identifier</i> | PP1, PP4, PP5, PP6, PP7, PP8, PP9, PP10, PP11, PP13, PP14,PP24                  | PP 29, PP30,PP31, PP32, PP33,PP34,PP35,PP36,PP37, PP38,PP39,PP40, PP41, PP42,PP43,PP44, PP45 | PP63,PP64,PP65,PP66,PP67, PP68,PP69,PP70,PP71, PP72,PP73                            |
| <b>4.30 p.m.– 5.30 p.m.</b>    | <b>Poster Presentations</b>                                                     |                                                                                              |                                                                                     |
|                                | <b>Session IV – Poster</b><br><i>Nursing, Management &amp; Health Promotion</i> | <b>Session V – Poster</b><br><i>Discovery, Development &amp; Quality use of Medicines</i>    | <b>Session VI - Poster</b><br><i>Health, Nutrition &amp; Laboratory Diagnostics</i> |
| <i>Chairperson</i>             | <i>Mrs. L.C. Damayanthi</i>                                                     | <i>Dr. Ureshani Karunaratne</i>                                                              | <i>Dr. K.A.A. Dilhari</i>                                                           |
| <i>Presentation identifier</i> | PP2,PP15,PP16,PP17, PP19,PP20,PP21,PP22, PP23,PP25,PP26,PP27,PP28               | PP46,PP47,PP49,PP50, PP51, PP54,PP55, PP56,PP57,PP58,PP59,PP60, PP61, PP 85                  | PP74,PP75,PP76,PP77,PP78 PP79,PP80,PP81,PP82, PP83,PP84, PP86                       |
| <b>5.30 p.m. – 6.00 p.m.</b>   | <b>Awards Ceremony &amp; Closing Remarks</b>                                    |                                                                                              |                                                                                     |
|                                | <b>Young Innovators Award 2023</b><br><b>Best Oral and Poster Presentations</b> |                                                                                              |                                                                                     |

## **Young Innovators Award Reviewers – International Research Conference in Health Sciences 2023**

Senior Prof. Sagarika Ekanayake  
Department of Biochemistry  
Faculty of Medical Sciences, USJ

Senior Prof. Aloka Pathirana  
Department of Surgery  
Faculty of Medical Sciences, USJ

Senior Prof. Renu Wickremasinghe  
Department of Parasitology  
Faculty of Medical Sciences, USJ

Prof. Rasika Perera  
Department of Biochemistry  
Faculty of Medical Sciences, USJ

Prof. Lohini Athiththan  
Department of Biochemistry  
Faculty of Medical Sciences, USJ

Prof. R.B. Marasinghe  
Department of Medical Education  
Faculty of Medical Sciences, USJ

Prof. Chinthika Gunasekara  
Department of Microbiology  
Faculty of Medical Sciences, USJ

Prof. Bimalka Seneviratne  
Department of Pathology  
Faculty of Medical Sciences, USJ

Prof. Buddhika Priyadarshani  
Department of Medical Laboratory  
Sciences  
Faculty of Allied Health Sciences,  
USJ

Senior Prof. Sampath Gunawardena  
Department of Physiology  
Faculty of Medicine, University of  
Ruhuna

Dr. Anushka Rajapaksha  
Instrument Centre  
Faculty of Applied Sciences, USJ

Dr. Chandrike Ponnampereuma  
Consultant Cardiologist  
Colombo South Teaching Hospital

Dr. Roshan Thotagamuge  
Department of Nanoscience  
Technology  
Faculty of Technology, Wayamba  
University of Sri Lanka

Dr. Uthpali Mannapperuma  
Department of Pharmacology  
Faculty of Medicine, University  
of Colombo

Dr. Hiruni Harischandra  
Genetics and Molecular Biology  
Unit  
Faculty of Applied Sciences, USJ

## **Story of Young Innovators in Health Sciences**



### **Innovations to prevent Mosquito Breeding in Urban Built Environment in Sri Lanka**

Chameera Udawattha

*Department of Estate Management and Valuation, University of Sri Jayewardenepura, Sri Lanka*

*Corresponding Author: udawatthe@gmail.com*

#### **Overview of your research or innovation**

According to Jayadas et al., 2021, recent outbreaks of Aedes aegypti-borne disease have been associated with an upsurge in built environments in and around urban areas, including Colombo. These environments are believed to offer ideal breeding conditions for mosquitoes and increase the likelihood of human-vector contact. Therefore, enhancing the built environment could serve as a long-term solution for mitigating the threats posed by this vector.

Field experiments were conducted in the urban area of Colombo to assess how mosquitoes grow within well standardize built environment in Colombo areas (Nirmani et al., 2019). And the initial study found that Aedes types mosquitoes are growing within plumbing systems in a house (Louis et al., 2016; Schmidt et al., 2011; Sirisena & Noordeen, 2016; Tissera et al., 2016; Zellweger et al., 2017). This study was conducted to innovate a series of new products to stop mosquito breeding in urban areas. Finally, these products are ready to produce at a mass scale to stop mosquito breeding in urban areas of Colombo.

There were significantly more Aedes types mosquitoes that were trapped, killed or stopped breeding by the novel equipment made by this invention. Increasing sampling frequency from every house that this device was fixed indicates that many mosquitoes have travelled through the septic tank vent and are trapped within the vent trap developed by this study. Further studies should be conducted to develop these inventions to suit plumbing and to make them more user-friendly to the Sri Lankan market.

**Index Terms—Aedes aegypti, Innovation, Mosquito controlling,**

**Purpose/objectives of the research**

1. To find methods of mosquito breeding in well-developed urban context.
2. To find suitable passive remedials to stop man made mosquito habitats.
3. To develop new innovations and Publicly available them by making them practically homemade equipment.

**Method(s)**

Case-control studies will be carried out throughout the process of the invention of the device to assess the magnitude of the relationship between an exposure and its consequent outcome i.e. its design quality (Snetselaar et al., 2014). The case-control studies will focus on how Mosquitoes react to different external stimuli to manipulate and develop smart design concepts to eradicate penetration to the indoors(Udawattha & Ariyawansa, n.d.). As shown in Figure 1 several products and prototypes were developed and tested their productivity by measuring the numbers of mosquito killings and the effectiveness of stopping them from laying eggs.

The mosquito *Aedes aegypti* (Linnaeus) is the major vector of dengue fever and has adapted well to life in cities. Historically, it has been assumed that larvae develop best in “clean” water, with early findings reporting that they were never discovered in sewage or cesspools. Adult *Aedes aegypti* mosquitoes exiting septic tanks in Sri Lanka and India(*Dengue Mosquito Plays Dirty, Starts Breeding in Drain Water | Kolkata News - Times of India*, n.d.; Udawattha & Ariyawansa, n.d.).

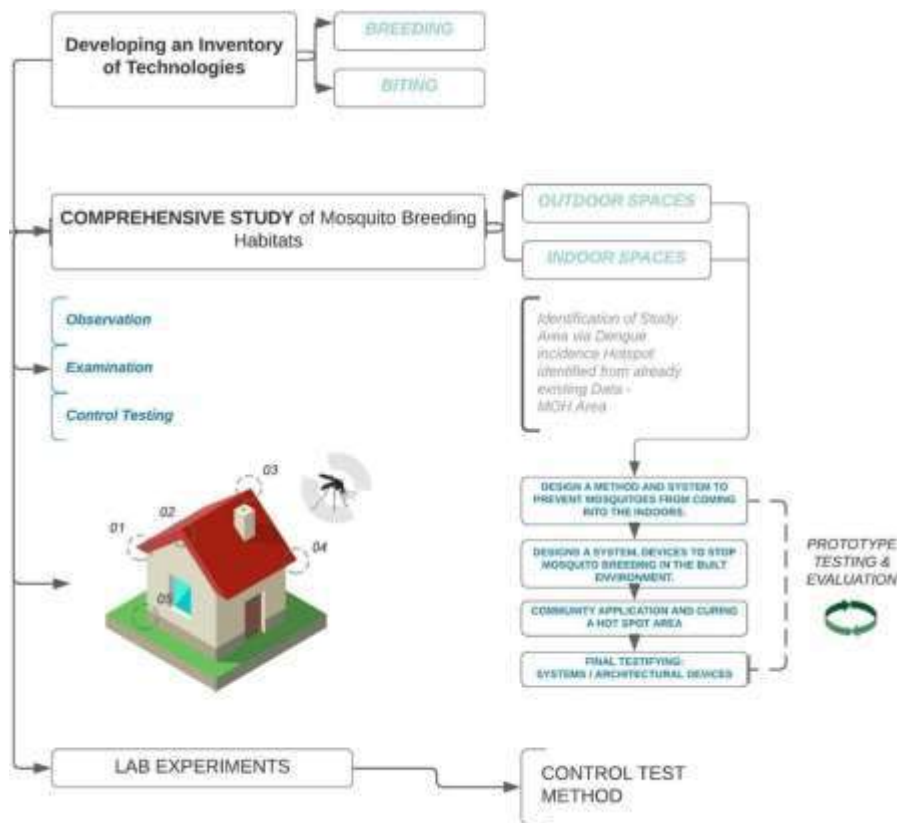
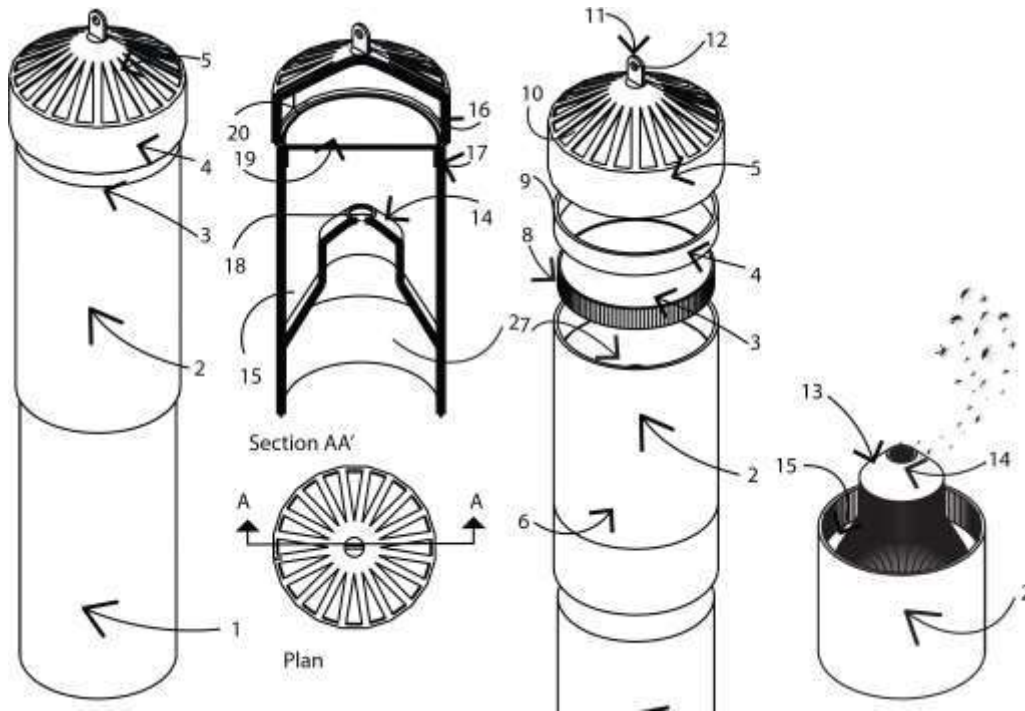

Figure 1: Research Method

## Findings

1. Vent trap
2. Mosquito Trap for drainage gully interceptor
3. Anti-Mosquito gully for bathrooms



*Figure 2: Vent trap details*

### **Vent trap (patent pending - Patent Application No. 21820)**

The typical vent cap is proving an easy path for mosquitoes to fly away from the septic tank and wastewater pit. As a result, the purpose of this innovation shown in figure 4 is to capture flying mosquitos and keep them until they die. The innovation is constructed in such a manner that it is extremely easy clean and reinstall the trap without incurring any additional costs. The innovation is made up of three parts.

Figure 2 is a perspective view of the vent trap. [1] Shows the vent pipe fixed to the septic tank or water tank coming in many standard diameters of two inches (2”), three inches (3”), three and a half inches (3 1/2”), and four inches (4”). [2] is the mosquito trap and the dead mosquito containing bawl to be fixed with mechanical joint typically larger than the standard vent pipe sizes of two inches (2”), three inches (3”), three and a half inches (3 1/2”), and four inches (4”). [3] shows the mosquito net fixed discs mechanically fixed to the vent trap. [4] shows the vent cap stop bats and birds from destroying the mosquito trap. [5] shows the vent opening to remove toxic air from the septic tanks and wastewater pits. [6] the revolving mechanical grew, [7] the mosquito trapping bawl [8]the mosquito net holding ring and [9] the net fixing ring with mechanical elastic ring. [10] shows the vent opening made by the similar thickness of the vent trap out cover. [11] shows the vent trap removing hanger to remove the trap and clean.

[12] shows the hole in the middle of the hanger to send a line and remove the vent trap from the vent pipe. [13] shows the angle shape trap helps to trap running mosquitoes [14] shows the conical opening to remove toxic air and let mosquitoes fly away [15] is the space for dead mosquitoes to store [16] is the detailed version of the mechanical fixing device of the vent cap [17] shows the mechanical grew connecting the trapping net and the vent cover. [18] is the smaller opening size of smaller than the vent pipe. [19] shows the mosquito net made out of three materials such as 1. Plastic net 2. Stainless steel 3. Polyvinyl chloride The mosquito net shown in [19] are already available in the market and not claiming in this invention. [20] shows the grew for installing the device.

The mosquito trap provides a safe channel for toxic air to be evacuated from the pipe while also trapping mosquitoes that are flying away. The second item is a mosquito net fastened to a circular drum with a grew that must be removed and replaced with a fresh net. The third feature is the circular vent cover, which prevents bats and birds from damaging the mosquito trap and devouring dead mosquitos. The innovation is available in a variety of standard diameters including two inches (2”), three inches (3”), three and a half inches (3 1/2”), and four inches (4”). The pipe hole channeling from the septic tank and wastewater tanks was then repaired. Figure 4 creates an unidentified trap for producing mosquitoes. As a result, this is a much-needed remedy for preventing dengue and other mosquito-borne illnesses in Sri

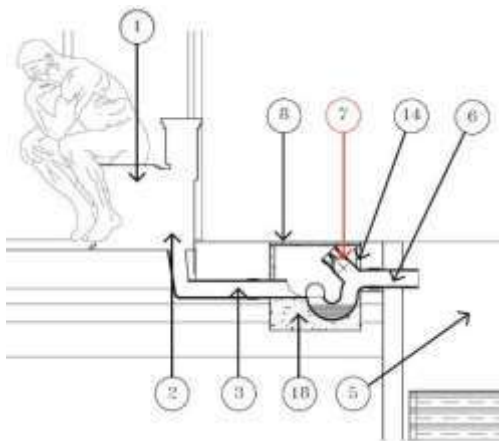

Figure 3: Interceptor gully mosquito trap

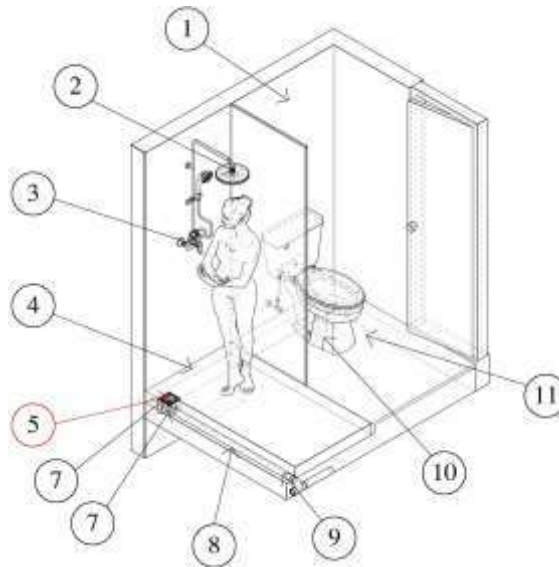

Figure 4: Anti mosquito bathroom gully

#### Interceptor gully mosquito trap

Figure 4 is a sectional image of the entire septic tank system and its shows how this invention can be fixed into the interceptor gully. [1] shows the commode, the source of misquotes to lay their eggs. [2] is the immediate “P” trap or the “S” trap stopping mosquitoes from coming inside the house via the septic tank system? [3] shows the pipe channel the sewer into the septic tank from the commode. This usually empty during the non-using time. [5] shows the sewer collection tank system, usually sewer collected to one chamber and water penetrated to the other tank chamber. This is the cradle of mosquitoes where eggs hatch and start flying to move away from the septic tank. [6] shows the pipe connected to the interceptor, this is the nearest path for mosquitoes to move away from the septic tank. [7] shows the full set of the invention. [8] shows the drainage gully cover usually made out of concrete,

cast iron or checker plate. Most of the time mosquitoes used voids in the cover to fly away from the septic tank.

Figure 4 is a perspective view of a bathroom and how this device is fixed into the bathroom. [1] Shows the entire bathroom as one-unit system. [2.] Shows the showerhead, a major source of water coming into this type of bathroom gully. [3.] Shows the shower tap where the second source of the water coming into the bathroom gully. [4.] Shows the floor of the bathroom usually slanted into the bathroom gully. Therefore, its less chance of water stagnating on top of the bathroom floor. [5.] Shows the void of the bathroom floor for this invention to be fixed. [6.] Shows the level difference between the bathroom floor and the gully cover. The gully cover should be fixed lower than the bathroom floor level to remove excessive water stagnation. [7.] Shows this invention and how this invention could be fixed into the bathroom floor. [8.] Shows the wastewater pipe removing excessive wastewater from the bathroom gully. This helps to float mosquito eggs into the wastewater tanks. [9.] Edge of the wastewater pipe connecting the out pipe system which connects the wastewater tank into the bathroom. [10.] The commode of the bathroom also another source of wastewater coming into the gully. [11.] Shows the floor of the other side of the bathroom. Usually, bathrooms have one or two of these types of gully and they can be located according to the slope of the bathroom.

### **Anti-Mosquito gully for bathrooms Patent No. 21857**

Following the present invention a mosquito barrier, for used in bathrooms gully. The mosquito barrier comprises a basket having a support collar, the collar being engageable with a closable cover fixed funnel basket outlet. The funnel may float water into a bend. The bend is fixed into the funnel as one system and the edge of the bend has a capping to tight the closable cover. The closable cover is comprised of a stainless steel/aluminium half-ring to load the cover downward and a mosquito net to remove excessive water coming through the gully. The closable cover is connected to the funnel and the bend by using a PVC mechanical hinge. The hinge is not claimed in this invention. The basket of the present invention comprises walls made of a material having a plurality of openings for drainage of water. The basket is connected to a funnel which is an interconnected system. And the funnel is also attached to a bend where the edge of the bend is angled to support to closable cover. The closable cover openings are a new invented part of the present invention. Is the size of the bent edge. There is a small half circle shape opening at the lower section of the closable cover with, a PVC mesh or net fabric, defining openings, through which an adult mosquito may not pass, is substituted for the material having a plurality of openings. But this opening should accommodate excessive water to be removed from the gully. The present invention is designed in a way to be fixed into any existing bathroom by removing the gully cover. Or this invention can be fixed into new construction by adjusting the supportive PVC pipe connection. The device can be removed and then cleaned outside of the gully and reconnected later. Removable properties of this invention help to maintain it in long run and help to reduce the replaceable cost of this invention. The present invention would protect against the emergence of mosquitoes or their eggs that have entered a drainage or stormwater system at an unprotected point down- stream and are then flushed downstream by the natural course.

A mosquito trap is offered for use in drainage gully intercep- tors and other water drainage systems. The interceptor gully is a device developed by the Roman civilization to stop the septic

tank and wastewater tank contamination. The mosquito trap is intended to keep adult mosquitoes from flying away from the septic tank and wastewater pits (*see the figure 6*). Furthermore, the mosquito trap prevents mosquitoes hatching from downstream eggs from emerging via a drainage gully interceptor basin protected by the present invention.

The trap is made with mesh, PVC funnel and PVC cover. The trap works as the cover cap for a typical PVC or clay interceptor. Which can be fixed after constructing the drainage gully. And then Sugar-fermenting yeast as an organic source of carbon dioxide to attract the mosquitoes should be placed inside the trap to attract mosquitoes to die inside the invented trap. The interceptor, drainage gully interceptor or the mosquito attracting soup is not claimed in this invention. The technology is developed with an easy tech concept where a lament can produce this trap at home and stop mosquito breeding.

### **Mosquito Trap for drainage gully interceptor - Patent No 21855**

The unique device is designed to prevent mosquitoes from laying eggs in the bathroom gully as well as mosquitoes from entering the bathroom from the wastewater tank. The device shown in figure 5 is designed to fit into existing bathrooms as well as modify and fit into new bathroom construction. PVC or plastic materials are used to construct the device. To obtain gravitational force, only a few components composed of stainless steel or aluminum are used.



*Figure 5: Prototype design of interceptor gully trap*

The device shown in Figure 5 operates via passive approaches and does not require any mechanical energy. Another benefit is that this gadget can be made from recycled plastic bottles and PVC pipe fittings. The device will next be installed in the bathroom gully, which is normally four inches (100mm) in diameter. The idea allows running water to float to the gully, and the force water floating water operates the door. In the event of a jam or routine maintenance, the gadget can be removed and cleaned. Also, even if the closable door is locked or not functional, there is a safe system to evacuate excess water.

Following the present invention a mosquito trap, for use in drainage gully interceptors, is provided. The mosquito trap comprises three components. A funnel letting mosquitoes come into the trap. A basket filled with mosquito attracting soup (not claimed in this invention) and the net to stop mosquitoes flying away from the trap. The trap is designed to replace the cap of the interceptor and fixed to the interceptor. The invention should be kept inside the gully as other mosquito-eating animals such as bats birds and geckos.

The funnel in the present invention is conical in shape and comprises a small opening for mosquitoes to fly away from the septic tank or the wastewater pit, such that the funnel fits within the covering PVC cylinder fixed to the interceptor opening. The funnel and the PVC cover is embodied together and removable from the interceptor when needed to clean. The funnel and the PVC cylinder covering should be manufactured by using black colour to attract more mosquitoes to the trap. And there should be enough opening for them to smell the mosquito attracting soup, carbon dioxide and methane trapped within the gully. The funnel should be fixed to the basket PVC cylinder shape covering in a way to accommodate mosquito attracting soup to be kept. The invention is designed in a way to keep provision for extra space for attractants to be kept inside the trap.

### **Conclusions**

The novel approaches described in this research may offer advantages over current vector management techniques aimed at significantly reducing dengue mosquito (*Aedes aegypti*) populations. The methods that can be used to halt mosquito migration from the source to people. However, these invention series assist in preventing mosquito transmission from the womb to the human. Control study techniques were used to carry out the investigation. Following the primary investigation into the cause of mosquito breeding in well-established urban environments, several inventions were made.

The three primary innovation steps—initial research, product creation, and prototype testing and validation—were carried out in stages. The study's findings indicate that because newly developed traps affect how animals procreate, it is better to prevent sickness than to treat it. The trap may also be a useful instrument in integrated vector control to provide protection around inhabited metropolitan areas and public areas. It would be necessary to produce these technologies on a big scale and make them accessible to the general people in order to reduce Dengue vector populations and disease transmission. Even with these slight adjustments, the trap's low cost makes it a workable addition to the current Dengue vector control techniques. Large-scale field investigations with epidemiological results appear to be the research's next logical step. Additional field validations will be required to investigate and enhance the lure of the trap in a more natural environment.

### **Practical Implications – what can be learned from this project?**

This initiative has been started in Sri Lanka to prevent mosquito breeding in a highly developed urban environment. The majority of these advancements are also created to be produced at home rather than a factory. These developments benefit society, not business. Further research should be done, nevertheless, to prevent mosquito breeding in other ways in the future.

### **Novelty**

Making this innovation accessible to the general public is what makes it novel. Instead of using sophisticated resources, these innovations can be created with throwaway materials. Additionally, the discovery of the many mosquito habitats and the development of techniques to prevent breeding were the best innovations for passively resolving the mosquito and dengue issues. As a result, these inventions are sustainable for a nation like Sri Lanka and use less energy.

**Benefit to the society**

Reducing vector concentrations will lessen the likelihood of future epidemics as well as the nuisance of other urban pest mosquitoes biting people. In addition, most domestic environment changes, such as easier access to drinkable water and cleaner living circumstances, will have a variety of other social and health advantages by reducing human interaction with mosquitoes. Delivering these urban enhancements should be considered as an additional vector-control measure to those interventions provided through the health sector, such as space spraying or larviciding, in addition to benefits for urban development.

## Story of Young Innovators in Health Sciences



### **Holistic Assessment of Cancer Pain: Development and Validation of a Holistically based, Culturally-adapted Follow-up Pain Assessment Diary for Patients with Cancer Pain in Sri Lanka**

Edirisinghe NP<sup>1\*</sup>, Makuloluwa PTR<sup>2</sup>, Amarasekara AATD<sup>3</sup>, Perera SN<sup>4</sup>, Goonewardena CSE<sup>5</sup>

<sup>1</sup>Department of Nursing, Faculty of Humanities and Sciences, Sri Lanka Institute of Information Technology, Sri Lanka

<sup>2</sup>Department of Clinical Sciences, Faculty of Medicine, General Sir John Kotelawala Defence University, Sri Lanka

<sup>3</sup>Department of Nursing and Midwifery, Faculty of Allied Health Sciences, University of Sri Jayewardenepura, Sri Lanka

<sup>4</sup>National Cancer Control Programme, Ministry of Health, Sri Lanka

<sup>5</sup>Department of Community Medicine, Faculty of Medical Sciences, University of Sri Jayewardenepura, Sri Lanka

Corresponding Author: keenirosha@yahoo.com

#### **Overview of research or innovation:**

Pain is a feared symptom that is present in all stages of cancer and is likely to diminish the general well-being and quality of life of cancer patients. Individual experiences and responses to cancer pain are diverse and highly subjective. Self-reports of pain experience are therefore regarded as the most reliable source of information. Further, the multidimensional nature of the ‘total pain’ experienced warrants assessment using holistically based, culturally-adapted tools in the follow-up.

Due to bias in recalling past occurrences, self-reported cancer pain experiences may be inaccurate during pain clinic follow-up visits. Psychosocial and pain-related factors may cause patients to exaggerate or reconstruct their pain. Distress, pain intensity, and past pain may also affect the pain reported. Thus, keeping a pain diary daily minimizes prejudice in recalling past events. The pain diary helps the "pain team" understand how the pain experience and related features have changed in the week/s before the clinic visit and help them plan therapies to improve outcomes.

#### **Purpose/objectives of the research:**

This study developed and psychometrically validated a holistically based, patient-centered follow-up pain assessment diary for monitoring pain experience in Sinhala-speaking cancer patients in Sri Lanka.

#### **Methods**

The two-phase mixed-method study collected qualitative and quantitative data from August 2019 to April 2021. Phase I developed the pain diary and Phase II assessed its psychometric qualities.

**Phase I:** A sufficient number of items in the pain diary were generated to cover every dimension of the pain experience through qualitative patient and key informant interviews and literature-based information. The best items were selected from the pooled items using the Modified Delphi technique with the participation of a panel of subject and clinical experts. Pre-testing was done with purposively selected 15 patients with cancer pain. The patients were interviewed individually on the clarity and comprehensibility of each item.

**Phase II:** Psychometric features of the pain diary were examined and validated among patients diagnosed with different types of cancers attending the Outpatient Medical Oncology Clinic at Teaching Hospital, Ratnapura.

The study comprised Sinhala-speaking patients aged 18–65 with cancer-related pain that lasted at least a month. Patients with psychological instability, primary brain tumors, or brain metastases were excluded. The sample size was determined using the general guideline of 5–10 individuals per item.

On the recruiting day, participants were given the pain diary with instructions. The diary was to be filled up for four consecutive weeks and brought to the cancer follow-up clinic on the next visit. Interviewer-administered validated Sinhala versions of the Short Form Brief Pain Inventory, Short Form McGill Pain Questionnaire -2, and European Organization for Research and Treatment of Cancer Core Quality of Life Questionnaire-C30 were used to collect data for comparison. Construct validity was evaluated using convergent, divergent, and exploratory factor analysis (EFA). The convergent validity of subscales was assessed using the average variance extracted (AVE) ( $> 0.5$ ) Discriminant validity was examined by the heterotrait-monotrait (HTMT) criterion ( $< 0.9$ ). The reliability analysis was done by evaluating the composite reliability (CR) (0.70 - 0.95), and the internal consistency by Cronbach's alpha coefficients of  $\geq 0.70$ .

The Ethics Review Committee, Faculty of Medical Sciences, University of Sri Jayawardenepura, approved the study (ERC No: 28/19).

### **Findings:**

A total of 97 subjects were analyzed. The six key dimensions to be assessed identified; pain and related features, physical, psychological, social, spiritual, and financial. There were four factors with extracted Eigenvalue above 1. The first three factors explained the variance of 56.3% which was meaningfully interpreted as ‘influence on daily life due to pain’, ‘gastric disturbances’, and ‘pain intensity’.

AVE of the subscales, ‘Influence to daily life’, ‘Gastric disturbances’, and ‘intensity’ was 0.526, 0.562, and 0.696, respectively. The HTMT values between ‘Influence to daily life’ and ‘intensity’ was 0.691, ‘Influence to daily life’ and ‘gastric disturbances’ was 0.534 and ‘intensity’ and ‘gastric disturbances’ was 0.44. All HTMT values were lower than the threshold and confirmed the discriminant validity of subscales of the pain diary.

Scores with reference tools showed good to excellent correlation coefficients. Each subscale's Cronbach's alpha ranged from 0.75 to 0.92 and composite reliability from 0.921 to 0.826.

### **Conclusion**

The holistic aspects-based follow-up pain assessment diary for self-documentation of cancer pain is a reliable, valid, and culturally acceptable tool to assess physical, psychological, social, and spiritual well-being in the days and weeks before clinic visits among Sinhala-speaking cancer patients in Sri Lanka.

**Practical Implications – what can be learned from this project?**

The pain team doesn't need patients to "recall" past pain because the diary offers correct information. "Worst pain," "impact on quality of life," and "satisfaction with treatments" might be used to evaluate pain therapies in the preceding period.

**Novelty**

In the past, Sinhala-speaking patients in Sri Lanka hadn't had holistically based, culturally tailored follow-up tools to assess and record cancer pain. The validated tool we developed fulfills the long-felt requirement in the assessment of follow-up pain in cancer patients.

Most pain diaries focused on pain severity and were not generalizable among cancer pain trajectories. Without user input, certain tools were made (cancer patients or pain teams). Though a few instruments focus on extra dimensions of pain, notably spiritual pain, the economic burden of pain on cancer patients, etc., which are deemed essential in this group, were rarely measured. No country with a similar socioeconomic and cultural background to Sri Lanka has explored or utilized those tools.

**The benefit to society:**

Unrelieved pain and the socio-financial burden on the individual, family, and society owing to lost production and demand on public funds and unnecessary re-admissions. Further, having to experience pain on top of cancer causes an additional burden on the patient, family, and caregiver with negative implications on general well-being and quality of life. Holistically based continued self-assessment of cancer pain helps healthcare practitioners comprehend the different and ever-changing aspects of pain experience to assess the "total pain experience" and utilize suitable multi-modal therapy to enhance pain outcomes and negative impact on the patient and family and the community can be minimized.

## Story of Young Innovators in Health Sciences



### **Removing Cancer-Causing Pollutants in the Environment by Immobilizing Aromatic Hydrocarbon Degrading Phyllosphere Bacteria and Fungi: Phylloremediation Approach to Green Air**

Dharmasiri RBN<sup>1,2</sup>, Undugoda LJS<sup>1\*</sup>, Nilmini AHL<sup>3</sup>, Pathmalal MM<sup>2,4</sup>, Nugara NNRN<sup>1</sup>, Udayanga D<sup>1</sup>

<sup>1</sup>Department of Bio-systems Technology, Faculty of Technology, University of Sri Jayewardenepura, Sri Lanka.

<sup>2</sup>Faculty of Graduate studies, University of Sri Jayewardenepura, Sri Lanka.

<sup>3</sup>Department of Material and Mechanical Technology, Faculty of Technology, University of Sri Jayewardenepura, Sri Lanka

<sup>4</sup>Centre for water quality and algae research, Department of Zoology, Faculty of Applied Sciences, University of Sri Jayewardenepura, Sri Lanka

Corresponding Author: [lankaundugoda@sjp.ac.lk](mailto:lankaundugoda@sjp.ac.lk)

#### **Overview of your research or innovation**

Aromatic hydrocarbons (AH) air pollutants have been released from many anthropogenic sources into the environment. These pollutants cause many health effects due to their high carcinogenicity and genotoxicity. Most polycyclic aromatic pollutants settle over the phyllosphere through dry deposition and wet depositions. The phyllosphere provides an ideal environment for many microorganisms, some of which can degrade AHs. Scientists newly found that several AHs are cancer-causing chemicals. Air pollution is one of the leading causes of sickness and death worldwide. Annually, outdoor air pollution is attributed to an assessed 4.2 million premature deaths, and strokes, primarily due to heart disease, lung cancer, acute respiratory infections in children, and chronic obstructive pulmonary disease. Worldwide, 43% of deaths are caused by chronic obstructive pulmonary disease, 29% of deaths by ischemic heart disease and lung cancer. The research studies in Sri Lanka indicate that air contamination is a significant hazard to the country's public health. All studies, showed significant correlations among air contamination and detrimental health outcomes. Bio-filter production like bioremediation mechanisms, can be used to remove contaminants from the air, and the microbes can be effortlessly used in these mechanisms as consortiums which is more effective in degrading AH contaminants.

#### **Purpose/objectives of the research**

The present study aimed to isolate phenanthrene, anthracene, naphthalene, pyrene, xylene, and toluene like cancer causing AHs degrading bacteria and fungi from leaf samples collected from heavily polluted areas. Afterwards, immobilizing those non-inhibiting and

heat tolerant bacterial and fungal consortia into an immobilizing medium, and finally, introducing a bio-filter unit which contains replaceable live microbial consortia pellets as a bioremediation approach to the green air concept.

## Methodology

Leaf samples from five ornamental plant species (*Ixora chinensis*, *Ervatamia divaricate*, *Plumeria* sp., *Hibiscus rosa-sinensis*, and *Amaranthus cruentus*) were collected in six highly polluted areas of Colombo, Sri Lanka (Pettah, Colombo Fort, Maradana, Panchikawatta, Orugodawaththa, and sapugaskanda oil refinery sites) and Kandy. Meemure was tested as the control site. AHs degradation potential of the isolated bacteria and fungi was then assessed using a plate assay, and their degradation kinetics were evaluated using High Performance Liquid Chromatography (HPLC). The phyto-toxicity assay was conducted using Mung (*Vigna radiate*) seeds and *Artemia salina*. The viable cell counts were counted by using a hemocytometer. The produced by-products during the AH degradation pathways were identified using Gas Chromatography and Mass Spectrometer (GC-MS). Antibiotic resistance of bacteria was separately tested using 3 antibiotics (Erythromycin, Ampicillin and Streptomycin). Depolymerizing enzymatic approach of fungi during the AHs degradations was tested focusing on three enzymes (Manganese-dependent peroxidases (MnPs) lignin peroxidases (LiPs), and laccases). Bacteria and fungi were tested separately for inhibition tests, and used both bacteria, and fungi in the same medium and the inhibition was tested. Then best AH-degrading temperature-tolerant bacteria and fungi were selected. Bio-filter production was carried out by using these selected nine bacterial strains and eight fungal isolates in separate consortia. The medium was optimized by using biochar, coco peats, and tea refuse. Biofilter was innovated in lab scale and confirmed the usage with environmental pollution investigations.

## Findings

Nine bacteria and eight fungi were identified as the best temperature-tolerant AH degraders. HPLC results revealed the best degradation rates for the 9 bacteria (*Bacillus* sp. P<sub>2</sub>B-02, *B. velezensis* P<sub>2</sub>B – 04, *B. Pumilus* P<sub>2</sub>B - 05, *P. stutzeri* P<sub>8</sub>M – 17, *Bacillus* sp.1 P<sub>8</sub>M - 21, *B. megaterium* P<sub>9</sub>T - 26, *B. mycoides* P<sub>9</sub>T - 31, *Bacillus toyonensis* P<sub>13</sub>T- 69 and *Bacillus thuringiensis* P<sub>13</sub>T- 71) and 8 fungi (*Trichoderma harzianum* isolate P<sub>4</sub>M – 16, *Purpureocillium lilacinum* isolate P<sub>10</sub>T – 28, *Penicillium griseofulvum* isolate P<sub>9</sub>B – 30, *Aspergillus terreus* isolate P<sub>21</sub>B – 34, *Fusarium solani* isolate P<sub>11</sub>M-46, *Aspergillus fumigatus* isolate P<sub>19</sub>B – 56, *Aspergillus flavus* isolate P<sub>22</sub>T-82 and *Penicillium citrinum* isolate P<sub>23</sub>B-91). Toxicity assays confirmed that the produced by-products such as Phenol, 2-(phenylmethyl) (C<sub>13</sub>H<sub>12</sub>O) from phenanthrene and 9,10-Anthracenedione from anthracene were not toxic to the bacteria itself as well as the phyllosphere and they were identified and confirmed through GC-MS. The best immobilizing medium was tested and confirmed (including coco peats:tea refuse:biochar= 2:3:1). Bacteria and Fungi were immobilized into the modified bed medium in separate layers developed replaceable compressed pellets with alive microbes and produced a user-friendly, eco-friendly and affordable bio-filter unit.

## Conclusions

Urbanized areas which are polluted with aromatic hydrocarbons are rich in aromatic hydrocarbon-degrading bacterial strains, and fungal isolates and the fast aromatic hydrocarbon-degrading phyllosphere bacterial and fungal strains can be used as effective bioremediators because of their high capability to endure aromatic hydrocarbon pollutants while degrading those aromatic hydrocarbons into nontoxic forms. By isolating and

identifying the best aromatic hydrocarbon degrading phyllosphere bacterial and fungal strains inhabiting some of the most abundant ornamental plant leaf surfaces in highly polluted areas and can use them as the immobilized bacteria and fungi which have the potential to be attached into an immobilized medium and activate as an efficient bioremediators at any polluted environments where contamination is caused by numerous types of aromatic hydrocarbon.

### **Practical Implications**

Biofilters are one of the trending bioremediation techniques. It is a crucial separation method that can be applied to remove organic contaminants from the air. These selected bacteria and fungi can survive independently by consuming only these AHs as their sole energy source. So if we use these microbes in the bioremediation process, they can clean the air without interrupting other ecological cycles. Within a week, these bacteria and fungi can reduce AHs by up to 90%. This could be an outstanding scientific achievement. Introducing novel technology and innovative pollution bio-controlling unit for sustainable resource management reduces the air pollution risk in Sri Lanka.

### **Novelty**

A research team from the Faculty of Technology at the University of Sri Jayewardenepura in Sri Lanka is researching the use of biological agents to remove environmental pollutants like AHs from the air. Although the biological approach to bioremediation is currently a high priority, Sri Lankans need to be more knowledgeable about these types of contaminants with bioremediation technologies. Our experts have already started this investigation since ignoring these contaminants might become a significant issue in the future. We discovered that some bacterial and fungal species could function as biological agents that can break down AHs in the phyllosphere.

The research study used these efficient AH degraders as the very first experiment to develop a bio-filter in Sri Lanka. The bacteria used in this study were selected by evaluating them for resistance to antibiotics, heat tolerance, immobilization ability, enzymatic activity, and antimicrobial activity. This is a significant development in the bioremediation-based elimination of air pollution in Sri Lanka. This study idea could be used commercially cost- and eco-efficient. This degrading process is environmentally friendly, and the concept may also be applied to reduce air pollution. Currently, our researchers are commercializing this environmentally beneficial approach to remove pollutants like AHs from the environment. This will be a significant advance for Sri Lanka to reduce major air pollutants in an eco-friendly and cost-effective way.

We, as a Sri Lankan research team of Faculty of Technology; University of Sri Jayewardenepura is currently conducting experiments to use biological agents to remediate AHs like air contaminants from the environment. This biological approach to bioremediation is a trending topic worldwide nowadays but as Sri Lankans, our awareness about these kinds of pollutants and bioremediation methods are quite poor. Our scientists have already initiated this research mainly because neglecting these kinds of pollutants can be a huge problem in near future. We found that some genera of bacteria and fungi can act as biological agents which can degrade AHs in the phyllosphere.

### **Benefit to the society**

Researchers discovered chemical and physical ways to eliminate AHs from the environment because this issue is now considered to be challenging. But there can be a number of adverse consequences. Researchers are also investigating with bioremediation strategies to remove those cancer-causing AHs from the environment in an effort to minimize those detrimental

consequences. The introduction of biofilter units as a novel, innovative pollutant controller through the use of biotechnological approaches has become a major trend in the new science community. The main benefit of using biofilters is that they absorb contaminated air and the microbes break down those chemicals into nontoxic levels with little upfront cost and maintenance. Bioremediation is the concept of using living organisms to change harmful compounds into harmless ones.

Since this matter is considered a challenging topic at the moment, researchers found chemical and physical methods to remove AHs from the environment. But there can be several side effects. To minimize those side effects now researchers experimenting with bioremediation techniques to remove those cancer-causing AHs from the environment. Introducing the biofilter units as a novel innovative pollutant controller with the use of biotechnological approaches becomes a huge trend in the new science community and the major importance of using biofilters is, they absorb contaminated air and the microbes degrade those chemicals into nontoxic levels with low investment and operation cost. Use of alive organisms to transform toxic substances into nontoxic forms was the concept of bioremediation. This degradation mechanism is really eco-friendly and this concept is also can be used in air pollution control. For the moment our scientists are interested in using this eco-friendly concept in a commercialized way to remediate pollutants such as AHs from the environment and this will be a huge step in the scientific community in Sri Lanka.

### **Acknowledgement**

Author glad to acknowledge University of Sri Jayewardenepura, Sri Lanka for the financial assistance under the research, Grant/Award Number: ASP/01/RE/TEC/2017/72.

## **Symposium on “Sustainable development of health and wellbeing”**



**Prof. Leanne Boyd**

Adjunct Professor (Monash University & La Trobe University)  
Executive Director-Learning and Teaching  
Chief Nursing and Midwifery Officer



**Dr. Shellyza Moledina Sajwani**

MPharm, PharmD, RPh  
Co-Chair, FIP Environmental Sustainability Policy Committee (2023)  
Co-Founder/Co-Chair - Canadian Association of Pharmacy for the Environment (CAPHÉ)  
Board Member - Pharmacists Without Borders Canada (PSF Canada)



**Ms. Megan Coleman**

Compliance Manager  
Department of Microbiology & Immunology  
University of Otago

## **Contemporary challenges for the nursing and midwifery professions**

### **Prof. Leanne Boyd**

Adjunct Professor (Monash University & La Trobe University)  
Executive Director-Learning and Teaching  
Chief Nursing and Midwifery Officer



**Aim:** To identify contemporary Professional Issues for Nursing and Midwifery in Sri Lanka and globally and discuss strategic solutions.

**Background:** The Covid-19 pandemic has reinforced the essential and unique role of nurses and midwives in the care of our communities. This provides an opportunity for nursing leaders in Sri Lanka to strengthen the profession.

**Methods:** A scoping review was conducted to inform the context. Professional challenges were mapped within Sri Lanka and then compared and contrasted with global challenges for nursing and midwifery.

**Findings:** The findings indicate that the Sri Lankan health system is under considerable strain and nurses are working in challenging conditions. The profession is lacking political power to influence change. There are four major challenges that impact nursing in Sri Lanka and across the world. They are; Workforce shortages; Models of Care; Professional status and Leadership development.

**Conclusion:** Future directions to address these areas requiring development are discussed and solutions posited.

## **Sustainability environment and planetary health: Role of the pharmacists, pharmaceutical scientists and pharmacy educators**

### **Dr. Shellyza Moledina Sajwani**

MPharm, PharmD, RPh

Co-Chair, FIP Environmental Sustainability Policy Committee (2023)

Co-Founder/Co-Chair - Canadian Association of Pharmacy for the Environment (CAPHÉ)

Board Member - Pharmacists Without Borders Canada (PSF Canada)



This session will address the crucial role of healthcare workers, specifically pharmacists, in addressing climate change and its impact on public health. The session will provide an overview of climate mitigation and adaptation strategies, as well as the impact of pollution on public health. Attendees will learn about the importance of sustainable pharmacy practices, promoting the use of renewable resources, and implementing environmentally responsible policies. The session will highlight the impact of climate change on healthcare delivery, including the need for improved disaster preparedness and emergency response. The pharmacy profession has a unique opportunity to make a positive impact on climate change and public health, and the session will provide insights and best practices for healthcare workers seeking to promote sustainability and mitigate climate-related health risks. By becoming leaders in the fight against climate change, healthcare workers can improve the health of their patients and communities while protecting the environment. The session will provide valuable information for pharmacists and other healthcare workers seeking to address the critical issue of climate change.

## **Laboratory safety and compliance, with a focus on the human element**

**Ms. Megan Coleman**  
Compliance Manager  
Department of Microbiology & Immunology  
University of Otago



Laboratory safety and compliance is not the responsibility of any one individual. Everyone, from institution management, laboratory supervisors, all staff and students, must be involved in safety and compliance to ensure that the laboratory is a safe and healthy workplace. A culture of safety and compliance should be developed, and staff and students should be supported in maintaining the culture and good lab practice. This presentation touches on how we can build capacity, support staff and students, and improve our systems.

## Oral Presentations

- 1. OP 1: Cultural adaptation and validation of Sinhala version of Frail Non-Disabled Tool: a pilot study to compare with gold standard Fried phenotype**  
Silva FHDS<sup>1\*</sup>, Ramadasa GU<sup>2</sup>, Perera S<sup>1</sup>, Ganhewa G<sup>1</sup>, Perera GLSN<sup>3</sup>, Lekamwasam S<sup>4</sup>  
<sup>1</sup>Department of Medicine, Faculty of Medical Sciences, University of Sri Jayewardenepura, Sri Lanka, <sup>2</sup>Department of Medicine, Faculty of Medicine, Sabaragamuwa University of Sri Lanka, Sri Lanka, <sup>3</sup>National Cancer Control Programme, Sri Lanka, <sup>4</sup>Department of Medicine, Faculty of Medicine, University of Ruhuna, Sri Lanka.
- 2. OP 2: Awareness, attitudes, and perceived skillfulness towards telehealth and telenursing among nurses in a selected hospital, Sri Lanka**  
Dilhani PDO<sup>1\*</sup>, Ilankoon IMPS<sup>2</sup>  
<sup>1</sup>National Hospital of Sri Lanka (NHSL), Sri Lanka, <sup>2</sup>Department of Nursing and Midwifery, Faculty of Allied Health Sciences, University of Sri Jayewardenepura, Sri Lanka.
- 3. OP 3: Knowledge and attitudes on postpartum depression among family members of pregnant women attending antenatal clinics in Rathnapura and Colombo districts**  
Wanigasooriya SLDPA<sup>1\*</sup>, Mirshan S<sup>1</sup>, Ranasinghe RARC<sup>1</sup>, Gunawardana ADIN<sup>1</sup>, Wickramaarachchi KWIU<sup>1</sup>, Shiyam A<sup>2</sup>, Seneviratne Alles SMP<sup>3</sup>, Seneviwickrama KLMD<sup>2</sup>  
<sup>1</sup>Faculty of Medical Sciences, University of Sri Jayewardenepura, Sri Lanka, <sup>2</sup>Department of Community Medicine, Faculty of Medical Sciences, University of Sri Jayewardenepura, Sri Lanka, <sup>3</sup>Department of Psychiatry, Faculty of Medical Sciences, University of Sri Jayewardenepura, Sri Lanka.
- 4. OP 4: Nurses’ awareness on legal aspects related to nursing regulation and associated factors in a selected teaching hospital, Sri Lanka**  
Herath HMSN<sup>1\*</sup>, Seneviratne SMKS<sup>2</sup>  
<sup>1</sup>Colombo South Teaching Hospital, Sri Lanka, <sup>2</sup>Department of Nursing and Midwifery, Faculty of Allied Health Sciences, University of Sri Jayewardenepura, Sri Lanka.
- 5. OP 5: Learning styles and their associated factors among Medical undergraduates of 2018/2019 intake in selected Medical faculties in Sri Lanka**  
Kumarasinghe WMM<sup>1\*</sup>, Wijeratne DC<sup>1</sup>, Caldera HSD<sup>1</sup>, Silva NHK<sup>1</sup>, Ranasinghe BAHP<sup>1</sup>, Hettiaratchi UPK<sup>2</sup>, Shiyam A<sup>3</sup>, Seneviwickrama KLMD<sup>3</sup>  
<sup>1</sup>Faculty of Medical Sciences, University of Sri Jayewardenepura, Sri Lanka, <sup>2</sup>Department of Biochemistry, Faculty of Medical Sciences, University of Sri Jayewardenepura, Sri Lanka, <sup>3</sup>Department of Community Medicine, Faculty of Medical Sciences, University of Sri Jayewardenepura, Sri Lanka.
- 6. OP 6: Relationship between non-communicable diseases and musculoskeletal pain among computer-using office workers in selected Regional Secretariat Offices**  
Jinadasa PPDN<sup>1\*</sup>, Mathangasinghe Y<sup>2</sup>, Perera RS<sup>3</sup>  
<sup>1</sup>Department of Allied Health Sciences, Faculty of Medicine, University of Colombo, Sri Lanka, <sup>2</sup>Department of Anatomy Genetics and Biomedical Informatics, Faculty of Medicine, University of Colombo, Sri Lanka, <sup>3</sup>Department of Cell and Developmental Biology, Biosciences Division, University College London, United Kingdom.
- 7. OP 7: Effect of sperm parameters on success rate of Intra Uterine Insemination among couples attending a selected fertility care center in Colombo District.**  
Gunathilaka RH<sup>1</sup>, Kumara HBBH<sup>1</sup>, Akalanka HMK<sup>2\*</sup>, Rajapaksa A<sup>3</sup>

<sup>1</sup>Department of Medical Laboratory Sciences, Faculty of Allied Health Sciences, University of Sri Jayewardenepura, Sri Lanka, <sup>2</sup>Department of Basic Sciences, University of Sri Jayewardenepura, Sri Lanka, <sup>3</sup>Suvika Fertility Centre, Sri Lanka.

**8. OP 8: Maternity care providers’ perceptions on the quality of intrapartum care: An exploratory descriptive qualitative study in Teaching Hospital Peradeniya**

Weerasingha BRGTK<sup>1\*</sup>, Abeyrathne RM<sup>2</sup>, Tennakoon S<sup>3</sup>, Ratnayake RMCJ<sup>1</sup>

<sup>1</sup>Department of Obstetrics and Gynecology, Faculty of Medicine, University of Peradeniya, Sri Lanka,

<sup>2</sup>Department of Sociology, Faculty of Arts, University of Peradeniya, Sri Lanka, <sup>3</sup>Department of Community Medicine, Faculty of Medicine, University of Peradeniya, Sri Lanka.

**9. OP 9: Psychosocial experiences of nurses caring for people with COVID-19 at Mahamewnawa treatment center, Kandy**

Senavirathna SNWMWACB<sup>1</sup>, Herath HMAP<sup>2</sup>, Kularathna MDLI<sup>3</sup>, Senavirathna SDIL<sup>4</sup>, Yapa HE<sup>5\*</sup>

<sup>1</sup>Rehabilitation Hospital, Digana, Sri Lanka, <sup>2</sup>Medical Officer of Health (MOH), Nawalapitiya, <sup>3</sup>Medical Officer of Health (MOH), Kotmale, <sup>4</sup>District General Hospital, Polonnaruwa, <sup>5</sup>Department of Nursing, The Open University of Sri Lanka.

**10. OP 10: Health promoting lifestyle among patients with Non-Communicable Diseases (NCDs) attending Colombo South Teaching Hospital in Sri Lanka during the COVID-19 pandemic**

Sandamali DHD<sup>1</sup>, Rajapaksha HHN<sup>1</sup>, Madhushankha MMMM<sup>1</sup>, Surangi MAS<sup>1</sup>, Subodhani ATHM<sup>1</sup>, Ranasinghe RKKD<sup>2\*</sup>, Samarana HMVA<sup>2</sup>, Senarath NSASN<sup>1</sup>, Nisansala MSDN<sup>1</sup>

<sup>1</sup>Department of Nursing, Faculty of Health Sciences, KAATSU International University (KIU), Sri Lanka,

<sup>2</sup>Department of Medical Science in Acupuncture, Faculty of Health Sciences, KAATSU International University (KIU), Sri Lanka.

**11. OP 12: Assessment of ability of caregivers to determine liquid paracetamol doses for infants**

Samarasekara KPDN<sup>\*</sup>, Karunanayaka KDSV, Prasadi GAM

Department of Pharmacy, Faculty of Allied Health Sciences, University of Ruhuna, Sri Lanka.

**12. OP 13: Formulation of polyherbal foot care cream for cracked heels using selected medicinal plant extracts and *invitro* evaluation of antibacterial and antioxidant activities**

Wimalarathna SMMRK<sup>\*</sup>, Hettihewa SK, Dissanayake AS

Department of Pharmacy, Faculty of Allied Health Sciences, University of Ruhuna, Galle, Sri Lanka.

**13. OP 14: Comparison of medication safety practices in pharmacies of government hospitals and private sector pharmacies for the development of a medication safety practice package for pharmacists in Sri Lanka.**

Bandara GRWSK<sup>1,2\*</sup>, Samaranyake D<sup>3</sup>, Samaranyake NR<sup>4</sup>, Galappaththy P<sup>1</sup>

<sup>1</sup>Department of Pharmacology, Faculty of Medicine, University of Colombo, Sri Lanka, <sup>2</sup>Ministry of Health,

Nutrition & Indigenous Medicine, Sri Lanka, <sup>3</sup>Department of Community Medicine, Faculty of Medicine,

University of Colombo, Sri Lanka, <sup>4</sup>Department of Pharmacy and Pharmaceutical Sciences, Faculty of Allied Health Sciences, University of Sri Jayewardenepura, Sri Lanka.

**14. OP 15: Antiglycation properties of aqueous extracts from selected plant species: An *invitro* study**

Senavirathne NHMVN<sup>1\*</sup>, Perera HKI<sup>2</sup>, Mendis BEP<sup>1</sup>, Rajapakse RPNP<sup>1</sup>, Weerapperuma TMKBB<sup>2</sup>

<sup>1</sup>Department of Food Science and Technology, University of Peradeniya, Sri Lanka, <sup>2</sup>Department of Biochemistry, Faculty of Medicine, University of Peradeniya, Sri Lanka.

15. **OP 16: Suggested improvements for residential drug rehabilitation in Sri Lanka, perception of experts and professionals in the field of substance abuse treatment**  
Dharmarathna HHND<sup>1,5\*</sup>, Jayamaha AR<sup>2</sup>, Rajapakse IH<sup>3</sup>, Gunasekara C<sup>4</sup>, Fernando N<sup>4</sup>, Meegoda MKDL<sup>5</sup>  
<sup>1</sup>Faculty of Nursing, KAATSU International University (KIU), Sri Lanka, <sup>2</sup>Faculty of Graduate Studies, KAATSU International University (KIU), Sri Lanka, <sup>3</sup>Faculty of Medicine, University of Ruhuna, Sri Lanka; <sup>4</sup>Faculty of Medical Sciences, University of Sri Jayewardenepura, Sri Lanka, <sup>5</sup>Faculty of Health Sciences, University of Sri Jayewardenepura, Sri Lanka.
16. **OP 17: Perceptions of pharmacists on delivering their services to patients with non-communicable diseases during the COVID-19 pandemic; a hospital-based qualitative study in Colombo district, Sri Lanka**  
Buddhika WSU<sup>\*</sup>, Senadheera GPSG, Jayathilake MRS<sup>2</sup>, Samaranayake NR  
Department of Pharmacy and Pharmaceutical Sciences, Faculty of Allied Health Sciences, University of Sri Jayewardenepura, Sri Lanka, <sup>2</sup>Department of Nursing and Midwifery, Faculty of Allied Health Sciences, University of Sri Jayewardenepura, Sri Lanka.
17. **OP 18: Drug-related problems and use of STOPP/START criteria in prescriptions of geriatric patients attending cardiology clinic and diabetic centre in Teaching Hospital Jaffna**  
Hasna MH<sup>1</sup>, Zumra MSF<sup>1</sup>, Madhusinghe HPPS<sup>1</sup>, Thuvaragan S<sup>1\*</sup>, Sanchayan K<sup>2</sup>, Samaranayake NR<sup>3</sup>  
<sup>1</sup>Department of Pharmacy, Faculty of Allied Health Sciences, University of Jaffna, Sri Lanka, <sup>2</sup>Department of Pharmacology, Faculty of Medicine, University of Jaffna, Sri Lanka, <sup>3</sup>Department of Pharmacy and Pharmaceutical Sciences, Faculty of Allied Health Sciences, University of Sri Jayewardenepura, Sri Lanka.
18. **OP 19: Comparative physicochemical profiles of BW 312 (red rice) and BW BLB 72-1 (white rice) Sri Lankan rice starches and maize starch BP as pharmaceutical excipients**  
Kankanamge SU<sup>1\*</sup>, Jayasuriya WJABN<sup>2</sup>, Herath HMDR<sup>2</sup>, Pathirana RN<sup>1</sup>  
<sup>1</sup>Department of Pharmacy, Faculty of Allied Health Sciences, General Sir John Kotelawala Defence University, Sri Lanka, <sup>2</sup>Department of Pharmacy and Pharmaceutical Sciences, Faculty of Allied Health Sciences, University of Sri Jayewardenepura, Sri Lanka.
19. **OP 20: Studying the influence of simulated physiological conditions and physicochemical properties of amoxicillin to improve product dissolution at pH 6.8**  
Fernando WTS<sup>1\*</sup>, ThambavitaTMDD<sup>2</sup>, Mannapperuma U<sup>2</sup>, Galappatthy P<sup>2</sup>  
<sup>1</sup>Department of Chemistry, Faculty of Science, University of Colombo, Sri Lanka, <sup>2</sup>Department of Pharmacology, Faculty of Medicine, University of Colombo, Sri Lanka.
20. **OP 21: Silver nanoparticle embedded gelatin/alginate/chitosan/polyvinylpyrrolidone Electrospun scaffold for wound dressing application**  
De Silva JHSM<sup>1</sup>, De Silva KMN<sup>1</sup>, De Silva WRM<sup>1\*</sup>, Godakanda VU<sup>1</sup>  
<sup>1</sup>Centre for Advanced Materials and Devices (CAMD), Department of Chemistry, Faculty of Science, University of Colombo, Sri Lanka.
21. **OP 22: Poly(vinylpyrrolidone)/ ethyl cellulose based electrospun wound dressing material with *invitro* hemostatic, anti-inflammatory and antibacterial activity**  
Godakanda VU<sup>1</sup>, de Silva WRM<sup>1\*</sup>, Williams GR<sup>2</sup>, de Silva KMN<sup>1</sup>  
<sup>1</sup>Centre for Advanced Materials and Devices (CAMD), Department of Chemistry, University of Colombo, Sri Lanka, <sup>2</sup>UCL School of Pharmacy, University College London, 29-39 Brunswick Square, London WC1N 1AX, UK.

**22. OP 24: Molecular characterization of environmental *Leptospira* isolated from selected areas of Rathnapura district, Sri Lanka**

Wanigarathna GUS<sup>1</sup>, Herath T<sup>2</sup>, Rathnayake NS<sup>2</sup>, Bandara RMVV<sup>2</sup>, Vijeyakumaran R<sup>2</sup>, Karunadasa AKUI<sup>2</sup>, Gamage CD<sup>2\*</sup>

<sup>1</sup>Department of Medical Laboratory Science, Faculty of Allied Health Sciences, University of Peradeniya, Sri Lanka, <sup>2</sup>Department of Microbiology, Faculty of Medicine, University of Peradeniya, Sri Lanka.

**23. OP 26: COVID-19 chest computed tomography to detect and stratify severity score using computer aided detection system**

Chandrasiri NR<sup>\*</sup>, Kulatunga S

Department of Radiography/ Radiotherapy, Faculty of Allied Health Sciences, University of Peradeniya, Sri Lanka.

**24. OP 27: Development of herbal green tea products with fruit of *Annona muricata* (Katu anoda) and Invitro evaluation**

Madhushani KLG<sup>\*</sup>, Hettihewa SK

Department of Pharmacy, Faculty of Allied Health Sciences, University of Ruhuna, Sri Lanka.

**25. OP 28: Identification of biofilm forming uropathogens in patients' urinary catheters and analysis of their exopolymer matrix**

Maduwanthi TLM<sup>1</sup>, Perera GCMK<sup>1</sup>, Nissanka NMC<sup>2,5</sup>, Wijesinghe GK<sup>3</sup>, Weerasekara DD<sup>4</sup>, Weerasekera MM<sup>2</sup>, Dilhari KAA<sup>5\*</sup>

<sup>1</sup>Department of Medical Laboratory Sciences, Faculty of Allied Health Sciences, University of Sri Jayawardenepura, Sri Lanka, <sup>2</sup>Department of Microbiology, Faculty of Medical Sciences, University of Sri Jayawardenepura, Sri Lanka, <sup>3</sup>Bristol Dental School, University of Bristol, United Kingdom, <sup>4</sup>Department of surgery, Faculty of Medical Sciences, University of Sri Jayawardenepura, Sri Lanka, <sup>5</sup>Department of Basic Sciences, Faculty of Allied Health Sciences, University of Sri Jayawardenepura, Sri Lanka.

## Poster Presentations

- 1. PP 1: Perception on body-image among undergraduates in selected faculties of astate university in Sri Lanka**  
Akurugodagama MS<sup>1\*</sup>, Munasinghe HC<sup>1</sup>, Silvapulle WS<sup>1</sup>, Hansika HMS<sup>1</sup>, Siddeek NF<sup>1</sup>, Shiyam A<sup>2</sup>, Amarasinghe Waas MDI<sup>3</sup>, Seneviwickrama KLMD<sup>2</sup>  
<sup>1</sup>Faculty of Medical Sciences, University of Sri Jayewardenepura, Sri Lanka, <sup>2</sup>Department of Community Medicine, Faculty of Medical Sciences, University of Sri Jayewardenepura, Sri Lanka, <sup>3</sup>Department of Psychiatry, Faculty of Medical Sciences, University of Sri Jayewardenepura, Sri Lanka.
- 2. PP 2: Quality of life of school teachers during COVID-19 pandemic in Biyagama educational division, Gampaha District, Sri Lanka**  
Sewwandi WKJ<sup>\*</sup>, Ilankoon IMPS  
Department of Nursing and Midwifery, Faculty of Allied Health Sciences, University of Sri Jayewardenepura, Sri Lanka.
- 3. PP 4: Knowledge on transmission of COVID-19 among employees in selected garment factories in Sri Lanka**  
Tennakoon TMWV<sup>1\*</sup>, Seneviwickrama KLMD<sup>2</sup>  
<sup>1</sup>Faculty of Allied Health Sciences, University of Sri Jayewardenepura, Sri Lanka, <sup>2</sup>Faculty of Medical Sciences, University of Sri Jayewardenepura, Sri Lanka.
- 4. PP 5: Association between reproductive factors and CVD risk in non-menopausal and postmenopausal women with Type 2 Diabetes Mellitus**  
Weerawickrama PK<sup>1\*</sup>, Weerasinghe WMCP<sup>1</sup>, Fernando IKAS<sup>1</sup>, Bulugahapitiya U<sup>2</sup>, Garusinghe C<sup>3</sup>, Karunarathna AMDS<sup>1</sup>, Abeyrathne D<sup>3</sup>  
<sup>1</sup>Faculty of Allied Health Sciences, General Sir John Kotelawala Defence University, Sri Lanka, <sup>2</sup>National Hospital of Sri Lanka, <sup>3</sup>Colombo South Teaching Hospital, Sri Lanka.
- 5. PP 6: Empathy level and associated factors among medical undergraduates of University of Sri Jayewardenepura**  
Gunathunga ND<sup>1</sup>, Kuruppu KDRM<sup>1</sup>, Wijesuriya MWAHS<sup>1</sup>, Nanayakkara SK<sup>1</sup>, Irosh BU<sup>1</sup>, Edirisinghe EAST<sup>3</sup>, Shiyam A<sup>2</sup>, Seneviwickrama KLMD<sup>2</sup>  
<sup>1</sup>Faculty of Medical Sciences, University of Sri Jayewardenepura, Sri Lanka, <sup>2</sup>Department of Community Medicine, Faculty of Medical Sciences, University of Sri Jayewardenepura, Sri Lanka, <sup>3</sup>Department of Anatomy, Faculty of Medical Sciences, University of Sri Jayewardenepura, Sri Lanka.
- 6. PP 7: Satisfaction of E-learning and associated factors among nursing undergraduates during COVID-19 pandemic in selected state universities of Western Province, Sri Lanka**  
Alahakoon ANJ<sup>\*</sup>, Meegoda MKDL  
Faculty of Allied Health Sciences, University of Sri Jayewardenepura, Sri Lanka.
- 7. PP 8: Impact of emotional intelligence on caring behavior among government nursing officers in Teaching Hospital Anuradhapura**  
Dissanayake RY<sup>1</sup>, Herath HMASK<sup>2</sup>, Jayathissa, PPSK<sup>1</sup> Kethikenella KGSS<sup>1</sup>, Wijayasundara WMSK<sup>3\*</sup> Priyanthi WN<sup>4</sup>  
<sup>1</sup>Teaching Hospital, Anuradhapura, Sri Lanka, <sup>2</sup>General Hospital Ampara, Sri Lanka, <sup>3</sup>College of Nursing, Anuradhapura, Sri Lanka, <sup>4</sup>The Open University, Sri Lanka.
- 8. PP 9: Level of self-directed learning and associated factors among nursing students in three selected colleges of nursing in Sri Lanka**  
Dissanayaka HMPN<sup>1</sup>, Ekanayaka EMCK<sup>2</sup>, Kumari WPP<sup>3</sup>, Thennakoon TMLG<sup>4</sup>, Wijayasundara WMSK<sup>5\*</sup>, Samarasekara PWGDP<sup>6</sup>

<sup>1</sup>Divisional Hospital Galenbidunuwewa, Sri Lanka, <sup>2</sup>Base Hospital Kekirawa, Sri Lanka <sup>3</sup>Base Hospital Thambuththegama, Sri Lanka, <sup>4</sup>Provincial Health Training Center, Anuradhapura, <sup>5</sup>College of Nursing, Anuradhapura, Sri Lanka, <sup>6</sup>The Open University of Sri Lanka.

**9. PP 10: The effect of sleep deprivation on short-term memory of undergraduates of KIU, Sri Lanka**

Kumara KMDD<sup>1</sup>, Boralugoda SYM<sup>1</sup>, Zahir MRM<sup>1</sup>, Sara AF<sup>1</sup>, Madulakkhana DDK<sup>1</sup>, Dunukara DMJDK<sup>1\*</sup>, Priyadarshani AMB<sup>2</sup>

<sup>1</sup>Department of Biomedical Sciences, Faculty of Health Sciences, KAATSU International University (KIU), Sri Lanka, <sup>2</sup>Department of Medical Laboratory Sciences, Faculty of Allied Health Sciences, University of Sri Jayewardenepura, Sri Lanka.

**10. PP 11: Knowledge, attitudes and practices on urinary tract infections among school teachers in selected schools in Kuliyaipitiya and Giriulla, Sri Lanka**

Safwan SM<sup>1</sup>, Dias NTB<sup>2</sup>, Dilhari KAA<sup>2\*</sup>

<sup>1</sup>Department of Nursing and Midwifery, Faculty of Allied Health Sciences, University of Sri Jayewardenepura, Sri Lanka, <sup>2</sup>Department of Basic Sciences, Faculty of Allied Health Sciences, University of Sri Jayewardenepura, Sri Lanka.

**11. PP 12: Relationship between cardiopulmonary endurance and leisure time physical activity among A/L students in selected two rural schools in Batticaloa district**

Sarmi K<sup>1\*</sup>, Yashoda H<sup>2</sup>

<sup>1</sup>Faculty of Medicine, Department of Allied Health Sciences, University of Colombo, Sri Lanka, <sup>2</sup>Department of Paediatrics, Faculty of Medicine, University of Colombo, Sri Lanka.

**12. PP 13: Geriatric non-pharmacological mental healthcare practices used at Kaithady state home for elders in Sri Lanka**

Mayuri S<sup>1\*</sup>, Rajeetha M<sup>2</sup>

<sup>1</sup>Postgraduate Institute of Science, University of Peradeniya, Sri Lanka, <sup>2</sup>Government Siddha Medical College, Palayamkottai, Tirunelveli, Tamil Nadu, India.

**13. PP 14: Knowledge on hand hygiene among healthcare professionals in the Western Province of Sri Lanka**

Wijerathne AM<sup>\*</sup>, Bandara RHMHK, Maddumage SP

School of Physiotherapy, International Institute of Health Sciences, Welisara, Sri Lanka.

**14. PP 15: Assessing the perceived vulnerability of nursing officers towards tuberculosis at the National Hospital for Respiratory Diseases in Welisara, Sri Lanka**

Priyadarshani NAW<sup>1,2</sup>, Assella IL<sup>1,3</sup>, Rukmani MWADT<sup>1,2</sup>, Fernando MRC<sup>1,2</sup>, Priyashanthi JM<sup>1,4</sup>, Sandakumari HHHS<sup>1</sup>, Kanchana KTG<sup>1</sup>

<sup>1</sup>Department of Nursing, KAATSU International University (KIU), Sri Lanka, <sup>2</sup>District General Hospital Gampaha, Sri Lanka, <sup>3</sup>National Hospital for Respiratory Diseases Welisara, Sri Lanka, <sup>4</sup>North Colombo Teaching Hospital, Sri Lanka.

**15. PP 16: Nursing informatics and learning health system among nurses during COVID-19 at selected Higher Education Institute in Sri Lanka**

Harshani PK<sup>1,2</sup>, Damayanthi WRS<sup>1,3</sup>, Rathnayaka GHAN<sup>1,2</sup>, Sandakumari HHS<sup>1</sup>, Kanchana KTG<sup>1</sup>

<sup>1</sup>KAATSU International University (KIU), Sri Lanka, <sup>2</sup>National Hospital of Sri Lanka, Colombo, Sri Lanka, <sup>3</sup>Colombo South Teaching Hospital, Sri Lanka

**16. PP 17: Demographic and clinical characteristics among type 2 diabetic patients, attending the Diabetic Centre, Teaching Hospital Jaffna**

Thivya K<sup>1\*</sup>, Risla MRF<sup>1</sup>, Samiya HM<sup>1</sup>, Arasaratnam V<sup>2</sup>, Aravinthan M<sup>3</sup>

<sup>1</sup>Department of Medical Laboratory Sciences, Faculty of Allied Health Sciences, University of Jaffna, Sri Lanka, <sup>2</sup>Department of Biochemistry, Faculty of Medicine, University of Jaffna, Sri Lanka, <sup>3</sup>Diabetic Centre, Teaching Hospital, Jaffna, Sri Lanka.

17. **PP 19: Knowledge of Iron deficiency Anemia management among pregnant women in Narahenpita Area, Sri Lanka**  
Kumaran M\*, Rajapakshe NY, Saeed S, Khaleel ZA  
*School of Nursing, International Institute of Health Sciences, Welisara, Sri Lanka.*
18. **PP 20: Anemia and its etiological factors among elderly individuals attending the Family Practice Centre at the Faculty of Medical Sciences, University of Sri Jayewardenepura**  
Karunasena DKG<sup>1\*</sup>, Sewwandi KKD<sup>1</sup>, Fernandopulle B<sup>2</sup>, De Silva H<sup>3</sup>, Darshana LGT<sup>1</sup>  
<sup>1</sup>*Department of Medical Laboratory Sciences, Faculty of Allied Health Sciences, University of Sri Jayewardenepura, Sri Lanka,* <sup>2</sup>*Department of Pathology, Faculty of Medical Sciences, University of Sri Jayewardenepura, Sri Lanka,* <sup>3</sup>*Department of Family Medicine, Faculty of Medical Sciences, University of Sri Jayewardenepura, Sri Lanka.*
19. **PP 21: Knowledge and attitudes towards sexually transmitted diseases among undergraduates of KAATSU International University (KIU), Sri Lanka**  
Alwis WLM<sup>1</sup>, Minnath MFS<sup>1</sup>, Gunarathne MGPA<sup>1</sup>, Tharindu VDR<sup>1</sup>, Fernando RMS<sup>1</sup>, Fasmila MFF<sup>1</sup>, Kulathunga KMHH<sup>1\*</sup>, Sampath MKA<sup>2</sup>  
<sup>1</sup>*Department of Biomedical Science, Faculty of Health Sciences, KAATSU International University (KIU), Sri Lanka,* <sup>2</sup>*Sri Lanka Institute of Biotechnology- Colombo, Sri Lanka.*
20. **PP 22: Self-care measures on managing Coronary-Artery-Disease (CAD) and its associated sociodemographic factors among patients with CAD attending the Cardiology Unit, National Hospital Sri Lanka**  
Silva NGGH, Perera RASG, Nadeeka PW, Sadamali WAK, Nisansala MWN, Senarath NSASN\*  
*Department of Basic Science, Faculty of Nursing, KAATSU International University (KIU), Sri Lanka.*
21. **PP 23: Preference, knowledge, and attitudes towards the companionship during labour; A cross-sectional study among antenatal clinic attendees in Kandy district**  
Perera KCN\*, Weerasingha BRGTK  
*Department of Nursing, Faculty of Allied Health Sciences, University of Peradeniya, Sri Lanka.*
22. **PP 24: Facilitators and Barriers of participation for Continuing Professional Education among nurses in a selected hospital in Gampaha district, Sri Lanka.**  
Ranasinghe HRAUN, Damayanthi LC  
<sup>1</sup>*Faculty of Allied Health Sciences, University of Sri Jayewardenepura, Sri Lanka.*
23. **PP 25: Factors associated with mental health among antenatal mothers attending Castle Street Hospital for Women during the COVID– 19 Pandemic**  
Tennakoon NMDN, Ruwanthi MDA, Hunukumbura WMIM, Ariyawansa BI, Karunarathne NMRA, Ranaweera RAND\*, Nisansala MWN, Senarath NSASN  
*Department of Nursing, Faculty of Nursing, KAATSU International University (KIU), Sri Lanka.*
24. **PP 26: Knowledge and attitudes towards usage of face masks during COVID-19 pandemic among nursing students, Faculty of Allied Health Sciences, University of Peradeniya: A descriptive cross-sectional study**  
Nishshanka NMDC<sup>1\*</sup>, Kumarasiri PVR<sup>2</sup>, Weerasingha BRGTK<sup>1</sup>  
<sup>1</sup>*Department of Nursing, Faculty of Allied Health Sciences, University of Peradeniya, Sri Lanka,* <sup>2</sup>*Department of Community Medicine, Faculty of Medicine, University of Peradeniya, Sri Lanka.*
25. **PP 27: Knowledge, practices and perceived barriers regarding patient education on inhaler use among nurses working in a tertiary care hospital, Western province, Sri Lanka**  
Liyanaarachchi PLDS<sup>1\*</sup>, Abeyratne RMTB<sup>2</sup>  
<sup>1</sup>*National Hospital of Sri Lanka, Sri Lanka,* <sup>2</sup> *Department of Nursing and Midwifery, Faculty of Allied Health Sciences, University of Sri Jayewardenepura, Sri Lanka.*

26. **PP 28: Factors associated with self-care agency in patients with coronary heart disease following percutaneous coronary intervention at Teaching Hospital, Kalutara**  
Senevirathne PM<sup>1</sup>, Bennet UGNL<sup>1</sup>, Amarasinghe PDHR<sup>1</sup>, Sandamali MN<sup>1</sup>, Yapa HE<sup>2\*</sup>  
<sup>1</sup>Teaching Hospital, Kalutara, Sri Lanka, <sup>2</sup>Department of Nursing, The Open University of Sri Lanka.
27. **PP 29: *In vitro* quality and stability assessment of furosemide 40 mg tablets available in Karapitiya, Galle, Sri Lanka**  
Anuruddhika KPII<sup>\*</sup>, Jayasinghe M, Subasinghe HWAS, Wijesekara K  
Department of Pharmacy, Faculty of Allied Health Sciences, University of Ruhuna, Sri Lanka.
28. **PP 30: Repackaging Propranolol tablets in plastic bags: Stability under different storage conditions**  
Madhushika IWH<sup>\*</sup>, Jayasinghe M, Wijesekara KAKD, Subasinghe HWAS  
Department of Pharmacy, Faculty of Allied Health Sciences, University of Ruhuna, Sri Lanka.
29. **PP 31: Perception towards storage, disposal and misuse of unused and expired pharmaceuticals in households amongst the staff working at Dhakshinapaya ministry complex, Labuduwa, Galle**  
Chandrasena NKPG<sup>1</sup>, Karunanayaka KDSV<sup>1\*</sup>, Gunawardena S<sup>2</sup>  
<sup>1</sup>Department of Pharmacy, Faculty of Allied Health Sciences, University of Ruhuna, Sri Lanka, <sup>2</sup>Department of Physiology, Faculty of Medicine, University of Ruhuna, Sri Lanka.
30. **PP 32: Analysis of *in vitro* antioxidant properties of Greensynthesized Ni/reduced graphene oxide composite**  
Gamage HMGMP<sup>1</sup>, Madushani WSAT<sup>1</sup>, Pahalagedara MN<sup>2\*</sup>  
<sup>1</sup>Department of Medical Laboratory Sciences, Faculty of Allied Health Sciences, University of Sri Jayewardenepura, Sri Lanka, <sup>2</sup>Department of Basic Sciences, Faculty of Allied Health Sciences, University of Sri Jayewardenepura, Sri Lanka.
31. **PP 33: Determination of the knowledge on rational usage of oral anticoagulant among patients attending to Cardiology Clinic at Teaching Hospital Jaffna.**  
Ijasa Ibrahim<sup>1\*</sup>, Paramanathan Kalki<sup>1</sup>, Rajendran Surenthirakumaran<sup>2</sup>, Mahesan Guruparan<sup>3</sup>  
<sup>1</sup>Department of Pharmacy, Faculty of Allied Health Sciences, University Of Jaffna, Sri Lanka, <sup>2</sup>Faculty of Medicine, University Of Jaffna, Sri Lanka, <sup>3</sup>Teaching Hospital, Jaffna, Sri Lanka.
32. **PP 34: Non-steroidal anti-inflammatory drug use in elderly patients; A hospital based cross-sectional study**  
Malika WI<sup>\*</sup>, De Silva KIM, Subasinghe HWAS  
Department of Pharmacy, Faculty of Allied Health Sciences, University of Ruhuna, Sri Lanka.
33. **PP 35: Irregular medication use among geriatric patients with chronic diseases: Ahospital based cross sectional study**  
Tharangani AR<sup>\*</sup>, De Silva KIM, Subasinghe HWAS  
Department of Pharmacy, Faculty of Allied Health Sciences, University of Ruhuna, Sri Lanka.
34. **PP 36: Relationship between PT/INR and APTT in patients on warfarin: A study at a tertiary care teaching hospital.**  
Attanayake MASM<sup>1</sup>, Manathunga ID<sup>1\*</sup>, Kulathilake HWCK<sup>2</sup>  
<sup>1</sup>Department of Medical Laboratory Sciences, Faculty of Medical Sciences, University of Sri Jayewardenepura, Sri Lanka, <sup>2</sup>Department of Pathology, Faculty of Medical Sciences, University of Sri Jayewardenepura, Sri Lanka.

35. **PP 37: Formulation and *invitro* evaluation of an antibacterial cream with *Nyctanthes arbor-tristis* L. flower extract**  
Silva MAH<sup>1</sup>, Siriwardhene MA<sup>2</sup>, Karunanayaka KDSV<sup>1</sup>, Yasarathna KWGKP<sup>1\*</sup>  
<sup>1</sup>Department of Pharmacy, Faculty of Allied Health Sciences, University of Ruhuna, Sri Lanka, <sup>2</sup> Department of Pharmacy and Pharmaceutical Sciences, Faculty of Allied Health Sciences, University of Sri Jayewardenepura, Sri Lanka.
36. **PP 38: Designing and validation of patient information leaflet for pediatric amoxicillin powder for oral suspension**  
Sandesh JT<sup>\*</sup>, Dissanayake GDC, Prasadi GAM  
Department of Pharmacy, Faculty of Allied Health Sciences, University of Ruhuna, Sri Lanka.
37. **PP 39: *Invitro* evaluation of radical scavenging activity of extracts of *Pterocarpus marsupium* (Gammalu) bark**  
Nawarathna TPH<sup>\*</sup>, Hettihewa SK, Dissanayake AS  
Department of Pharmacy, Faculty of Allied Health Sciences, University of Ruhuna, Sri Lanka.
38. **PP 40: Customer satisfaction towards pharmaceutical care provided by the community pharmacies in selected MOH areas, Galle District, Sri Lanka**  
Dissanayake GDC<sup>\*</sup>, Sandesh JT, Prasadi GAM  
Department of Pharmacy, Faculty of Allied Health Sciences, University of Ruhuna, Sri Lanka.
39. **PP 41: Assessment of prices, packaging, and quality of paracetamol tablets dispensed by public and private sector pharmacies in Karapitiya**  
Pramodika MAG<sup>\*</sup>, Jayasinghe M, Subasinghe HWAS, Wijesekara K  
Department of Pharmacy, Faculty of Allied Health Sciences, University of Ruhuna, Sri Lanka.
40. **PP 42: *Invitro* antioxidant activity of leaves & unripen fruits of “Tanin and Vega F1” hybrid papaya on the basis of DPPH free radical scavenging**  
Needhiraja NP<sup>1</sup>, Krishnamoorthy T<sup>1</sup>, Jayasooriya ATR<sup>1</sup>, Srikokulan S<sup>1\*</sup>, Senthilnathanan M<sup>2</sup>  
<sup>1</sup>Department of Pharmacy, Faculty of Allied Health Sciences, University of Jaffna, <sup>2</sup>Department of Chemistry, Faculty of Science, University of Jaffna, Sri Lanka.
41. **PP 43: *Invitro* determination of alpha amylase inhibitory activity of two selected medicinal plants extracts**  
Liyanaarachchi LVV<sup>1</sup>, Rathnayake HMAL<sup>1</sup>, Wijesundara WMAGUI<sup>1</sup>, Sivasinthujah S<sup>1\*</sup>, Manoranjan T<sup>2</sup>  
<sup>1</sup>Department of Pharmacy, Faculty of Allied Health Sciences, University of Jaffna, Sri Lanka, <sup>2</sup>Department of Chemistry, Faculty of Science, University of Jaffna, Sri Lanka.
42. **PP 44: Prescribing patterns of lipid lowering drugs at Teaching hospital Karapitiya**  
Edirisinghe EAAS<sup>1\*</sup>, Pathiraja VM<sup>1</sup>, Dhanarisi J<sup>2</sup>  
<sup>1</sup>Department of pharmacy, Faculty of Allied Health Sciences, University of Ruhuna, Sri Lanka, <sup>2</sup>Local Production & Assistance Unit, Regulation and Prequalification Department, Access to Medicines and Health Products Division, World Health Organization, Geneva, Switzerland
43. **PP 45: Post-marketing quality assessment of metformin hydrochloride tablets available in Karapitiya**  
Priyanath HYS<sup>\*</sup>, Jayasinghe M, Subasinghe HWAS, Wijesekara K  
Department of pharmacy, Faculty of Allied Health Sciences, University of Ruhuna, Sri Lanka.
44. **PP 46: Association of patient specific factors on the total weekly dose of warfarin**  
Liyanaage HS<sup>1\*</sup>, De Silva KIM<sup>1</sup>, Prabodha LBL<sup>2</sup>  
<sup>1</sup>Department of Pharmacy, Faculty of Allied Health Sciences, University of Ruhuna, Sri Lanka, <sup>2</sup>Department of Anatomy, Faculty of Medicine, University of Ruhuna, Sri Lanka.

45. **PP 47: Nanoemulsions encapsulated with aqueous leaf extract of *Coccinia grandis* L. Voigt (Kovakka) as a potential nanonutraceutical agent against type 2 diabetes mellitus**  
Wickramasinghe ASD<sup>1\*</sup>, Attanayake AP<sup>2</sup>, Kalansuriya P<sup>2</sup>  
<sup>1</sup>Department of Pharmacy, Faculty of Health Sciences, The Open University of Sri Lanka, Department of Biochemistry, Faculty of Medicine, University of Ruhuna, Sri Lanka.
46. **PP 48: Knowledge on adverse drug reaction monitoring and reporting system among nursing officers: A descriptive cross-sectional study**  
Sitheja WGV<sup>1\*</sup>, Jayasinghe M<sup>2</sup>, Dissanayake AS<sup>2</sup>  
<sup>1</sup>Department of Nursing, Faculty of Allied Health Sciences, University of Ruhuna, Sri Lanka, <sup>2</sup>Department of Pharmacy, Faculty of Allied Health Sciences, University of Ruhuna, Sri Lanka
47. **PP 49: *Invitro* antimicrobial efficacy of an herbal eye wash against pathogens causing conjunctivitis**  
Ambujan B<sup>1</sup>, Damayanthi HLI<sup>1\*</sup>, Uluwaduge DI<sup>2</sup>, Peiris KPP<sup>3</sup>, Bandara EMS<sup>1</sup>  
<sup>1</sup>Department of Medical Laboratory Sciences, Faculty of Allied Health Sciences, University of Sri Jayewardenepura, Sri Lanka, <sup>2</sup>Department of Basic Sciences, Faculty of Allied Health Sciences, University of Sri Jayewardenepura, Sri Lanka, <sup>3</sup>Department of Biochemistry and Clinical Chemistry, Faculty of Medicine, University of Moratuwa, Sri Lanka, <sup>4</sup>Department of Shalya Shalakyas, Faculty of Indigenous Medicine, Gampaha Wickramarachchi University of Indigenous Medicine, Sri Lanka.
48. **PP 50: Price, availability and supplier comparison of price-controlled medicines in Sri Lanka**  
Shashiprabha NAB<sup>1\*</sup>, Jayasinghe M<sup>1</sup>, Dorabawila SSKBM<sup>2</sup>  
<sup>1</sup>Department of Pharmacy, Faculty of Allied Health Sciences, University of Ruhuna, Sri Lanka, <sup>2</sup>Department of Economics and Statistics, Faculty of Arts, University of Peradeniya, Sri Lanka.
49. **PP 51: Antibiotic resistance patterns of *Escherichia coli* in paediatric urinary tract infections**  
Wickramarathne DKN<sup>1,2</sup>, Herath HMCK<sup>1,3</sup>, Chathurika PTC<sup>4</sup>, Nissanka NMC<sup>4</sup>, Dassanayake M<sup>2</sup>, Wimalagunawardana P<sup>3</sup>, Dilhari KAA<sup>4\*</sup>  
<sup>1</sup>Department of Medical Laboratory Sciences, The Open University of Sri Lanka, Sri Lanka, <sup>2</sup>Lady Ridgeway Hospital, Sri Lanka, <sup>3</sup>District General Hospital, Polonnaruwa, Sri Lanka, <sup>4</sup>Department of Basic Sciences, Faculty of Allied Health Sciences, University of Sri Jayewardenepura, Sri Lanka.
50. **PP 54: *Invitro* carbohydrate metabolizing enzyme inhibitory potential of alginate nanoparticles encapsulated of *Catharanthus roseus* L. extracts**  
De Silva WND<sup>1\*</sup>, Attanayake AP<sup>1</sup>, Arawwawala LDAM<sup>2</sup>, Karunaratne DN<sup>3</sup>, Pamunuwa KMGK<sup>4</sup>  
<sup>1</sup>Department of Biochemistry, Faculty of Medicine, University of Ruhuna, Sri Lanka, <sup>2</sup>Industrial Technology Institute, Sri Lanka, <sup>3</sup>Department of Chemistry, Faculty of Science, University of Peradeniya, Sri Lanka, <sup>4</sup>Department of Horticulture and Landscape Gardening, Faculty of Agriculture and Plantation Management, Wayamba University of Sri Lanka, Sri Lanka.
51. **PP 55: *Invitro* antioxidant potential of *Hemidesmus indicus* (Iramusu)**  
Madhuranga HDT<sup>1\*</sup>, Gunasena GKBCM<sup>1</sup>, Dharmasena WASH<sup>1</sup>, Thambiliyagoda TGKU<sup>1</sup>, Riham MCM<sup>1</sup>, Samarakoon DNAW<sup>1</sup>, Herath HMLPB<sup>2</sup>  
<sup>1</sup>Department of Biomedical Science, Faculty of Health Science, KAATSU International University (KIU), Sri Lanka, <sup>2</sup>Department of Chemistry, Faculty of Science, University of Colombo, Sri Lanka.
52. **PP 56: Evaluation of online pharmacies operating in Sri Lanka**  
Hansanie SMN<sup>\*</sup>, Mannapperuma U  
<sup>1</sup>Department of Pharmacology, Faculty of Medicine, University of Colombo, Sri Lanka.
53. **PP 57: Determination of *invitro* antioxidant potential of *Hylocereus polyrhizus* seeds**  
Kalidha Farween MR<sup>\*</sup>, Jayani DKD, Madhuranga HDT, Samarakoon DNAW

*Department of Biomedical Sciences, Faculty of Health Sciences, KAATSU International University (KIU), Sri Lanka.*

**54. PP 58: Level of medication adherence among adult patients with Chronic Kidney Disease attending Teaching Hospital Karapitiya**

Nadeesha NVP, Prabhashini HLP, Priyadarshani SVGN, Kandambi THS, Madhumali DH, Hasanthika WWR, Nisansala MWN, Senarath NSASN

*Department of Nursing, Faculty of Nursing, KAATSU International University (KIU), Sri Lanka.*

**55. PP 59: Development, translation, and validation of a pharmacy literacy tool for English or Sinhala speaking population**

Wijesinghe DS\*, Senadheera GPSG, Samaranayake NR<sup>1</sup>

<sup>1</sup>*Department of Pharmacy and Pharmaceutical Sciences, Faculty of Allied Health Sciences, University of Sri Jayewardenepura, Sri Lanka.*

**56. PP 60: Development of indicators for medication safety during administration of medicines by healthcare professionals and patients in Sri Lanka**

Weliwatte IP<sup>1\*</sup>, Samaranayake NR<sup>2</sup>, Jayawardane P<sup>1</sup>, Galappatthy P<sup>3</sup>

<sup>1</sup>*Department of Pharmacology, Faculty of Medical Sciences, University of Sri Jayewardenepura, Sri Lanka,*

<sup>2</sup>*Department of Pharmacy and Pharmaceutical Sciences, Faculty of Allied Health Sciences, University of Sri Jayewardenepura, Sri Lanka,* <sup>3</sup>*Department of Pharmacology, Faculty of Medicine, University of Colombo, Sri Lanka.*

**57. PP 61: Evaluation of cosmetic skin cream labels available in Sri Lanka**

Jayasekara ST, Senadheera GPSG, Samaranayake NR, Nadeshkumar A\*

*Department of Pharmacy and Pharmaceutical Sciences, Faculty of Allied Health Sciences, University of Sri Jayewardenepura, Sri Lanka.*

**58. PP 62: Labeling practice and associated factors of community pharmacies at municipality areas in Jaffna and Kandy Districts**

Peiris DAA<sup>1</sup>, Madhushika WT<sup>1</sup>, Udabage UGDE<sup>1</sup>, Thuvaragan S<sup>1\*</sup>, Sanchayan K<sup>2</sup>

<sup>1</sup>*Department of Pharmacy, Faculty of Allied Health Sciences, University of Jaffna, Sri Lanka,* <sup>2</sup>*Department of Pharmacology, Faculty of Medicine, University of Jaffna, Sri Lanka.*

**59. PP 63: Formulation of nutrient supplement from selected local grain varieties and comparison of their nutritional properties**

Perera TPSS, Navaratna SB, Prashantha MAB, Godakumbura PI\*

*Department of Chemistry, Faculty of Applied sciences, University of Sri Jayewardenepura, Sri Lanka.*

**60. PP 64: Knowledge and practice regarding prevention and management of anemia and influence of socio-demographics factors among antenatal mothers in Nallur MOH division**

Ahamed MIA<sup>1\*</sup>, Surenthirakumaran R<sup>2</sup>, Thabotharan D<sup>1</sup>, Nivetha K<sup>1</sup>

<sup>1</sup>*Department of Nursing, Faculty of Allied Health Sciences, University of Jaffna, Sri Lanka,* <sup>2</sup>*Department of Community and Family Medicine, Faculty of Medicine, University of Jaffna, Sri Lanka.*

**61. PP 65: Establishment and maintenance of *Aedes aegypti* (Linnaeus) mosquito colonies for vector control studies of dengue**

Dilani PVD<sup>1</sup>, Wickramasinghe PDSU<sup>1</sup>, Hapugoda M<sup>2</sup>, Silva GN<sup>1</sup>, Hettiarachchi C<sup>1</sup>,

Dassanayake RS<sup>1</sup>, Gunawardene YINS<sup>2\*</sup>

<sup>1</sup>*Department of Chemistry, Faculty of Science, University of Colombo, Colombo, Sri Lanka,* <sup>2</sup>*Molecular Medicine Unit, Faculty of Medicine, University of Kelaniya, Ragama, Sri Lanka.*

**62. PP 66: Knowledge and its associated factors on deficiency anaemia among pregnant mothers attending antenatal clinics in selected medical officer of health areas in Colombo district**

Jayamuni NA<sup>1\*</sup>, Ranasinghe RARC<sup>1</sup>, Alahapperuma SN<sup>1</sup>, Imasha KAC<sup>1</sup>, Athukorala ACR<sup>1</sup>, Kulathilake HWCK<sup>3</sup>, Alagiyawanna AMADK<sup>2</sup>, Jayasinghe LV<sup>2</sup>, Seneviwickrama KLMD<sup>2</sup>

<sup>1</sup>Faculty of Medical Sciences, University of Sri Jayewardenepura, Sri Lanka, <sup>2</sup>Department of Community Medicine, Faculty of Medical Sciences, University of Sri Jayewardenepura, Sri Lanka, <sup>3</sup>Department of Pathology, Faculty of Medical Sciences, University of Sri Jayewardenepura, Sri Lanka.

**63. PP 67: Application of reverse transcriptase-polymerase chain reaction assay in detection of BCR-ABL1 fusion gene in suspected patients with Chronic Myelogenous Leukemia (CML)**

Herath HMNN, Basnayake BMHP, Wijeyanayake LDSR, Kugadasan M, Indrajith C, Denipitiya DTH\*

*Molecular Diagnostics Department, Lanka Hospitals Diagnostics (pvt) Ltd, Colombo 05, Sri Lanka.*

**64. PP 68: Practice of biosafety guidelines issued during the COVID-19 pandemic in histopathology laboratories of two tertiary care centres in Colombo district**

Shafra MRF<sup>1</sup>, Jayathilaka SBS<sup>1</sup>\*, Prematilleke IV<sup>2</sup>

<sup>1</sup>Department of Medical Laboratory Sciences, Faculty of Allied Health Sciences, University of Sri Jayewardenepura, Sri Lanka, <sup>2</sup>Department of Pathology, Faculty of Medical Sciences, University of Sri Jayewardenepura, Sri Lanka.

**65. PP 69: The comparison of atherogenic index of plasma (AIP), visceral adiposity index (VAI), lipid accumulation product (LAP) between normal subjects and patients with acute myocardial infarction admitted to a tertiary care hospital, Sri Lanka.**

Jayawardhana PSG<sup>1</sup>, Thathsarani SMTO<sup>1</sup>, Wijesekara GUS<sup>1</sup>\*, Bandara EMS<sup>1</sup>, Thushara Matthias<sup>2</sup>

<sup>1</sup>Department of Medical Laboratory Sciences, Faculty of Allied Health Sciences, University of Sri Jayewardenepura, Sri Lanka, <sup>2</sup>Department of Medicine, Faculty of Medical Sciences, University of Sri Jayewardenepura, Sri Lanka.

**66. PP 70: Biofilm formation and multidrug resistance of coliforms isolated from malignant patients with urinary tract infections**

Vitharana BM<sup>1</sup>, Wahalathantry DM<sup>1</sup>\*, Gunasekara TDCP<sup>2</sup>, Chathuranaga BAG<sup>1</sup>, Gunasekara SP<sup>3</sup>

<sup>1</sup>Department of Medical Laboratory Sciences, Faculty of Allied Health Sciences, University of Sri Jayewardenepura, Sri Lanka, <sup>2</sup>Department of Microbiology, Faculty of Medical Sciences, University of Sri Jayewardenepura, Sri Lanka, <sup>3</sup>Apeksha Hospital, Maharagama, Sri Lanka.

**67. PP 71: Total phenolic and total flavonoid contents in crude boiled broth of commercially available Sri Lankan rice (Oryzasativa L.) varieties**

Gunawardana JW<sup>1,3</sup>, Gunawardana SA<sup>2</sup>, Perera IC<sup>3</sup>, Wageesha NDA<sup>4</sup>, Witharana C<sup>1</sup>\*

<sup>1</sup>Department of Biochemistry & Molecular Biology, Faculty of Medicine, University of Colombo, Sri Lanka, <sup>2</sup>Department of Forensic Medicine & Toxicology, Faculty of Medicine, University of Colombo, Sri Lanka, <sup>3</sup>Department of Zoology & Environment Sciences, Faculty of Science, University of Colombo, Sri Lanka, <sup>4</sup>Department of Biochemistry, Faculty of Medicine, Sabaragamuwa University of Sri Lanka.

**68. PP 72: Preliminary study on fluoride exposure and associated renal health outcomes of rural children from CKDu endemic and non-endemic regions**

Wijesundara WMPA<sup>\*</sup>, De Silva HSRD, Bandara HMNN, Hasinthara GAS, Sandamini PMMA, Gunasekara TDKSC, De Silva PMCS

*Department of Zoology, University of Ruhuna, Sri Lanka.*

**69. PP 73: A laboratory-based study for determination of cytomegalovirus infection**

Wijeyanayake LDSR, Basnayake BMHP, Herath HMNN, Kugadasan M, Indrajith C, Denipitiya DTH\*

*Molecular Diagnostics Department, Lanka Hospitals Diagnostics (PVT) Ltd, Colombo 05, Sri Lanka.*

70. **PP 74: Detection of the effects on platelet indices of COVID-19 patients at the University hospital, General Sir John Kotelalwala Defence University**  
Kumarasinghe RDKK<sup>1\*</sup>, Ranasinghe HN<sup>1</sup>, Jayawardana KGKG<sup>1</sup>, Kottahachchi DU<sup>1</sup>, Somaratne I<sup>2</sup>  
<sup>1</sup>Department of Medical Laboratory Sciences, Faculty of Allied Health Sciences, Sir John Kotelalwala Defence University, Rathmalana, Sri Lanka, <sup>2</sup>Department of Para Clinical Sciences, Faculty of Medicine, General Sir John Kotelalwala Defence University, Rathmalana, Sri Lanka.
71. **PP 75: Study of serum creatinine and uric acid in hypertensive disorders of pregnancy**  
Fawaziya HLF<sup>1</sup>, Viranga AGS<sup>1</sup>, Shahmy S<sup>2</sup>, Jayawardane MAMM<sup>3</sup>, Withanage ND<sup>1\*</sup>  
<sup>1</sup>Department of Medical Laboratory Sciences, Faculty of Allied Health Sciences, University of Sri Jayewardenepura, Sri Lanka, <sup>2</sup>National Science and Technology Commission, Sethsiripaya, Sri Lanka, <sup>3</sup>Department of Obstetrics and Gynaecology, Faculty of Medical Sciences, University of Sri Jayewardenepura, Sri Lanka.
72. **PP 76: Determination of the bacterial growth and the contamination level in reusing household plastic containers among a group of undergraduates**  
Nusla MKF<sup>1</sup>, Wickrama Arachchi WANL<sup>1</sup>, Bandara AWMKK<sup>2\*</sup>, Nandapala JHYP<sup>1</sup>  
<sup>1</sup>Department of Biomedical Sciences, Faculty of Health Sciences, KAATSU International University (KIU), Sri Lanka, <sup>2</sup>Department of Basic Sciences, Faculty of Allied Health Sciences, General Sir John Kotelalwala Defense University, Sri Lanka.
73. **PP 77: Association between body mass index with blood pressure and body fat percentage in undergraduates of University of Sri Jayewardenepura.**  
Shamindri BHN<sup>1</sup>, Abeywickrama HN<sup>1</sup>, Perera PPR<sup>2\*</sup>  
<sup>1</sup>Department of Medical Laboratory Sciences, Faculty of Allied Health Sciences, University of Sri Jayewardenepura, Sri Lanka, <sup>2</sup>Department of Biochemistry, Faculty of Medical Sciences, University of Sri Jayewardenepura, Sri Lanka.
74. **PP 78: Consumer perception on food consumption and non-communicable diseases**  
Siriwardana EKDKC<sup>\*</sup>, Chandrasekara A  
Wayamba University of Sri Lanka.
75. **PP 79: Association between serum uric acid and microalbuminuria in type 2 diabetic patients attending diabetic centre at Teaching Hospital, Jaffna.**  
Kayathri V<sup>1</sup>, Kinthuja N<sup>1</sup>, Abirami M<sup>1</sup>, Kesavan V<sup>2</sup>, Aravindan M<sup>3</sup>, Jaikrishna B<sup>1</sup>  
<sup>1</sup>Department of Medical Laboratory Sciences, Faculty of Allied Health Sciences, University of Jaffna, Sri Lanka, <sup>2</sup>Department of Chemical Pathology, Teaching Hospital, Jaffna, Sri Lanka, <sup>3</sup>Diabetic Centre, Teaching Hospital, Jaffna, Sri Lanka.
76. **PP 80: Attitudes and perception towards body image concerns and eating practices among students at a selected educational institute, Gampaha District, Sri Lanka**  
Seneviratne DBR<sup>1\*</sup>, Kaldera HPSR<sup>2</sup>  
<sup>1</sup>School of Biomedical Sciences, International Institute of Health Sciences, Welisara, Sri Lanka, <sup>2</sup>School of Nursing, International Institute of Health Sciences, Welisara, Sri Lanka.
77. **PP 81: Clinical manifestation of COVID-19 and the association of vital body parameters with chronic diseases and vaccination among infected patients**  
Rathnakumara MPB<sup>1</sup>, Gunarathne RTM<sup>1</sup>, Dayananda RGTN<sup>1</sup>, Sasithanjali MVM<sup>1</sup>, Indrachapa DM<sup>1</sup>, Perera KSA<sup>2</sup>, Samaranada HMVA<sup>2\*</sup>, Nisansala MWN<sup>1</sup>, Senarath NSASN<sup>1</sup>  
<sup>1</sup>Department of Nursing, Faculty of Nursing, KAATSU International University (KIU), Sri Lanka, <sup>2</sup>Department of Medical Science in Acupuncture, Faculty of Health Sciences, KAATSU International University (KIU), Sri Lanka.
78. **PP 82: Explore the effect of fist clenching during blood collection in the**

**measurement of serum calcium**

Vathsala S<sup>1\*</sup>, Vibeeshan T<sup>1</sup>, Umasuthan U<sup>1</sup>, Balakittnen J<sup>1</sup>, Sivakumar H<sup>2</sup>

<sup>1</sup>Department of Medical Laboratory Sciences, Faculty of Allied Health Sciences, University of Jaffna, Sri Lanka,

<sup>2</sup>Department of Pathology, Faculty of Medicine, University of Jaffna, Sri Lanka.

**79. PP 83: An evaluation of adulteration in chili powder sold in shops in the Peliyagoda urban council area**

Pushpakumara PAYN<sup>1\*</sup>, Gunawardhana VSS<sup>1</sup>, Tharaka MGGS<sup>1</sup>, Paranawithana SND<sup>1</sup>, Rajendran MR<sup>1</sup>, Samarakoon N<sup>1</sup>, Jayawickrama DR<sup>2</sup>

<sup>1</sup>Department of Biomedical Science, Faculty of Health science, KAATSU International University (KIU), Sri Lanka,

<sup>2</sup>Department of Animal Science, Faculty of Animal Science and Export Agriculture, Uva Wellassa University of Sri Lanka, Sri Lanka.

**80. PP 84: Knowledge of street food safety among the students in a private university in Colombo, Sri Lanka**

Kodikara VS, De Silva RM, Nandapala JHYP, Ranadeva NDK

Department of Biomedical Science, Faculty of Health Sciences, KAATSU International University (KIU), Sri Lanka.

**81. PP 85: Anticandidal activity of antimicrobial peptide “Octominin” encapsulated chitosan nanoparticles**

Jayathilaka EHTT<sup>1</sup>, Nikapitiya CL<sup>1</sup>, Wang I<sup>2</sup>, De Zoysa M<sup>1\*</sup>

<sup>1</sup>College of Veterinary Medicine and Research Institute of Veterinary Medicine, Chungnam National University,

Daejeon 34134, Republic of Korea, <sup>2</sup>National Marine Biodiversity Institute of Korea (MABIK), Seochun-gun, 33662, Republic of Korea.

**82. PP 86: Immune modulatory activity of exosomes isolated from *Streptococcus parauberis* infected olive flounder (*Paralichthys olivaceus*) plasma**

Jayathilaka EHTT, De Zoysa M, Nikapitiya C<sup>\*</sup>

College of Veterinary Medicine and Research Institute of Veterinary Medicine, Chungnam National University, Daejeon 34134, Republic of Korea.

## OP 1

### **Cultural adaptation and validation of Sinhala version of Frail Non-Disabled Tool: A pilot study to compare with gold standard Fried phenotype**

Silva FHDS<sup>1</sup>, Ramadasa GU<sup>2</sup>, Perera S<sup>1</sup>, Ganhewa G<sup>1</sup>, Perera GLSN<sup>3</sup>, Lekamwasam S<sup>4</sup>

<sup>1</sup>Department of Medicine, Faculty of Medical Sciences, University of Sri Jayawardenepura, Sri Lanka, <sup>2</sup>Department of Medicine, Faculty of Medicine, Sabaragamuwa University of Sri Lanka, Sri Lanka, <sup>3</sup>National Cancer Control Programme, Sri Lanka, <sup>4</sup>Department of Medicine, Faculty of Medicine, University of Ruhuna, Sri Lanka.

**Background:** Frailty, a common geriatric syndrome of vulnerability is associated with catastrophic declines in health and function. Most problematic expression of population ageing associated with weakness, slowing, decreased energy, lower activity and when severe, unintended weight loss. Frailty is not consciously identified in clinical practice and is not widely studied in Sri Lanka. A validated tool for screening frailty in a busy clinical setting is therefore much needed.

**Objective:** To validate the Sinhala version of the Frail Non-Disabled (S-FiND) tool.

**Methods & Materials:** The FiND tool consisting of five items was translated from English to Sinhala by two translators, blinded to each other. The two translations were combined and translated back to the original language by two separate translators. After verifying the content validity, unambiguity and clarity of items in a focused group discussion, the pre-final version was piloted among 30 volunteers. The final version was administered among 30 older patient volunteers (>65yrs) from the Colombo South Teaching Hospital. Reliability and validity were evaluated.

**Results:** The mean (SD) age of subjects was 73.9 (7.76) years. The overall time taken to fill the questionnaire was 2 min. The agreement between S-FiND questionnaire and Fried phenotype had a measurement of agreement of Kappa 0.64 (p=0.001). The agreements between the individual items of S-FiND; involuntary loss of weight/ more than 4.5 kg over one year, feeling of effort/ not get going and level of physical activity, with the Fried phenotype were 0.57 (p=0.02), 0.38 (p=0.035) and 0.59 (p=0.01), respectively. The sensitivity and specificity of S-FiND compared with the Fried phenotype were 75.0% and 88.2%.

**Conclusion:** The S-FiND is a valid and well-received tool that can be used in detecting frailty of non-disabled Sinhala speaking older adults.

## OP 2

### **Awareness, attitudes, and perceived skillfulness towards telehealth and telenursing among nurses in a selected hospital, Sri Lanka**

Dilhani PDO<sup>1\*</sup>, Ilankoon IMPS<sup>2</sup>

<sup>1</sup>National Hospital of Sri Lanka (NHSL), Sri Lanka, <sup>2</sup>Department of Nursing and Midwifery, Faculty of Allied Health Sciences, University of Sri Jayewardenepura, Sri Lanka.

**Background:** Telenursing (TN) is a component of telehealth (TH) that occurs when staff nurses meet the health needs of patients using information, communication and web-based systems. Telenursing is an innovative technique which can be used to provide better patient care, especially during pandemics such as COVID-19.

**Objective:** To assess awareness, attitudes and perceived skillfulness in using TH and TN among nurses.

**Methods & Materials:** A descriptive cross-sectional study was conducted among 327 registered nurses in the National Hospital of Sri Lanka from November 2021 to March 2022. A systematic random sampling technique was used to collect data using a pre-tested self-administered questionnaire. It contains socio-demographic characteristics, perceived skillfulness, attitudes and awareness of TH and TN. Total awareness scores range from 0-17. SPSS software version 26 was used for the analysis of data using descriptive statistics, Independent Samples t-Test and One-way ANOVA tests.

**Results:** The response rate was 77.5%. The mean age of the participants was 33 years (SD±6.78 years). The majority have received training in Information Technology (IT) (75.5%). Most of them (67.3%) did not have any experience in using TH. Nearly 40% of the participants perceived that they are skilful in accessing and searching a health website (43.1%) and downloading/ uploading images (42.5%). The mean awareness score towards TH and TN was 9.88 (SD±5.31). Nearly forty per cent of the participants (41.3%) had a good level of awareness (>75%), and 29.1% of the participants had a moderate level of awareness (50-75%). The mean total attitude score towards TH and TN was 19.95 (SD±9.52). There was a significant association between attitudes towards TN and TH with educational status (p=0.03) and Bonferroni Post Hoc Test found a significant mean difference between Diploma (p=0.03) and BSc (p=0.05) education levels.

**Conclusion:** Awareness and attitudes towards TH and TN were at a satisfactory level. Training programmes are recommended to improve nurses' understanding of TH and TN. Integrating informatics and digital applications into nursing curricula would be timely.

### OP 3

## **Knowledge and attitudes on postpartum depression among family members of pregnant women attending antenatal clinics in Rathnapura and Colombo Districts**

Wanigasooriya SLDPA<sup>1\*</sup>, Mirshan S<sup>1</sup>, Ranasinghe RARC<sup>1</sup>, Gunawardana ADIN<sup>1</sup>, Wickramaarachchi KWIU<sup>1</sup>, Shiyam A<sup>2</sup>, Seneviratne Alles SMP<sup>3</sup>, Seneviwickrama KLMD<sup>2</sup>

<sup>1</sup>Faculty of Medical Sciences, University of Sri Jayewardenepura, Sri Lanka, <sup>2</sup>Department of Community Medicine, Faculty of Medical Sciences, University of Sri Jayewardenepura, Sri Lanka, <sup>3</sup>Department of Psychiatry, Faculty of Medical Sciences, University of Sri Jayewardenepura, Sri Lanka.

**Background:** Postpartum depression (PPD) is a complex mix of physical, emotional and behavioural changes that occur in postpartum mothers within the first 2-4 weeks of childbirth. It has a global prevalence of 17.22% which originates in the latter part of pregnancy. A sound knowledge on PPD among close family members is important to avoid negligence and provide the necessary care for PPD.

**Objective:** To describe knowledge and attitudes regarding PPD and its associated factors among family members of pregnant women attending antenatal clinics in selected Medical Officers of Health (MOH) areas in Rathnapura and Colombo Districts.

**Methods & Materials:** A descriptive cross-sectional study was conducted among 216 immediate family members in two antenatal clinics in Rathnapura (Rathnapura Divisional Council) and Colombo (Homagama) Districts selected through multi-stage sampling using a validated, pretested, interviewer administered questionnaire. Knowledge and attitudes were dichotomized using means of the pilot test (knowledge 67% and attitudes 65%) after converting to a percentage score. Data analysis was done using SPSS version 25 and associations were determined with Chi-square test using  $p < 0.05$  as the level of significance.

**Results:** Response rate was 97.7% ( $n=211$ ). Of the sample, 68.7% ( $n=145$ ) were males. The majority (61.6%,  $n=130$ ) had a good level of knowledge and positive attitudes 64.9% ( $n=137$ ) towards PPD. Knowledge was significantly higher among those with positive attitudes ( $p < 0.001$ ) and those who have seen a mother with PPD ( $p < 0.001$ ). Religion was also significantly associated with the knowledge ( $p=0.039$ ). Only good level of knowledge was significantly associated with positive attitudes towards PPD.

**Conclusion:** Good knowledge and positive attitudes prevailed among most of the family members regarding PPD.

#### **OP 4**

### **Nurses’ awareness on legal aspects related to nursing regulation and associated factors in a selected teaching hospital, Sri Lanka**

Herath HMSN<sup>1\*</sup>, Seneviratne SMKS<sup>2</sup>

<sup>1</sup>Colombo South Teaching Hospital, Sri Lanka, <sup>2</sup>Department of Nursing and Midwifery, Faculty of Allied Health Sciences, University of Sri Jayewardenepura, Sri Lanka.

**Background:** Regulation of health professionals is required to protect the public from the risk of harm within the provision of health care. Sri Lankan nurses in the state sector are regulated by the Sri Lanka Nursing Council (SLNC). Lack of awareness of nurses regarding legal aspects of nursing regulation was found in a previous study.

**Objective:** The study was aimed to assess nurses' awareness of legal aspects related to nursing regulation and its associated factors in a selected teaching hospital in Sri Lanka.

**Methods & Materials:** A descriptive cross-sectional study was conducted using a convenience sample of 381 nurses from Colombo South Teaching Hospital (CSTH), Sri Lanka. Ethical approval was obtained. A pre-tested, self-administered questionnaire was used to collect data from February to May 2022. Data were analysed using SPSS-version 26. The mean scores were considered as cut-off values for awareness. The level of significance was considered as  $p < 0.05$ .

**Results:** The response rate was 90.3%. Of the sample, 93.7% were females. Almost 65% had good awareness of legal aspects related to nursing regulation with a mean score ( $\pm$ SD) of (5.14 $\pm$ 2.12). Almost 80% had good awareness on the purpose of regulating, but 36% were not aware of the fact that SLNC has the responsibility in regulating their practice. Low awareness was evident regarding legal responsibilities of SLNC and its authority to enforce a code of ethics (12.6%) and its powers to recommend nursing curricula (48%). There was a statistically significant association between prior learning about legal aspects and awareness related to regulation of nursing practice ( $p < 0.001$ ).

**Conclusion:** The majority of participants had an overall awareness of legal aspects of nursing regulation. However, they were less aware on some legal aspects related to nursing regulation. The SLNC should take measures to increase nurses’ awareness on legal aspects of nursing regulation to promote quality and patient safety in delivering their services.

## OP 5

### **Learning styles and their associated factors among medical undergraduates of 2018/2019 intake in selected medical faculties in Sri Lanka**

Kumarasinghe WMM<sup>1\*</sup>, Wijeratne DC<sup>1</sup>, Caldera HSD<sup>1</sup>, Silva NHK<sup>1</sup>, Ranasinghe BAHP<sup>1</sup>, Hettiaratchi UPK<sup>2</sup>, Shiyam A<sup>3</sup>, Seneviwickrama KLMD<sup>3</sup>

<sup>1</sup>Faculty of Medical Sciences, University of Sri Jayewardenepura, Sri Lanka, <sup>2</sup>Department of Biochemistry, Faculty of Medical Sciences, University of Sri Jayewardenepura, Sri Lanka, <sup>3</sup>Department of Community Medicine, Faculty of Medical Sciences, University of Sri Jayewardenepura, Sri Lanka.

**Background:** Medical undergraduates need to be equipped with the required skills to bear their responsibilities as future doctors. Learning styles and their associated factors play a major role in this regard.

**Objective:** To describe learning styles and their associated factors among medical undergraduates of 2018/2019 intake in selected medical faculties in Sri Lanka.

**Methods & Materials:** A descriptive, cross-sectional study was conducted among 432 third year medical undergraduates selected by convenience sampling from Colombo, Sri Jayewardenepura, Rajarata and Ruhuna universities. Learning styles were assessed using the 44-item Index of Learning Styles questionnaire. Based on Felder-Silverman model, learning styles were categorized under four dimensions as active-reflective, sensing-intuitive, visual-verbal, and sequential-global. Associated factors were studied under socio-demography, time management skills (by Time Management Questionnaire), and academic performance (results of the first bar examination). Data were analyzed using SPSS software version 25. Chi - square test was used to find associations. The level of significance was considered as  $p < 0.05$ .

**Results:** The majority were females (63%). Preferred learning styles were active over reflective (53.7), sensing over intuitive (56.4%), visual over verbal (69.4%), and sequential over global (55.8%). Males preferred active (62.5%) compared to females who preferred reflective (51.5%). However, no gender differences were observed in other learning styles. Factors associated with active learning styles included Colombo faculty ( $p=0.000$ ), males ( $p=0.005$ ), part time employment ( $p=0.002$ ), greater time management skills ( $p=0.000$ ), and high academic performance ( $p=0.001$ ). Sensing learning style was associated with practicing mindfulness ( $p=0.032$ ). Colombo faculty ( $p=0.000$ ), being single ( $p=0.016$ ), having greater time management skills ( $p=0.000$ ), engaged in extra-curricular activities ( $p=0.023$ ), and higher academic performance ( $p=0.000$ ) were associated with visual learning style. Rajarata faculty ( $p=0.000$ ) and low perceived computer literacy level ( $p=0.037$ ) were associated with sequential learning style.

**Conclusion:** Visual is the most preferred learning style. Socio-demography time management skills, and academic performance were found to be significantly associated with four dimensions of learning styles.

## OP 6

### **Relationship between non-communicable diseases and musculoskeletal pain among computer-using office workers in selected regional secretariat offices**

Jinadasa PPDN<sup>1\*</sup>, Mathangasinghe Y<sup>2</sup>, Perera RS<sup>3</sup>

<sup>1</sup>Department of Allied Health Sciences, Faculty of Medicine, University of Colombo, Sri Lanka, <sup>2</sup>Department of Anatomy Genetics and Biomedical Informatics, Faculty of Medicine, University of Colombo, Sri Lanka, <sup>3</sup>Department of Cell and Developmental Biology, Biosciences Division, University College London, United Kingdom.

**Background:** Due to the rapidly increasing use of computers in occupational settings, the prevalence of musculoskeletal (MSK) pain among computer users is rising. Non-communicable diseases (NCDs) account for over 53% of the global disease burden.

**Objective:** The study aimed to explore the relationship between NCDs and MSK pain among computer-using office workers.

**Methods & Materials:** A descriptive cross-sectional study conducted using convenient sampling with 198 office workers aged 20-65 years, using computers daily in two selected Regional Secretariat Offices in Matara District. A self-administered questionnaire was used to record the site-specific MSK pain (neck, back, shoulder, elbow, wrist and hand, thigh, knee, ankle and foot) in the previous 24 hours (adapted from the Brief Pain Inventory questionnaire) and self-reported presence of NCDs (hypertension, myocardial infarction, diabetes, and hypercholesterolemia) diagnosed by a medical professional. Multivariable logistic regression was conducted to explore the relationship between NCDs and MSK pain adjusted for age and sex and sub-analysis was conducted for different types of NCDs and sites of MSK pain.

**Results:** The mean age  $\pm$ SD was  $39 \pm 7.47$  years, and 78% were females. Of the sample 68.2% had MSK pain in any site. Back pain (24.7%) was the most frequent, followed by neck pain (23.7%). The proportion of NCDs was 17.7%, and diabetes (8.1%) was the commonest. The presence of NCDs was associated with increased odds of having MSK pain in the previous 24 hours (odds ratio [OR]=2.85; 95% confidence intervals [CI]1.10-7.37). In the sub-analysis, diabetes was associated with increased odds of having neck pain in the previous 24 hours (OR=5.25; 95% CI 1.77, 15.56, p=0.003).

**Conclusion:** MSK pain was common among computer-using office workers and associated with NCDs. Having diabetes was significantly associated with the neck pain in previous 24 hours.

## **OP 7**

### **Effect of sperm parameters on success rate of Intra Uterine Insemination among couples attending a selected fertility care center in Colombo District.**

Gunathilaka RH<sup>1</sup>, Kumara HBBH<sup>1</sup>, Akalanka HMK<sup>2\*</sup>, Rajapaksa A<sup>3</sup>

<sup>1</sup>Department of Medical Laboratory Sciences, Faculty of Allied Health Sciences, University of Sri Jayewardenepura, Sri Lanka, <sup>2</sup>Department of Basic Sciences, University of Sri Jayewardenepura, Sri Lanka, <sup>3</sup>Suvika Fertility Centre, Nugegoda, Sri Lanka.

**Background:** Intra Uterine Insemination (IUI) is an assisted reproductive technology commonly used to treat subfertility. Even though subfertility is common among Sri Lankan couples, the factors that impact the success rate of IUI are not well researched and reported.

**Objective:** The purpose of the research was to study the effect of sperm parameters on the success rate of IUI among a selected group of couples seeking care at a selected fertility care center in the Colombo District

**Methods & Materials:** This cross-sectional analytical study was conducted in a selected private fertility clinic in Colombo District from May 2022 to September 2022. A total of 70 couples were selected by convenience sampling method. Sperm parameters of the male partner of consenting couples were obtained before undergoing IUI using a data collection form. The success of pregnancy was confirmed by beta Human chorionic gonadotropin (HCG) concentration 14 days post insemination. The ethical approval for the study was obtained from the Ethics Review Committee of Faculty of Medical Sciences, University of Sri Jayewardenepura (MLS/9/2022). Data were analyzed using Statistical Package for Social Sciences (SPSS) version 26 by using Chi-square statistical test.

**Results:** The mean age of women was 33.9±4.5 years and men 36.2±4.7 years. Out of the 70 couples studied, 9 couples (12.85%) were successful IUI treatment. The success rate of IUI was positively associated with the pre wash sperm count (p=0.015), percentage of normal sperm morphology (p=0.046), percentage of progressive motile sperm count (p=0.003), and post wash sperm count (p=0.006), and IUI success rate was negatively associated with the age of males (p=0.007).

**Conclusion:** The age of the male partner age was negatively associated on the success rate of IUI while positively associated with the sperm count, sperm morphology, ratio of progressive motile sperm, and post wash sperm count. The success rate of IUI decreases as the age of the male increases.

## OP 8

### **Maternity care providers’ perceptions on the quality of intrapartum care: An exploratory descriptive qualitative study in Teaching Hospital Peradeniya**

Weerasingha BRGTK<sup>1\*</sup>, Abeyrathne RM<sup>2</sup>, Tennakoon S<sup>3</sup>, Ratnayake RMCJ<sup>1</sup>

<sup>1</sup>Department of Obstetrics and Gynecology, Faculty of Medicine, University of Peradeniya, Sri Lanka, <sup>2</sup>Department of Sociology, Faculty of Arts, University of Peradeniya, Sri Lanka, <sup>3</sup>Department of Community Medicine, Faculty of Medicine, University of Peradeniya, Sri Lanka.

**Background:** Substandard quality of intrapartum care makes a substantial contribution to maternal and neonatal mortality. Therefore, improving the quality of intrapartum care is key to achieving better maternal and neonatal outcomes. Perceptions of care providers are crucial in identifying the strategies to improve the quality of intrapartum care.

**Objective:** To explore the perceptions of maternity care providers on the quality of intrapartum care.

**Methods & Materials:** This qualitative study was conducted at the delivery room of Teaching Hospital, Peradeniya, Sri Lanka. Seventeen face-to-face, in-depth interviews were conducted with purposively selected midwives, nurse-midwives, nurse managers and doctors, until data saturation point. Data were analyzed using Braun and Clarke’s thematic analysis method. Trustworthiness was maintained throughout the study.

**Results:** Data analysis identified five major themes and seventeen sub-themes; 1) Care providers’ philosophy of childbirth and childbirth care (Care providers’ perceptions of childbirth, care providers’ perceptions of women in labour, care providers’ perceptions of quality of care, respectful maternity care, woman-care provider relationship) 2) Gaps in current childbirth practices in the labour room (Labour room routines, routine intrapartum care interventions) 3) Facilitators to childbirth care (Availability of physical resources, competent care providers, prompt information sharing between care providers, adherence to available protocols/guidelines) 4) Challenges to adopt evidence-based practice (EBP) in childbirth care (Barriers related to care providers, barriers related to organizational environment, barriers related to labouring women) and 5) Moving towards EBP (Gaps in childbirth care, care providers’ intention to change, suggestions to improve childbirth care).

**Conclusion:** Several contemporary barriers have affected the quality of current childbirth care. However, the majority of care providers perceived that they provide good quality care to the laboring women irrespective of the existing gaps in the current childbirth care. An integrated quality improvement approach is needed to improve the current childbirth care in the setting.

**Acknowledgement:** University Research Grants-2019 (URG/2019/03/AHS).

## **OP 9**

### **Psychosocial experiences of nurses caring for people with COVID-19 at Mahamewnawa treatment center, Kandy**

Senavirathna SNWMWMACB<sup>1</sup>, Herath HMAP<sup>2</sup>, Kularathna MDLI<sup>3</sup>, Senavirathna SDIL<sup>4</sup>, Yapa HE<sup>5\*</sup>  
<sup>1</sup>Rehabilitation Hospital, Digana, Sri Lanka, <sup>2</sup>Medical Officer of Health (MOH), Nawalapitiya, Sri Lanka, <sup>3</sup>Medical Officer of Health (MOH), Kotmale, Sri Lanka, <sup>4</sup>District General Hospital, Polonnaruwa, Sri Lanka, <sup>5</sup>Department of Nursing, The Open University of Sri Lanka.

**Background:** COVID-19 is an ongoing worldwide pandemic that creates substantial psychological and socio-economic disruption. As frontline healthcare workers, nurses are playing a key role in caring for patients and are facing multiple serious problems in everyday living.

**Objective:** This study was aimed to explore psychosocial experiences of nurses caring for people infected with COVID-19 at Mahamewnawa intermediate treatment center, Kandy.

**Methods & Materials:** A descriptive qualitative design was employed at the Mahamewnawa treatment center, Kandy. Purposively recruited 15 nurses were invited to in-depth, face-to-face semi-structured interviews guided by a theme list. All interviews were transcribed verbatim and analysed by Hsieh & Shannon (2005) inductive content analysis approach.

**Results:** Three themes were derived. Theme 1, Changes in mental wellbeing, captured feeling overwhelmed due to working long hours with heavy workload, fear of being caring for drug addicts, and fear of contracting the infection due to prolonged patient contact and limited personal protection equipment. Theme 2, Changes in family dynamics and social life reflects feeling rejected from the family and society due to self-isolation following contracting the disease or long duty shifts, reversal of family roles leading to increased spousal responsibilities towards family, and difficulty in fulfilling children’s needs resulting in disruption to children’s education and their security. Theme 3, Dealing with new normal work life explains how nurses adapt to work in new circumstances by means of strengthening teamwork for patient care, being resilient for work stresses, perceiving internal satisfaction through delivering patient care in a pandemic situation, and receiving recognition as health heroes from the society.

**Conclusion:** This study highlights that nurses caring for patients with COVID-19 encountered many challenges psychologically and socially. Greater attention from health authorities by means of strengthening staff welfare and developing strategies to manage multiple work stresses is needed.

## **OP 10**

### **Health promoting lifestyle among patients with non-communicable diseases attending Colombo South Teaching Hospital in Sri Lanka during the COVID-19 pandemic**

Sandamali DHD<sup>1</sup>, Rajapaksha HHN<sup>1</sup>, Madhushankha MMMM<sup>1</sup>, Surangi MAS<sup>1</sup>, Subodhani ATHM<sup>1</sup>, Ranasinghe RKKD<sup>2\*</sup>, Samaranada HMVA<sup>2</sup>, Senarath NSASN<sup>1</sup>, Nisansala MSDN<sup>1</sup>

<sup>1</sup>Department of Nursing, Faculty of Health Sciences, KAATSU International University (KIU), Sri Lanka, <sup>2</sup>Department of Medical Science in Acupuncture, Faculty of Health Sciences, KAATSU International University (KIU), Sri Lanka.

**Background:** Non-communicable diseases (NCDs) have become more common worldwide, including in Sri Lanka. The high burden and susceptibility to NCDs during the COVID-19 pandemic has highlighted the importance of promoting a healthy lifestyle among people living with NCDs. Obesity, atherosclerosis and high blood pressure are just some of the chronic problems exacerbated by an unhealthy lifestyle. The pandemic has significantly impacted lifestyles, mental health and quality of life, creating an unprecedented public health crisis.

**Objective:** To assess the Health Promoting Lifestyle (HPL) among patients with NCDs attending Colombo South Teaching Hospital, Sri Lanka during the COVID-19 pandemic.

**Method & Materials:** A descriptive cross-sectional study was conducted at the Colombo South Teaching Hospital in Sri Lanka on 300 patients with common NCDs. A pre-tested interviewer-administered questionnaire was used which included the Health Promoting Life Style Profile-ii, covering health responsibility, physical activity, nutrition, spiritual growth, interpersonal relationships, and stress management. The data were analysed using SPSS version 22. Ethical approval was obtained from the Ethics Review Committees of KIU and the Colombo South Teaching Hospital.

**Results:** The proportions of diabetes, obesity, heart diseases, cancer, COPD (Chronic obstructive pulmonary disease) and asthma were 60.3%, 32%, 60.3%, 6.7%, 1.3% and 27.7% respectively. Patients with diabetes had considerably poorer scores for stress management (19±3.72), physical activity (16.91±7.8), diet (24.02±5.2), and interpersonal relationships (22.14±4.35). The mean (±SD) HPL total score was 125.9 (±24.72) suggesting moderate HPL.

**Conclusion:** NCD prevalence is consequential in Sri Lanka and should be considered as a public health concern. Despite overwhelming evidence of NCD catastrophe, Sri Lanka has insufficient systems in place to assess and prevent them. Therefore, it would soon be unable to handle the burden of NCDs unless a concerted effort is undertaken to prevent, cure, and control them. To address better lifestyle choices post-pandemic, public health initiatives are required.

## **OP 12**

### **Assessment of ability of caregivers to determine liquid paracetamol doses for infants**

Samarasekara KPDN\*, Karunanayaka KDSV, Prasadi GAM

*Department of Pharmacy, Faculty of Allied Health Sciences, University of Ruhuna, Sri Lanka.*

**Background:** Paracetamol pediatric syrup is widely used as an analgesic and antipyretic in infants commonly for post vaccination fever. Due to the wide distribution of body weight of infants among the same age range, and low body weights than mentioned as minimum weight on the paracetamol syrup package, caregivers have faced difficulties in determining the correct paracetamol syrup dose for infants.

**Objective:** To assess the caregivers' ability to determine the paracetamol syrup doses for infants up to six months, and associations between caregivers' socio-demographic factors, and dose determining factors, with accuracy of dose determining.

**Methods & Materials:** A descriptive cross-sectional study was conducted among 326 caregivers who had infants up to six months, in 12 Public Health Midwife (PHM) areas of Welipitiya Medical Officer of Health (MOH) area using a purposive sampling method. Data were collected using an interviewer administered questionnaire, designed according to prior literature, and subjected to face validation and pre-testing. Ethical approval was obtained from the Ethics Review Committee of Faculty of Allied Health Sciences, University of Ruhuna. Descriptive and inferential statistics including Chi-square test, Kruskal-Wallis test, and Spearman correlation test, were performed by using SPSS version 23 and statistical significance was set at  $p < 0.05$ .

**Results:** There were 74.8% of caregivers who had administered paracetamol syrup for their infants and among them most caregivers frequently made dose determining errors including 73.8% subtherapeutic errors. Only 18.9% caregivers determined paracetamol doses correctly. There were no significant associations among caregivers' socio-demographic factors, education level ( $p=0.496$ ), age ( $p=0.061$ ), number of children ( $p=0.189$ ), and dose determining factors including method of dose determining ( $p=0.333$ ), and dose determining parameters ( $p=0.598$ ), with the accuracy of dose determining.

**Conclusion:** Caregivers made errors when determining paracetamol doses and they were predominantly subtherapeutic errors. The importance of a clear, concise caregiver information leaflet, healthcare professionals' guidance to minimize dosing errors, and re-introducing the paracetamol infant drop formulation with proper counselling of healthcare staff is recommended.

## OP 13

### **Formulation of polyherbal foot care cream for cracked heels using selected medicinal plant extracts and *in vitro* evaluation of antibacterial and antioxidant activities**

Wimalarathna SMMRK\*, Hettihewa SK, Dissanayake AS

Department of Pharmacy, Faculty of Allied Health Sciences, University of Ruhuna, Sri Lanka.

**Background:** Cracked heels are a common skin condition of the feet. *Mimosa pudica*, *Azadirachta indica*, and *Aloe barbadensis* are valuable medicinal plants that have been valued in ayurvedic medicine, especially in foot conditions.

**Objective:** To formulate an herbal foot cream for cracked heels using aqueous ethanol extracts of *M. pudica*, *A. indica* and *Aloe barbadensis* with potential anti-oxidant and anti-bacterial activities and evaluate those activities *in-vitro*.

**Methods & Materials:** The crude extracts were separately obtained by steeping the powdered dry leaves of *M. pudica* and *A. indica*, and gel of the *Aloe barbadensis* in 70% ethanol overnight in darkness. Creams were formulated as oil in water emulsions by dissolving the oil-soluble components in the oil phase and the water-soluble components in the aqueous phase and heating to 75°C separately. Following heating, the aqueous phase was added to the oil phase. When the temperature dropped to 45-50°C the freeze-dried powder of the extracts was incorporated in different proportions. Creams were evaluated for *in-vitro* anti-bacterial, anti-oxidant activities and the physical parameters for 30 days.

**Results:** The creams were semi-solid, light brown color with homogenous nature and pleasant odor. The antioxidant activity of creams showed a concentration-dependent response and all formulations showed significant anti-bacterial effects against both gram-positive and gram-negative bacteria ( $p < 0.001$ ). The highest antioxidant activity was 20.13 mmol Trolox/100g DW. The highest mean diameter of zones of inhibition against *E. coli* was 12.10 mm and against *S. aureus* was 16.25 mm. The physical parameters of the creams showed that there were no significant variations during 30 days.

**Conclusion:** The combination of *M. pudica*, *A. indica*, and *Aloe barbadensis* leaf extracts can be effectively used to treat skin conditions such as foot cracks. It could be useful when formulating cosmaceuticals for treating foot cracks. After the investigation of anti-inflammatory activities and conducting *in-vivo* clinical studies, this product can be evaluated for the commercialization.

## OP 14

### **Comparison of medication safety practices in pharmacies of government hospitals and private sector pharmacies for the development of a medication safety practice package for pharmacists in Sri Lanka.**

Bandara GRWSK<sup>1,2\*</sup>, Samaranayake D<sup>3</sup>, Samaranayake NR<sup>4</sup>, Galappaththy P<sup>1</sup>

<sup>1</sup>Department of Pharmacology, Faculty of Medicine, University of Colombo, Sri Lanka, <sup>2</sup>Ministry of Health, Nutrition & Indigenous Medicine, Sri Lanka, <sup>3</sup>Department of Community Medicine, Faculty of Medicine, University of Colombo, Sri Lanka, <sup>4</sup>Department of Pharmacy and Pharmaceutical Sciences, Faculty of Allied Health Sciences, University of Sri Jayewardenepura, Sri Lanka.

**Background:** Pharmacists play an important role in ensuring medication safety (MS).

**Objective:** To assess and compare MS practices adopted by pharmacists.

**Methods & Materials:** An observational cross sectional study was done among all pharmacists attached to two hospital pharmacies (HPs), HP1 (n=100), HP2 (n=55), and two pharmacists from each 80 private pharmacies (PPs), (n=160) around HPs using an interviewer-administered questionnaire. Implementations of predetermined MS checklist based on the key elements of Institute of safe medication practices (ISMP) for pharmacists were assessed. Practices in HPs and PPs were compared using Chi square test. Significance level was set at  $p < 0.05$ .

**Results:** Pharmacists identified 160 Look Alike Sound Alike (LASA) medicine combinations, 163 High Alert Medicines (HAM), and 60 error-prone abbreviations (EPA). Significant differences were found in practices preventing LASA confusions (HP 78.4% vs. PP 0%;  $p < 0.001$ ), reviewing prescriptions for five rights (HP 86.7% vs. PP 18.7%;  $p < 0.001$ ), and reviewing prescriptions for appropriateness of the medicines (HP 77.2% vs. PP 0%;  $p < 0.001$ ). In PPs, 90% of pharmacists did not review prescriptions for potential drug interactions while 69.2% HPs implemented ( $p < 0.001$ ). Significant differences were found in reviewing prescriptions for, duplications (HP 53.8 % vs. PP 0%;  $p < 0.001$ ), polypharmacy (HP 5.6% vs. PP 0%;  $p < 0.001$ ), use of EPAs (HP 74.2% vs. PP 0%;  $p < 0.001$ ), and in obtaining a medication history on other prescription medications from patients (HP 35.3 % vs. PP 3.1%;  $p < 0.001$ ). No HP or PP had a HAM list or LASA medicines list or used clear labeling to identify them. HAMs were stored separately, (HP 56.2% vs. PP 18.7%;  $p < 0.001$ ). Mean scores on knowledge about HAM were HP 16.53 and PP 9.56 ( $p < 0.001$ ). In HP, 12.5% of pharmacists scored 20 out of 20 on knowledge about HAM while 0% of pharmacists in PP scored full marks ( $p < 0.001$ ).

**Conclusion:** MS practices were very poorly adhered in PP compared to GP with some key practices non-existent in PP. MS practices adopted by pharmacists in both sectors need improvement. There were no protocols to handle HAMs. Development of a MS practice package for pharmacists with protocols to handle HAMs, LASA medicines, storage of medicines, and preventing errors are key essential areas.

## OP 15

### Antiglycation properties of aqueous extracts from selected plant species: An *in vitro* study

Senevirathne NHMVN<sup>1\*</sup>, Perera HKI<sup>2</sup>, Mendis BEP<sup>1</sup>, Rajapakse RPNP<sup>1</sup>, Weerapperuma TMKBB<sup>2</sup>

<sup>1</sup>Department of Food Science and Technology, University of Peradeniya, Sri Lanka, <sup>2</sup>Department of Biochemistry, Faculty of Medicine, University of Peradeniya, Sri Lanka.

**Background:** Non-enzymatic glycation generates advanced glycation end-products leading to structural and functional changes in biomolecules. Speed of glycation is accelerated in chronic hyperglycaemia as seen in diabetes mellitus. Glycation is implicated in the pathogenesis of numerous diseases including chronic diabetic complications.

**Objective:** The objective of this study was to assess antiglycation effects of five species of spices.

**Methods & Materials:** Aqueous extracts were prepared using lemongrass (*Cymbopogon citratus*) whole plant, turmeric (*Curcuma longa*) rhizome, Ceylon cinnamon (*Cinnamomum zeylanicum*) bark, and ginger (*Zingiber officinale*) rhizome and the extracts were freeze dried. Piperine 95, a pure compound from *Piper nigrum* was also included in this study. Extracts and the pure compound were re-dissolved in distilled water to obtain the test samples in a concentration series of 0.0125 to 4 mg/ml in incubation mixtures. Chicken egg lysozyme was incubated with fructose in phosphate buffer (pH 7.4) at 37 °C for 30 days in the presence and absence (negative control) of plant extracts. Aminoguanidine was used as a standard glycation inhibitor. Aliquots of samples were collected on day 7 and 21 of incubation and analyzed using sodium dodecyl-sulfate polyacrylamide gel electrophoresis (SDS-PAGE) to identify the inhibitory effect of plant extracts against glycation induced cross-linking of proteins.

**Results:** *C. zeylanicum* showed complete inhibition of lysozyme cross-linking at a concentration of 0.1 mg/ml on day 7 demonstrating the highest antiglycation activity. *C. citratus* showed similar inhibition at 0.5 mg/ml. On day 21 both *C. citratus* and *C. zeylanicum* showed complete inhibition of cross-linking at 0.5 mg/ml. On both days *C. longa* and *Z. officinale* indicated a much lower antiglycation activity. Piperine 95 was separated from the aqueous reaction mixture and did not produce any antiglycation effect.

**Conclusion:** In conclusion, among the studied aqueous plant extracts, *C. zeylanicum* and *C. citratus* demonstrated the highest *in vitro* antiglycation activity.

## OP 16

### **Suggested improvements for residential drug rehabilitation in Sri Lanka, perception of experts and professionals in the field of substance abuse treatment**

**Dharmarathna HHND<sup>1,5\*</sup>, Jayamaha AR<sup>2</sup>, Rajapakse IH<sup>3</sup>, Gunasekara C<sup>4</sup>, Fernando N<sup>4</sup>, Meegoda MKDL<sup>5</sup>**

<sup>1</sup>Faculty of Nursing, KAATSU International University (KIU), Sri Lanka, <sup>2</sup>Faculty of Graduate Studies, KAATSU International University (KIU), Sri Lanka, <sup>3</sup>Faculty of Medicine, University of Ruhuna, Sri Lanka, <sup>4</sup>Faculty of Medical Sciences, University of Sri Jayewardenepura, Sri Lanka, <sup>5</sup>Faculty of Health Sciences, University of Sri Jayewardenepura, Sri Lanka.

**Background:** Substance use disorder (SUD) is a chronic relapsing disease that affects the brain and behaviors of the person leading to a problematic pattern of substance use. Even though various pathways to addiction recovery have been identified, understanding of essential components of residential drug rehabilitation (RDR) remains limited.

**Objective:** The study aimed to explore the perception of experts and professionals in the field of substance abuse treatment, in order to ameliorate the current residential drug rehabilitation in Sri Lanka.

**Methods & Materials:** A descriptive qualitative study was conducted among purposively selected twenty-four experts and professionals in the field of substance abuse treatment at their respective centers. In-depth interviews were conducted with a semi-structured interviewer guide until data saturation was reached. The interviews were audio-taped, transcribed verbatim, and thematically analyzed. Trustworthiness was maintained throughout the study. Ethical approval was obtained from the Ethics Review Committee of the Faculty of Medical Sciences, the University of Sri Jayewardenepura.

**Results:** Findings are described under four themes which uttered essential improvements required in RDR for individuals with SUD: (1) client-centered care (2) provision of ample resources (3) need a continuous and comprehensive evaluation and (4) strengthening the aftercare and social reintegration. There are multiple deficits in personalized care and the resources required in the existing RDR. The majority of the participants highlighted having good quality aftercare is vital in the rehabilitation process to prevent relapses and there are gaps in the aftercare process in the current RDR in Sri Lanka.

**Conclusion:** Necessity of individualized treatment plans and aftercare should be strengthened for sustained recovery of the individuals with SUD who enrolled in the RDR. Families and society at large should evolve toward accepting persons in addiction recovery.

**Acknowledgment:** Accelerating Higher Education Expansion and Development (AHEAD) Operation of the Ministry of Higher Education and the World Bank for funding the study.

## OP 17

### **Perceptions of pharmacists on delivering their services to patients with non-communicable diseases during the COVID-19 pandemic; A hospital-based qualitative study in Colombo District, Sri Lanka**

Buddhika WSU<sup>1\*</sup>, Senadheera GPSG<sup>1</sup>, Jayathilake MRS<sup>2</sup>, Samaranayake NR<sup>1</sup>

<sup>1</sup>Department of Pharmacy and Pharmaceutical Sciences, Faculty of Allied Health Sciences, University of Sri Jayewardenepura, Sri Lanka, <sup>2</sup>Department of Nursing and Midwifery, Faculty of Allied Health Sciences, University of Sri Jayewardenepura, Sri Lanka.

**Background:** The COVID-19 pandemic caused a huge impact on healthcare systems worldwide. Pharmacists had various positive and negative experiences due to COVID-19 when providing their services to non-COVID patients, especially for patients with non-communicable diseases.

**Objective:** To explore the perceptions of hospital pharmacists on delivering their services to outpatients in the Colombo District of Sri Lanka during the COVID-19 pandemic.

**Methods & Materials:** An exploratory qualitative study was carried out with purposively selected six pharmacists at three state hospitals in Colombo District, Sri Lanka, who were working during the COVID-19 pandemic. Data were collected through in-depth interviews using a semi-structured interview guide during the March-June of 2022. The in-depth interviews were conducted through Zoom or WhatsApp calls and they were recorded, transcribed verbatim, and analyzed using thematic analysis (Braun and Clarke method).

**Results:** Five themes emerged from the data (1) Structure of the pharmacy (2) Personal experience of pharmacists during the COVID-19 pandemic (3) Patient medication care management (4) Stock management, and (5) Change in workload during COVID-19. Lack of space inside the pharmacy, distributing medicines to patients, providing patient counseling, high workload, medicines stock changes, and unprotected behavior of patients were the main challenges faced by pharmacists. The adaptations were a modification of the pharmacy structure and improved safety and hygienic precautions of staff. Pharmacists collaborating with non-health care service providers such as post offices and police to deliver medicines, and participation in mobile clinics were found to be opportunities gained by pharmacists.

**Conclusion:** Pharmacists conveyed a wide range of perceptions when delivering their services to patients with non-communicable diseases during the COVID-19 pandemic. These findings may help to improve ongoing pharmacy services and to adapt to any similar disruptions in the future.

## OP 18

### **Drug-related problems and use of STOPP/START criteria in prescriptions of geriatric patients attending cardiology clinic and diabetic centre in Teaching Hospital Jaffna**

Hasna MH<sup>1</sup>, Zumra MSF<sup>1</sup>, Madhusinghe HPPS<sup>1</sup>, Thuvaragan S<sup>1\*</sup>, Sanchayan K<sup>2</sup>, Samaranayake NR<sup>3</sup>

<sup>1</sup>Department of Pharmacy, Faculty of Allied Health Sciences, University of Jaffna, Sri Lanka, <sup>2</sup>Department of Pharmacology, Faculty of Medicine, University of Jaffna, Sri Lanka, <sup>3</sup>Department of Pharmacy and Pharmaceutical Sciences, Faculty of Allied Health Sciences, University of Sri Jayewardenepura, Sri Lanka.

**Background:** Monitoring of prescriptions ensures rationale use of medicine and thus it reduce the duration of hospital stay, morbidity, and mortality among the elderly.

**Objective:** This study determined the prevalence of potentially inappropriate prescribing in geriatric patients by using STOPP/START criteria, the prevalence of possible drug-related problems (prescribing and drug selection related) in patient’s medication records, and factors associated with drug-related problems.

**Methods & Materials:** This cross-sectional study was conducted in the cardiology clinic and diabetic centre, Teaching hospital, Jaffna among 400 patients who were selected by stratified random sampling technique. The prevalence of potentially inappropriate medications (PIMs) and potential prescription omissions (PPOs) using modified STOPP/START criteria for Sri Lanka, and prevalence of drug-related problems (DRPs) using prescribing and drug selection section of Pharmaceutical Care Network Europe (PCNE) classification V9.1 were assessed from patients records. The Chi-square test was used to compare the factors such as age, gender, polypharmacy and multiple comorbidities with DRPs. P value < 0.05 was considered significant.

**Results:** Potentially inappropriate medicines (PIMs) and potential prescription omissions (PPOs) were 66 (16.50%) and 140 (35.0%) respectively among 400 current medication lists of the patients. Thus, a total of 206 (51.50%) potentially inappropriate prescribing (PIPs) were identified. A total of 564 drug-related problems were identified and 316 (79.0%) prescriptions had at least one DRP. The mean DRP per prescription was  $1.79 \pm 0.845$ . Polypharmacy ( $p < 0.001$ ) and gender ( $p = 0.001$ ) were significantly associated with prescribing and drug selection section of drug-related problems.

**Conclusion:** PIMs, PPOs and drug-related problems were found among geriatric patients attending to Teaching Hospital Jaffna. Polypharmacy, gender and non-communicable diseases like type-2 diabetes mellitus and ischemic heart disease showed significant associations with drug-related problems. Monitoring of drugs at prescribing and dispensing level could ensure rationale use of medicines.

## OP 19

### **Comparative physicochemical profiles of BW 312 (red rice) and BW BLB 72-1 (white rice) Sri Lankan rice starches and maize starch BP as pharmaceutical excipients**

Kankanamge SU<sup>1</sup>\*, Jayasuriya WJABN<sup>2</sup>, Herath HMDR<sup>2</sup>, Pathirana RN<sup>1</sup>

<sup>1</sup>Department of Pharmacy, Faculty of Allied Health Sciences, General Sir John Kotelawala Defence University, Sri Lanka, <sup>2</sup>Department of Pharmacy and Pharmaceutical Sciences, Faculty of Allied Health Sciences, University of Sri Jayewardenepura, Sri Lanka.

**Background:** Starch is one of the main excipients used in pharmaceutical manufacturing. The characteristic profiles of rice varieties are different from each other due to many attributes.

**Objective:** This study aimed to compare the physicochemical profiles of starches from two different Sri Lankan rice varieties with Maize starch BP (MS).

**Methods & Materials:** Starches of BW 312 and BW BLB 72-1 were extracted by mixing powdered rice with distilled water (1:2 w/v) and filtering it with flannelette. After 48 hours, the supernatant was removed and the starch precipitate was dried at 40°C. The physicochemical parameters such as pH, particle size, bulk density, tapped and true densities, Hausner's ratio, Carr's index, angle of repose, hydration capacity, moisture sorption capacity, clarity, turbidity, and infrared spectra of two rice starches and industrially used MS were evaluated. Considering the significance level of 0.05, an independent t-test was done to analyze the data.

**Results:** The mean particle diameter ( $\mu\text{m}$ ) of BW 312, BW BLB 72-1, and MS starches is  $5.06 \pm 0.26$ ,  $5.44 \pm 0.19$ , and  $6.34 \pm 0.08$  respectively. Rice starches showed good flow properties while MS had poor flow. Both rice starches provided IR spectra similar to MS with prominent peaks at about  $3350\text{--}3500\text{ cm}^{-1}$  and  $900\text{--}1000\text{ cm}^{-1}$  representing hydroxyl groups and glycosidic linkages respectively. With respect to MS, BW BLB 72-1 starch reported a significant difference in pH ( $p=0.000$ ), particle size ( $p=0.009$ ), bulk density ( $p=0.000$ ), tapped ( $p=0.014$ ) and true ( $p=0.006$ ) densities, Hausner's ratio ( $p=0.005$ ), Carr's index ( $p=0.000$ ), angle of repose ( $p=0.005$ ), hydration capacity ( $p=0.001$ ), moisture sorption capacity ( $p=0.000$ ), clarity ( $p=0.006$ ), and turbidity ( $p=0.018$ ). BW 312 starch also reported a significant difference with MS in pH ( $p=0.000$ ), particle size ( $p=0.010$ ), bulk density ( $p=0.000$ ), tapped density ( $p=0.002$ ), Hausner's ratio ( $p=0.007$ ), Carr's index ( $p=0.000$ ), angle of repose ( $p=0.006$ ), hydration capacity ( $p=0.003$ ), moisture sorption capacity ( $p=0.000$ ), clarity ( $p=0.000$ ), and turbidity ( $p=0.000$ ) except for true density ( $p=0.318$ ).

**Conclusion:** Most of the parameters of both rice starches are not well compared with MS. However, both rice starches reported certain favorable characteristics as excipients. Therefore, modification to these starches would enhance their properties in order to serve as an alternative to Maize starch BP.

## OP 20

### Studying the influence of simulated physiological conditions and physicochemical properties of amoxicillin to improve product dissolution at pH 6.8

Fernando WTS<sup>1</sup>, Thambavita TMDD<sup>2</sup>, Mannapperuma U<sup>2</sup>, Galappatthy P<sup>2</sup>

<sup>1</sup>Department of Chemistry, Faculty of Science, University of Colombo, Sri Lanka, <sup>2</sup>Department of Pharmacology, Faculty of Medicine, University of Colombo, Sri Lanka.

**Background:** The Biopharmaceutics Classification System (BCS)-based biowaiver enables waiving *in vivo* Bioequivalence (BE) studies to *in vitro* dissolution tests during generic drug registration. Although solid oral amoxicillin products, containing 250 mg up to 875 mg, are eligible for BCS-based biowaivers, most products have failed to meet *in vitro* biowaiver dissolution criteria in pH 6.8.

**Objective:** The study aimed to improve BCS-based *in vitro* dissolution conditions for solid oral amoxicillin products in pH 6.8.

**Methods & Materials:** A locally manufactured generic, an imported generic and the innovator product of amoxicillin 500 mg capsules were selected for the study and tested for their pharmacopoeial quality. A high-performance liquid chromatography-based analytical method to detect dissolved amoxicillin concentrations was validated for linearity, accuracy, and precision. As the duodenal and jejunal pH at fasted state vary from 5.6-7.8, test media were prepared at pH 6.5 and pH 7.0 in addition to pH 6.8. *In vitro* dissolution studies using pharmacopoeial buffers having pH 6.8 and pH 7.0, bio-relevant media with pH 6.5 and 6.8 were conducted according to the World Health Organization’s biowaiver guidelines.

**Result:** The imported generic product met the biowaiver criteria in pH 6.8 buffer. The dissolution rate declined in the bio-relevant media in pH 6.5, possibly due to increased lipophilicity of the media. Both the test products and the innovator showed very rapid dissolution at pH 7.0 buffer proving the *in vitro* equivalence. In pH 6.8 bio-relevant media, dissolution results showed fluctuations, suggesting the need for further studies.

**Conclusion:** Overall, conducting *in vitro* dissolution studies in pH 7.0 showed improved results compared to pH 6.8, which is the recommended representative jejunal pH in the guideline. This study emphasizes the need to assess the drug's physicochemical properties and gastrointestinal conditions more closely when implementing BCS-based *in vitro* dissolution studies to waive *in vivo* BE studies.

OP 21

## Silver nanoparticle embedded gelatin/alginate/chitosan/polyvinylpyrrolidone electrospun scaffold for wound dressing application

De Silva JHSM, De Silva KMN<sup>1</sup>, De Silva WRM\*, Godakanda VU

Centre for Advanced Materials and Devices (CAMD), Department of Chemistry, Faculty of Science, University of Colombo (UOC), Sri Lanka.

**Background:** Wound management is challenging and expensive and most of the available wound dressings are not effective and present many limitations. Nano-scaled wound scaffolds have gained attention due to their unique properties applicable to wound management. Among the numerous technologies used to fabricate fiber nanostructures, electrospinning presides as a cost-effective, simple yet versatile method. Nano fibrous materials are attractive candidates to impregnate with metal-based nanoparticles to augment the therapeutic outcome of wound management.

**Objective:** The study aimed to develop an advanced, low-cost, antibacterial electrospun biopolymer scaffold for wound management.

**Methods & Materials:** Silver Nano Particles (AgNPs) were embedded in a polymer blend of 40% gelatin, 3% alginate, 3% chitosan, and 9% polyvinylpyrrolidone mixed with 9:1:1:1 volume ratio, using an electrospinning technique. A mixture of chitosan, AgNO<sub>3</sub> and NaOH was stirred at 90 °C for 10 hrs and AgNPs were synthesized using chitosan as a reducing and stabilizing agent. The biopolymer scaffold without AgNPs and scaffold with AgNPs were successfully electrospun at optimized voltage differences of 15.1 kV and 13.6 kV, respectively. Antibacterial assays were conducted using the disk diffusion method. For this study, ciprofloxacin was used as the positive control.

**Results:** Synthesized AgNPs were characterized using UV/Vis and Fourier-Transform InfraRed spectroscopy (FTIR). Both scaffolds were characterized using FTIR and Scanning Electron Microscopy (SEM). According to the SEM analysis, the electrospun scaffold consists of nano-scaled fibers with a diameter range between 42 nm – 81 nm. AgNPs embedded scaffold showed an 8±1 mm inhibition zone against *Staphylococcus aureus* while the biopolymer scaffold without AgNPs did not show any inhibition zone. AgNPs embedded scaffold showed an 8±1 mm inhibition zone against *Escherichia coli* while the biopolymer scaffold without AgNPs did not show any inhibition zone.

**Conclusion:** Electrospun AgNPs embedded scaffold shows good antibacterial properties against *Escherichia coli* and *Staphylococcus aureus*. This scaffold can also be regarded as a low-cost material because the components required to construct it are inexpensive, the solvents are all water-based, and the construction process is simple yet cost-effective.

## OP 22

### **Poly(vinylpyrrolidone)/ ethyl cellulose based electrospun wound dressing material with *invitro* hemostatic, anti-inflammatory and antibacterial activity**

Godakanda VU<sup>1</sup>, de Silva WRM<sup>1\*</sup>, Williams GR<sup>2</sup>, de Silva KMN<sup>1</sup>

<sup>1</sup>Centre for Advanced Materials and Devices (CAMD), Department of Chemistry, University of Colombo, Sri Lanka, <sup>2</sup>UCL School of Pharmacy, University College London, 29-39 Brunswick Square, London WC1N 1AX, UK.

**Background:** Rapid hemostasis is essential as a strategy for optimal recovery from hemorrhages and for this purpose hemostatic wound dressings can be used. Simultaneous delivery of antibacterial and analgesic drugs through the same dressing would provide prophylaxis against infections while providing pain relief to the patient. On this regard, electrospinning is a versatile technique that can be used to generate such composite dressing materials.

**Objective:** To develop a series of electrospun novel hemostatic loaded wound dressing material consisting of poly(vinylpyrrolidone), ethyl cellulose, an anti-inflammatory drug, an antibacterial drug and the hemostatic agent Kaolin (Ka).

**Method & Materials:** A series of fibers with Ka at 0, 40, 50, 60 and 70 % w/w loading were prepared. Model drugs hydrocortisone and fusidic acid were simultaneously incorporated at fixed loadings of 1 and 2 % w/w, respectively. Fiber mats as negative controls were separately prepared as required for each activity assessment. Electrospinning conditions were optimized at a pump rate of 1.0 mlh<sup>-1</sup>, with a tip to collector distance of 16 cm and a voltage difference of 15.0 kV. The fiber series was subjected to plasma clotting assay, anti-bacterial assay and anti-inflammatory activity to determine its activity. Selected material was characterized by SEM, FT-IR/ATR and XRD analysis.

**Results:** *In-vitro* drug release studies for the mats conducted in pH 7.4 phosphate buffered saline gave sustained drug release profiles with release over 120 hours for both drugs which vary in accordance of the loading of Ka in the fiber formulation. All formulations loaded with the two drugs showed antibacterial activity against Gram positive *Staphylococcus aureus* (ATCC 25923) and protection (hemolysis <2%) when subjected to the heat-induced hemolysis method using human red blood cells. The formulation with 60 % w/w of Ka gave a clotting time which is 2.88x faster than that for the control.

**Conclusion:** The novel electrospun PVP/EC/Ka system shows good potential as wound dressing materials with triple hemostatic, anti-inflammatory and antibacterial activity.

## OP 24

### **Molecular characterization of environmental *Leptospira* isolated from selected areas of Rathnapura District, Sri Lanka**

Wanigarathna GUS<sup>1</sup>, Herath T<sup>2</sup>, Rathnayake NS<sup>2</sup>, Bandara RMVV<sup>2</sup>, Vijeyakumaran R<sup>2</sup>, Karunadasa AKUP<sup>2</sup>, Gamage CD<sup>2\*</sup>

<sup>1</sup>Department of Medical Laboratory Science, Faculty of Allied Health Sciences, University of Peradeniya, Sri Lanka,

<sup>2</sup>Department of Microbiology, Faculty of Medicine, University of Peradeniya, Sri Lanka.

**Background:** Leptospirosis is a notifiable zoonotic infection in Sri Lanka and is caused by helical bacteria, *Leptospira* spp. Animals and humans are infected by exposure to the urine of infected animals. Rathnapura district is significant in high humidity and frequent heavy rains that preserve high soil moisture and flooding. This facilitates the spread of pathogenic leptospires from water sources and may pose a major threat to humans.

**Objective:** The primary goal was to investigate the risk of pathogenic leptospires coming into contact with surface water. Isolation of leptospires, molecular characterization of isolated leptospires, and mapping risk areas based on GPS and molecular data were the specific objectives.

**Methods & Materials:** Forty-two water samples were collected from pre-defined areas in Rathnapura district and cultured in EMJH medium for isolation. Microscopy-positive samples were subject to molecular characterization using the *flaB*-PCR that amplifies the gene both from pathogenic and intermediate-pathogenic species. PCR amplicons were subjected to DNA sequencing and a phylogenetic tree was constructed to reveal species.

**Results:** The total number of spirochete-positive samples in EMJH medium under dark field microscopy was 21/42 (50%), from which *flaB*-PCR was positive for 10/21 (47.6%). Six isolates were obtained from the 10 PCR-positive samples. PCR-positive areas were found in Parakaduwa, Meneripitiya and Pathberiya *gramaniladhari* divisions in Kuruwita MOH area. Phylogenetic analysis revealed that two isolates were pathogenic species, *Leptospira kmetyi* and *Leptospira interrogans*, while the remaining four isolates were intermediate-pathogenic species, *Leptospira wolffii* and *Leptospira licerasiae*.

**Conclusion:** This study revealed the presence of pathogenic and intermediate leptospires in environmental water sources. *Leptospira* spp., were isolated from the places where humans engaged in different activities such as paddy fields, wells, rivers, gem mines and sand quarries, which pose a potential risk to humans and other domestic animals.

## **OP 26**

### **COVID-19 chest computed tomography to detect and stratify severity score using computer aided detection system**

Chandrasiri NR\*, Kulatunga S

*Department of Radiography/ Radiotherapy, Faculty of Allied Health Sciences, University of Peradeniya, Sri Lanka.*

**Background:** Since COVID-19 is a global pandemic, COVID-19 diagnosis using computer aided detection (CAD) systems have been a remarkable achievement in clinical practice. As reported by many studies, CAD systems have been created using various medical images to detect COVID-19. But clinical decision support systems to calculate COVID-19 severity score have been less created.

**Objective:** This study aimed at developing a fast and accurate CAD system to calculate severity score and to investigate suitable features in COVID-19 detection using non-contrast computed tomography chest images.

**Methods & Materials:** Study was conducted using publicly available datasets in websites. In total, 212 slices from 61 patients (3 to 4 slices from each patient) were selected randomly which were marked as COVID-19 by radiologists. The CAD system performance in COVID-19 severity calculation was evaluated according to accuracy with the scores given by radiologists previously. In addition to severity score calculation, 8 texture and 6 gray level co-occurrence matrix (GLCM) properties in the segmented lung region of each image were calculated purposely to investigate suitable features for COVID-19 detection based on linear regression model.

**Results:** The CAD system to calculate severity score provided 100% accuracy which was comparable with the radiologists' reports. Thus, it is highly indispensable to highlight its accuracy in severity score calculation. Out of 212 images 8 images received 0 score while 50, 54 and 52 images received 1, 2 and 3 severity scores respectively. 18 images received severity score 4 and 30 images received severity score 5. As found 5 texture and 4 GLCM properties were suitable for a CAD since  $R^2$  value in linear regression model of each feature is  $>0.05$ .

**Conclusion:** In conclusion, this CAD system would be particularly beneficial in detection and severity score calculation of COVID-19 since it is fast and accurate tool in clinical practice and would ease the burden in clinical practice.

## OP 27

### Development of herbal green tea products with fruit of *Annona muricata* (Katu anoda) and *In vitro* evaluation

Madhushani KLC\*, Hettihewa SK

Department of Pharmacy, Faculty of Allied Health Sciences, University of Ruhuna, Sri Lanka.

**Background:** Herbal tea is one of the numerous varieties of tea products and is made from a combination of dried plant parts that have medicinal properties.

**Objective:** To develop herbal green tea bags incorporated with freeze-dried fruit powder of *Annona muricata* (Katu anoda) followed by *in-vitro* evaluation of total phenolic, flavonoid contents and radical scavenging activity.

**Methods & Materials:** The fruit sample was collected from Galle District in Sri Lanka. The freeze-dried powder of the fruit sample (100%, 75%, 62.5%, 50%, 25%) was incorporated with green tea in different composition to prepare five different tea bags. The crude infused hot water extracts were obtained and subjected to preliminary phytochemical tests. The total phenolic content (TPC), total flavonoid content (TFC) and *in-vitro* radical scavenging activity of the infused water extracts were evaluated by Folin-Ciocalteu assay, Aluminium Chloride Colorimetric method, and 2,2-diphenyl-1-picrylhydrazyl (DPPH) assay respectively. The values were compared to tea bag prepared with 100% green tea. SPSS 20 was used.

**Results:** The preliminary phytochemical screening exhibited the presence of phenolic compounds, flavonoids, tannins, steroids, saponins, proteins and carbohydrates. The highest total phenolic content {4596.23±71.77 mg Gallic acid equivalent (GAE)/100 g dry weight (DW) of tea bag}, TFC {1112.51±33.76 mg Catechin equivalents (CAE)/100 g DW of tea bag} and radical scavenging activity {19.9±0.279 mmol Trolox equivalents/100 g DW of tea bag} were exhibited by the infused aqueous extract obtained from the tea bag with the ratio of 75% (tea): 25% (fruit) while the values shown by green tea bag prepared with 100% were {4770.081±136.10 mg Gallic acid equivalent (GAE)/100 g dry weight (DW) of tea bag}, TFC {1473.82±41.75 mg Catechin equivalents (CAE)/100 g DW of tea bag} and radical scavenging activity {22.29±0.193 mmol Trolox equivalents/100 g DW of tea bag} respectively. There is a significant difference between the test and 100% green tea.

**Conclusion:** Green tea bags incorporated with the fruit have high values of TPC, TFC and radical scavenging activity. They can be recommended to use as alternative for green tea bags for those who do not like green tea flavour.

## OP 28

### Identification of biofilm forming uropathogens in patients’ urinary catheters and analysis of their exopolymer matrix

Maduwanthi TLM<sup>1</sup>, Perera GCMK<sup>1</sup>, Nissanka NMC<sup>2,5</sup>, Wijesinghe GK<sup>3</sup>, Weerasekera DD<sup>4</sup>, Weerasekera MM<sup>2</sup>, Dilhari KAA<sup>5\*</sup>

<sup>1</sup>Department of Medical Laboratory Sciences, Faculty of Allied Health Sciences, University of Sri Jayewardenepura, , Sri Lanka, <sup>2</sup>Department of Microbiology, Faculty of Medical Sciences, University of Sri Jayewardenepura, , Sri Lanka, <sup>3</sup>Bristol Dental School, University of Bristol, United Kingdom, <sup>4</sup>Department of Surgery, Faculty of Medical Sciences, University of Sri Jayewardenepura, Sri Lanka, <sup>5</sup>Department of Basic Sciences, Faculty of Allied Health Sciences, University of Sri Jayewardenepura, Sri Lanka.

**Background:** Catheterization is known as the primary source for hospital acquired urinary tract infections (UTI) in Sri Lanka. More importantly when the catheterization is prolonged it leads to biofilm-associated UTI. Biofilm associated infections are always troublesome as most of these biofilm forming bacteria are not responding to common antibiotics.

**Objective:** The study aimed to investigate the biofilm-forming uropathogens in patients’ urinary catheters and to analyse the exopolymer matrix formed by selected uropathogens.

**Methods & Materials:** A descriptive cross-sectional study was carried out with catheter tip samples collected from 71 patients at the time of removal of urinary catheters. Uropathogens were phenotypically identified by culture-dependent method. Biofilm-formers were tested by Crystal-violet (CV) and 3-(4,5-dimethylthiazol-2-yl)-2,5-diphenyl tetrazolium bromide (MTT) assays. Fourier transform infrared (FTIR) spectroscopy was used to determine the molecular composition of biofilm-exopolymer matrix of selected uropathogens.

**Results:** Catheterized patients were between 18-80 years, with mean  $\pm$ SD age of 58.43 $\pm$ 15.27 years. The majority were females (46/71; 65%). Out of 71 samples, 25 showed pure microbial growth, while 46 showed mix growth. Out of 113 isolates identified from all 71 samples, 93 (82%) were bacteria and 20 (18%) were *Candida* species. Coagulase-Negative Staphylococci (CNS) (22/71;31%) were predominant followed by *E.coli* (8/71;11%), *Pseudomonas* (8/71;11%), *S.aureus* (8/71;11%), Streptococci (25/71;35%), *Klebsiella* (10/71;14%), *Proteus* (12/71;17%), *C.albicans* (20/71;28%). All 113 isolates were identified as biofilm positive strains by CV assay while MTT assay identified 102/113 (90%) isolates as biofilm positive strains. CNS (22/71;31%) had the highest biofilm-forming potential followed by *E. coli* (8/71;11%), *Pseudomonas* (5/71;7%), *S. aureus* (8/71;11%), Streptococci (25/71;35%), *Klebsiella* (9/71;13%), *Proteus* (11/71;16%), *C. albicans* (18/71;25%). FTIR analysis showed the presence of O-acetyl ester, carboxylic, hydroxyl, C-H functional groups, primary secondary amines revealing the presence of protein, carbohydrate, lipids in the exopolymer matrix of biofilm formers.

**Conclusion:** CNS was the most frequently isolated biofilm-forming uropathogen in this study. Biofilm exopolymer matrix was composed of high abundance of proteins, polysaccharides and lipids. This study has potential clinical relevance for the easy diagnosis and management of catheter associated biofilm infections.

## PP 1

### **Perception on body-image among undergraduates in selected faculties of a state university in Sri Lanka**

Akurugodagama MS<sup>1\*</sup>, Munasinghe HC<sup>1</sup>, Silvapulle WS<sup>1</sup>, Hansika HMS<sup>1</sup>, Siddeek NF<sup>1</sup>, Shiyam A<sup>2</sup>, Amarasinghe Waas MDI<sup>3</sup>, Seneviwickrama KLMD<sup>2</sup>

<sup>1</sup>Faculty of Medical Sciences, University of Sri Jayewardenepura, Sri Lanka, <sup>2</sup>Department of Community Medicine, Faculty of Medical Sciences, University of Sri Jayewardenepura, Sri Lanka, <sup>3</sup>Department of Psychiatry, Faculty of Medical Sciences, University of Sri Jayewardenepura, Sri Lanka.

**Background:** Perception on body-image; the way individuals see or feel about their own physical appearance, can influence on one’s mental well-being, self-esteem and lifestyle. Since there is a dearth of research on this in Sri Lanka, the perception of body-image among undergraduates, who are an active social group, demands comprehensive understanding.

**Objective:** To describe the perception on body-image among undergraduates in selected faculties of a state university in Sri Lanka

**Methods & Materials:** A descriptive cross-sectional study was conducted among 389 undergraduates selected through convenience sampling from the faculties of Applied Sciences, Medical Sciences, Management & Commerce, and Humanities & Social Sciences of the University of Sri Jayewardenepura, Sri Lanka. Data were collected through a validated, pre-tested, self-administered questionnaire circulated as a Google-form via social media. Perception on body-image, mental well-being and self-esteem were assessed using Body-Focused Shame and Guilt Scale (minimum 0, maximum 88, cut-off 37), WHO-5 well-being index (minimum 0, maximum 100, cut-off 40), and Rosenberg self-esteem scale (minimum 10, maximum 40, cut-off 28) respectively. All attributes were dichotomized using the means obtained at the pilot test. Data were analyzed and presented using medians, IQR and % as appropriate.

**Results:** The majority of the participants were females (n=270, 69.4%). Median age was 23 years (IQR=4). Most of them (n=242, 62.2%) perceived their BMI as normal and showed a positive perception on body image (n=234, 60.2%). However, two of every five undergraduates tend to have a negative perception on their body-image. Further, 65.3% of the participants had been subjected to body-shaming. Among the participants who had a negative perception on their body-image, 69.0% had a poor mental well-being, 72.3% had poor self-esteem, and 61.3% were concerned of their fashion and cosmetics to improve their appearance.

**Conclusion:** Negative perception on body image is a hidden problem among undergraduates in Sri Lanka.

.

## PP 2

### **Quality of life of school teachers during COVID-19 pandemic in Biyagama educational division, Gampaha District, Sri Lanka**

Sewwandi WKJ\*, Ilankoon IMPS

*Department of Nursing and Midwifery, Faculty of Allied Health Sciences, University of Sri Jayewardenepura, Sri Lanka.*

**Background:** School teachers had to face a massive shift from traditional teaching methods to online teaching during the COVID-19 pandemic. This may cause an impact on their Quality Of Life (QOL).

**Objective:** This study aimed to assess the level of QOL among school teachers during the COVID-19 pandemic.

**Methods & Materials:** A community-based descriptive cross-sectional study was conducted in schools in Biyagama educational Division, Gampaha District, Sri Lanka. All teachers who teach grades 6-13 in Provincial schools in the 1AB category in Biyagama educational division were selected for this study. Data collection was done by using a google form including the validated Sinhala version of the World Health Organization Quality of Life BREF (WHOQOL-BREF) questionnaire via WhatsApp. The tool had four domains of health physical, psychological, environmental and social. Overall QOL maximum score was 5. Domain scores were scaled in a positive direction; higher scores denoted higher QOL which was 100. Data were analyzed using the SPSS software version 26.

**Results:** Three hundred and twelve teachers participated in the study (Response rate=72.6%). The mean age of participants was 39 (SD±7.65) years. Nearly half of the study participants had working experience as a teacher for more than 10 years (n=166, 53.2%). The WHOQOL-BREF mean scores for overall QOL was 3.6 (SD±0.7). The results of the four domains of the QOL revealed that the social relationship domain had the highest mean score of 68.4 (SD±15.86), physical health had the second-highest level of 68.3 (SD±11.12), Psychological health was 67.07 (SD±13.03), while environmental health showed the lowest mean score (M=61.63, SD±13.48).

**Conclusion:** The study concluded that, school teachers had a moderate level of overall QOL. QOL among teachers should be enhanced by psychosocial programs and providing a support system, especially during the transition from traditional teaching to hybrid or online teaching methods.

#### **PP 4**

### **Knowledge on transmission of COVID-19 among employees in selected garment factories in Sri Lanka**

Tennakoon TMWV<sup>1\*</sup>, Seneviwickrama KLMD<sup>2</sup>

<sup>1</sup>*Faculty of Allied Health Sciences, University of Sri Jayewardenepura, Sri Lanka,* <sup>2</sup>*Faculty of Medical Sciences, University of Sri Jayewardenepura, Sri Lanka.*

**Background:** The COVID-19 pandemic caused a negative impact on the Sri Lankan garment industry. In October 2020, the second wave of COVID-19 was reported from one of the largest apparel manufacturers in Sri Lanka. Knowledge on transmission of COVID-19 is important in its prevention.

**Objective:** To describe the level of knowledge on transmission of COVID-19 among employees in selected garment factories in Sri Lanka.

**Methods & Materials:** A descriptive cross-sectional study was conducted among 422 employees in a conveniently selected sample from three main garment factories in Sri Lanka. Knowledge was assessed using a validated, interviewer-administered questionnaire that consisted of 34 components. For each incorrect statement a score of 0 was given, and for each correct statement, a score of one was given. The total score was converted into a percentage. Therefore, the range of scores was 0 to 100. Knowledge was dichotomized as ‘Good’ ( $\geq 66\%$ ) and ‘Poor’ ( $\leq 66\%$ ) based on the mean knowledge score of the pilot study. Data were analyzed using SPSS version 26 and summarized using descriptive statistics.

**Results:** The response rate was 93% (n=391). The majority (64%, n=250) were females and 63% (n=247) of the participants were unmarried. The majority (53%, n=206) had a good level of knowledge regarding the transmission of COVID-19. Most of the participants (n=371, 94.89%) knew that COVID-19 spread through respiratory droplets. However, 89.57% (n=350) did not know that coronavirus is not an airborne disease. The majority of the participants (71%, n=278) knew that the disease can be spread by asymptomatic patients.

**Conclusion:** The majority of garment employees had a good knowledge on COVID-19 transmission. The study recommends to provide health education regarding COVID-19.

## PP 5

### **Association between reproductive factors and CVD risk in non-menopausal and postmenopausal women with type 2 Diabetes Mellitus**

Weerawickrama PK<sup>1\*</sup>, Weerasinghe WMCP<sup>1</sup>, Fernando IKAS<sup>1</sup>, Bulugahapitiya U<sup>2</sup>, Garusinghe C<sup>3</sup>, Karunarathna AMDS<sup>1</sup>, Abeyrathne D<sup>3</sup>

<sup>1</sup>Faculty of Allied Health Sciences, General Sir John Kotelawala Defence University, Sri Lanka, <sup>2</sup>National Hospital of Sri Lanka, <sup>3</sup>Colombo South Teaching Hospital, Sri Lanka.

**Background:** Cardiovascular disease (CVD) is a leading cause of mortality among women with type 2 diabetes mellitus (T2DM).

**Objective:** The main aim of this study was to determine the association between reproductive factors and the risk of developing CVDs in women with T2DM.

**Methods & Materials:** The CVD risk was assessed in 293 women with T2DM attending the Colombo South Teaching Hospital using the Framingham Risk Score (FRS). The data relating to known CVD risk factors and reproductive factors were collected. The correlations were assessed using Pearson’s correlation. Multiple regression analysis was performed to identify the risk factors.

**Results:** The prevalence of dyslipidemia, raised LDL cholesterol level, hypertriglyceridemia, low HDL cholesterol level, hypertension, overweight, and central obesity were 25.9%, 41.3%, 33.1%, 19.5%, 54.9%, 50.8% and 98.0% respectively. Only 17.06% women achieved the three therapeutic targets (fasting blood glucose <126 mg/dl), blood pressure (systolic blood pressure < 140 mmHg, diastolic blood pressure (DBP) < 90 mmHg), and blood lipids (total cholesterol < 240 mg/dl, LDL <100 mg/dl). The CVD risk was significantly high among postmenopausal women when compared to non-menopausal women (p<0.001). Menopause status, gestational DM, use of hormonal contraceptives and age at menopause were significantly correlated with the CVD risk (p<0.001). The multiple linear regression analysis showed that menopause status ( $\beta = 0.325$ , p< 0.001), DBP ( $\beta = 0.340$ , p<0.001), LDL/HDL ( $\beta = 0.362$ , p< 0.001), and time since menopause ( $\beta = 0.224$ , p< 0.001) were risk factors for future CVD risk for all the women. Among the postmenopausal group (n =222), DBP ( $\beta = 0.353$ , p<0.001), LDL/HDL ( $\beta = 0.418$ , p < 0.001), and time since menopause ( $\beta = 0.221$ , p < 0.001) were found to be risk factors for CVD risk.

**Conclusion:** The high CVD risk among post-menopausal women is contributed by high DBP, high LDL/HDL ratio and increased time since menopause

## **PP 6**

### **Empathy level and associated factors among medical undergraduates of University of Sri Jayewardenepura**

Gunathunga ND<sup>1</sup>, Kuruppu KDRTM<sup>1</sup>, Wijesuriya MWAHS<sup>1</sup>, Nanayakkara SK<sup>1</sup>, Irosh BU<sup>1</sup>, Edirisinghe EAST<sup>3</sup>, Shiyam A<sup>2</sup>, Seneviwickrama KLMD<sup>2</sup>

<sup>1</sup>Faculty of Medical Sciences, University of Sri Jayewardenepura, Sri Lanka, <sup>2</sup>Department of Community Medicine, Faculty of Medical Sciences, University of Sri Jayewardenepura, Sri Lanka, <sup>3</sup>Department of Anatomy, Faculty of Medical Sciences, University of Sri Jayewardenepura, Sri Lanka.

**Background:** Empathy, the ability to understand and share the feelings of another, is a critical factor in enhancing the doctor patient relationship. It helps to increase the precision in diagnosis as the patient tends to easily open up towards a kind physician.

**Objective:** To describe empathy level and its associated factors among medical undergraduates of University of Sri Jayewardenepura.

**Methods & Materials:** A cross-sectional study was conducted among 221 medical undergraduates in university of Sri Jayewardenepura using a validated, self-administered Google form shared via social media groups. Empathy and stress levels were assessed using 20-item Jefferson Scale of Physician Empathy student version (JSPE-S) and the perceived stress scale. Possible maximum and minimum score for JSPE is 140 and 20 respectively. Data was analyzed using SPSS software (26<sup>th</sup> version). Empathy scores were presented as Mean with SD. Independent sample t-test was used to compare mean empathy scores between different categories. Level of significance was taken as  $p < 0.05$ .

**Results:** The majority (65.6%,  $n=145$ ) were females, Sinhalese (89.6%  $n=198$ ) with clinical exposure (65.2%,  $n=144$ ). Mean empathy score ( $\pm$ SD) was 107.97 ( $\pm$ 15.98). Mean stress score ( $\pm$ SD) was 22.77 ( $\pm$ 3.50). Empathy scores were significantly associated with place of residence during academics ( $p=0.005$ ) and relationship status ( $p=0.026$ ). Gender ( $p=0.05$ ), ethnicity ( $p=0.182$ ), clinical exposure ( $p=0.537$ ), academic achievement ( $p=0.772$ ) and perceived stress ( $p=0.249$ ) were not significantly associated with empathy scores.

**Conclusion:** Medical students in university of Sri Jayewardenepura had low empathy level compared to western countries. Emphasis should be given in their curriculum to activities targeted at inculcating empathy.

## **PP 7**

### **Satisfaction of E-learning and associated factors among nursing undergraduates during COVID-19 pandemic in selected state universities of Western Province, Sri Lanka**

Alahakoon ANJ\*, Meegoda MKDL

*Faculty of Allied Health Sciences, University of Sri Jayewardenepura, Sri Lanka.*

**Background:** The COVID-19 pandemic posed a major challenge to the global education system. Most of the educational institutes around the world had to discontinue their face to face teaching and change learning methods to online learning during this period.

**Objective:** The study aimed to assess the satisfaction of E-learning and associated factors among nursing undergraduates during COVID-19 pandemic in selected universities of Western Province Sri Lanka.

**Methods & Materials:** A descriptive cross-sectional study was conducted among 395 undergraduate nursing students using a web-based/online survey. The study setting was selected conveniently. A validated, pre-tested self-administered questionnaire (Google form) was sent to all the nursing undergraduates in University of Sri Jayewardenepura and University of Colombo. SPSS version 26 software was used for data analysis. The data were summarized by using descriptive statistics. Chi-square tests were used to determine the association between the variables. Significance level was set at 0.05.

**Results:** The response rates of the participants were 93.6 %. The majority of the participants (n=298, 75.4%) were females. Smart phone was the most common device used (n=328, 83.0%) by the participants for online learning. Most of the respondents (n=168, 42.5%) agreed with the clarity of the lecture material provided through online, while 44.1% participants were satisfied with guidance services of the lecturers. More than half (50.1%) of the participants were having satisfaction on E-learning. A statistically significant association was seen between gender and satisfaction on E-learning ( $p=0.024$ ). Most of the (n=159) female participants had a good level of satisfaction on E-learning than male participants.

**Conclusion:** The majority of undergraduate nursing students in the selected state universities of Western Province are satisfied with the E-learning they have received during the COVID-19 pandemic. There is a significant association between gender and satisfactions on E-learning.

## PP 8

### **Impact of emotional intelligence on caring behavior among government nursing officers in Teaching Hospital Anuradhapura**

Dissanayake RY<sup>1</sup>, Herath HMASK<sup>2</sup>, Jayathissa, PPSK<sup>1</sup>, Kethikenella KGSS<sup>1</sup>, Wijayasundara WMSK<sup>3\*</sup>, Priyanthi WN<sup>4</sup>

<sup>1</sup>Teaching Hospital, Anuradhapura, Sri Lanka, <sup>2</sup>General Hospital Ampara, Sri Lanka, <sup>3</sup>College of Nursing, Anuradhapura, Sri Lanka, <sup>4</sup>The Open University, Sri Lanka.

**Background:** The concept of caring is the core of nursing. Caring for others is stressful work. Research has shown that nurses are leaving practice and have identified job-related stressors which lead to decreases the quality of care, produces negative outcomes, and leads to a decline in displaying Caring Behaviors (CB). Emotional Intelligence (EI) a rising field of study that includes the recognition, understanding, expression, and management of emotions, may offer plausibility for effectively navigating occupational stress.

**Objective:** To investigate the impact of EI on CB among registered nurses at Teaching Hospital Anuradhapura.

**Methods & Materials:** The quantitative descriptive cross-sectional survey was conducted among randomly selected 422 registered nurses at Teaching Hospital Anuradhapura. Validated and pretested Emotional Intelligence Questionnaire-Short Form (EIQue-SF) which included seven categories and the Caring Behaviors Inventory-24 scale (CBI-24) which included four categories were used for assessing the degree of emotional intelligence and caring behaviors, respectively. Data were analyzed using SPSS-V 26 with descriptive and inferential statistics such as t-test, ANOVA and multiple regression test. The level of significance was set at < 0.05. Ethical approval was obtained from the Rajarata University of Sri Lanka.

**Results:** Response rate was 92% (n= 392). The majority of the participants were female (83.6%), in their 31-35 years age group (28%), with 2-5 years of work experience (23%). Among them, the majority of (60%) participants were at a high level of EI while 40% of the participants were an average level of EI. In terms of CB, 19% participants were at a high level while 81% participants were at a very high level based on the previous study categorisation. There is a significant difference in working place (p=0.010), age group (p=0.036), and educational qualifications (p=0.024) with EI. The only significant difference was identified in the age group (p=0.016) with CB. The caring behavior slightly predict by EI (P=0.038, R<sup>2</sup> = 3.1%).

**Conclusion:** EI was found to be at an average level and CB at very high level. The hospital can support the development of emotional intelligence aspect through any kind program of emotional self-control for nurses.

## PP 9

### **Level of self-directed learning and associated factors among nursing students in three selected colleges of nursing in Sri Lanka**

Dissanayaka HMPN<sup>1</sup>, Ekanayaka EMCK<sup>2</sup>, Kumari WPP<sup>3</sup>, Thennakoon TMLG<sup>4</sup>, Wijayasundara WMSK<sup>5\*</sup>, Samarasekara PWGDP<sup>6</sup>

<sup>1</sup>Divisional Hospital Galenbidunuwewa, Sri Lanka, <sup>2</sup>Base Hospital Kekirawa, Sri Lanka <sup>3</sup>Base Hospital Thambuththegama, Sri Lanka, <sup>4</sup>Provincial Health Training Center, Anuradhapura, <sup>5</sup>College of Nursing, Anuradhapura, Sri Lanka, <sup>6</sup>The Open University of Sri Lanka.

**Background:** Nursing students are to be prepared for rapidly changing and complex healthcare environment. Self-Directed Learning (SDL) has been identified as an important ability for nursing students for lifelong learning and plays an important role in nursing education for academic achievement, communication self-efficacy, assertiveness and responsibility. However, no study has documented on the need for preparation of nursing students in the rapidly changing healthcare system in Sri Lanka.

**Objective:** To investigate the level of readiness for self-directed learning and associated factors among nursing students in three selected Colleges of Nursing in Sri Lanka.

**Methods & Materials:** A quantitative- cross-sectional descriptive research design was carried out with randomly selected 422 nursing students from three Colleges of Nursing; Anuradhapura, Kurunegala, and Kandana. Validated Self Directed Learning Readiness tool was selected for data collection and data analysis was done using SPSS 26 version. Ethical approval was obtained from the Ethics Review Committee, Rajarata University of Sri Lanka. The level of significance was set at  $p < 0.05$ .

**Results:** Response rate was 100% ( $n=422$ ). Most of the participants were female (92.2%), Sinhalese (98.8%), Buddhist (94.5%), and in 24-25 years age category (75.6%). The majority of the students reported an average level of readiness for self-directed learning (62.5%). Academic environment frequently affected their self-directed learning rather than personal factors and social factors. There was a positive low degree significant relationship between SDL and other factors; academic environment ( $r = 0.306$ ,  $p < 0.001$ ), personal factors ( $r = 0.370$ ,  $p < 0.001$ ), and social factors ( $r = 0.241$ ,  $p < 0.001$ ).

**Conclusion:** The results of this study showed that the SDL in nursing students was at a moderate level, mostly affected by academic factors. The findings provide evidence to nurse educators to include self-directed learning in nursing courses, to improve teaching and learning methods, and to promote life-long learning for nurses.

## PP 10

### **The effect of sleep deprivation on short-term memory of undergraduates of KIU, Sri Lanka**

Kumara KMDD<sup>1</sup>, Boralugoda SYM<sup>1</sup>, Zahir MRM<sup>1</sup>, Sara AF<sup>1</sup>, Madulakkhana DDK<sup>1</sup>, Dunukara DMJDK<sup>1\*</sup>, Priyadarshani AMB<sup>2</sup>

<sup>1</sup>Department of Biomedical Sciences, Faculty of Health Sciences, KAATSU International University (KIU), Sri Lanka,

<sup>2</sup>Department of Medical Laboratory Sciences, Faculty of Allied Health Sciences, University of Sri Jayewardenepura, Sri Lanka.

**Background:** A good night's sleep is necessary for good physical and mental health, thereby, a good quality life. Assessment on the impact of sleep deprivation on short-term memory of undergraduate students is important for their academic success.

**Objective:** To determine the effect of sleep deprivation on short-term memory of undergraduates of KAATSU-Highly Advanced Medical Technology Training Centre (KIU), Sri Lanka.

**Methods & Materials:** A descriptive cross-sectional study was conducted among undergraduates of KIU. The data were collected through a validated, pre-tested, structured questionnaire in the mode of "Google form" which consisted of (i) Demographic data (ii) Sleep status evaluation (iii) Short-term memory evaluation. Undergraduates with sleep and memory disorders were excluded from the study. A total of 218 undergraduates were recruited using a convenient sampling method. Results were analyzed using SPSS 25 version. The descriptive statistics included frequencies and percentages, while inferential statistics included independent-sample t-tests.

**Results:** The response rate was 80.7%. Distribution of participants among the faculties was as follows; Health Science (n=144), Management (n=46), Computer Science and Engineering (n=15), Graduate Studies (n=8), Education and Language (n=5). Among the participants (n=218), 163 (74.8%) undergraduates had adequate sleep, while 55 (25.2%) had inadequate sleep. A statistically significant correlation was found between sleep hours and short-term memory ( $p < 0.001$   $r = 0.301$ ). Further, a statistically significant association was observed between sleep status and gender ( $p = 0.002$ ). No significant association was found between sleep status and the faculty ( $p = 0.537$ ) and sleep status and the academic year ( $p = 0.913$ ). Statistically significant difference in mean values of short-term memory scores between inadequate and adequate sleep groups was observed ( $p < 0.05$ ). The adequate sleep group showed  $0.88 \pm 1.6$  value of short-term memory score, while the inadequate sleep group showed a value of  $0.77 \pm 0.22$ .

**Conclusion:** The students with adequate sleep had a better short-term memory compared to the students with inadequate sleep.

## **PP 11**

### **Knowledge, attitudes and practices on urinary tract infections among school teachers in selected schools in Kuliyaipitiya and Giriulla, Sri Lanka**

Safwan SM<sup>1</sup>, Dias NTB<sup>2</sup>, Dilhari KAA<sup>2\*</sup>

<sup>1</sup>Department of Nursing and Midwifery, Faculty of Allied Health Sciences, University of Sri Jayewardenepura, Sri Lanka,

<sup>2</sup>Department of Basic Sciences, Faculty of Allied Health Sciences, University of Sri Jayewardenepura, Sri Lanka.

**Background:** Urinary tract infection (UTI) is the second most common infection in humans and causes millions of hospitalizations worldwide annually. Public awareness is an important factor to be considered in the prevention and management of UTIs.

**Objective:** The study aimed to assess the knowledge, attitudes and practices on UTIs among school-teachers in selected schools in Kuliyaipitiya and Giriulla educational zones, Sri Lanka.

**Methods & Materials:** A descriptive cross-sectional, pre-tested questionnaire-based study was carried out among 373 school teachers using convenient sampling. The questionnaire consisted of 14 questions to assess knowledge, 10 statements for attitudes, and 14 questions for practices regarding UTIs. The ‘good’ and ‘poor’ levels of the aspect were assessed according to a scoring method and statistical analysis was done using the independent sample t-test.

**Results:** The majority of the subjects (75.9%) were females. Nearly 80% of participants were aware that the development of UTIs is caused by the entry of microbes into the urinary tract whereas around 60% knew that bacteria are the most common causative agent. More than 75% of subjects believed that early detection and prompt treatment of UTIs help to reduce the risk of kidney infections. However, only about 42% were aware that females are more prone to get UTIs than males. More than 90% of the participants had positive attitudes regarding drinking of adequate amount of water, maintaining good personal hygiene, and consultation of a physician regarding signs and symptoms of UTI. Significant differences were found between the mean score of positive and negative attitude bearers in each question ( $p < 0.001$ ). More than 95% of the participants had practised good personal hygiene measures which are important in the prevention of UTIs.

**Conclusion:** Overall knowledge, attitudes and practices regarding UTIs among teachers were ‘good’. However, it is needed to improve the knowledge of school teachers, especially regarding the risk factors that can lead to UTIs.

## PP 12

### **Relationship between cardiopulmonary endurance and leisure time physical activity among A/L students in selected two rural schools in Batticaloa District**

Sarmi K<sup>1\*</sup>, Yashoda H<sup>2</sup>

<sup>1</sup>Faculty of Medicine, Department of Allied Health Sciences, University of Colombo, Sri Lanka, <sup>2</sup>Department of Paediatrics, Faculty Medicine, University of Colombo, Sri Lanka.

**Background:** Cardiopulmonary endurance is an indication of a person's total fitness. It is defined as the level at which heart, lungs and muscles work together when exercising for an extended period of time. Physical activity is defined as any movement produced by skeletal muscles that require energy expenditure. Cardiopulmonary endurance and physical activity are associated with many health-related benefits.

**Objective:** This study aimed to identify the relationship between cardiopulmonary endurance and leisure-time physical activity among A/L students in two selected rural schools in Batticaloa District to further confirm the results of previous studies.

**Methods & Materials:** A cross-sectional analytical study was carried out on two selected rural schools in Batticaloa District, Sri Lanka, consisting of 55 A/L students aged between 18-19 years. The simple random sampling method was used to select participants. Leisure-time physical activity was self-reported, and cardiopulmonary endurance was measured by using Young Men's Christian Association 3-minute step test. Ethical clearance was obtained from the Faculty of Medicine, University of Colombo. Data were analysed using descriptive statistics, independent sample t-test, Mann witney U test, and Pearson Chi square test on SPSS version 23. Significance level was set at  $p < 0.05$ .

**Results:** Complete data of 55 individuals (50.9% female) aged 18 to 19 years (mean  $18.57 \pm 0.39$  years) were considered for analysis. The mean resting heart rate and peak heart rate of the study sample were 72.38 (SD $\pm$ 9.94) and 93.47 (SD $\pm$ 12.72). In this sample, 58.2% reported high physical activity level, and 41.8% reported moderate physical activity level. The mean metabolic equivalent (MET) value was 4729.06 (SD $\pm$ 3831.79). The mean sitting hours of the population were 3.75 hours (SD $\pm$ 2.07 hours). Cardiopulmonary endurance had a significant correlation ( $p < 0.001$ ) with leisure time physical activity.

**Conclusion:** The present results suggest that cardiopulmonary endurance is associated with leisure-time physical activity. This finding emphasizes the importance of sufficient physical activity among adolescents in recreation for maintaining or improving cardiopulmonary endurance for health benefits.

## PP 13

### **Geriatric non-pharmacological mental healthcare practices used at Kaithady state home for elders in Sri Lanka**

Mayuri S<sup>1\*</sup>, Rajeetha M<sup>2</sup>

<sup>1</sup>Postgraduate Institute of Science, University of Peradeniya, Sri Lanka, <sup>2</sup>Government Siddha Medical College, Palayamkottai, Tirunelveli, Tamil Nadu, India.

**Background:** At the present children fail to look after their elderly dependent parents due to the busy life style and leave them in old age homes. In 2012, 24,535 out of 2,520,573 elders in Sri Lanka were institutionalized in elders’ homes. This type of negligence from familial love and affection causes mental and emotional elder abuse.

**Objective:** This study aimed to identify non-pharmacological mental healthcare practices used by the elders at old age homes to alleviate their mental health problems.

**Methods & Materials:** A cross-sectional survey was conducted with 70 elders who were not cognitively impaired using a convenience sampling method. Data were obtained from elders using validated self-administered questionnaires at Kaithady state home for elders situated in Jaffna District, Sri Lanka. Descriptive statistical data analysis was used.

**Results:** Of the sample, 57.14% (40) were males. Most of the elders (31.42%, n=22) belonged to 71 to 80 years age group. Among them, 64.29% (n=45) were married people, 71.11% (n=32) were widowed, and 40% (n=18) had no children. Out of 70 elders, 38.57% (n=27) were admitted to the old age home on their own will, and 40% (n=20) were admitted due to the absence of caregivers. Among 70 elders, 22.86% (n=16) experienced loneliness, 44.29% (n=31) faced psychological stress, and 50% (n=35) were sociable. Among 70 elders, 55.71% (n=39) engaged in religious coping activities only, 18.57% (n=13) engaged in religious coping and meditation, 4.29% (n=3) practiced breathing exercises and meditation, 14.29% (n=10) followed religious coping, breathing exercises and meditation and 7.14% (n=5) practiced religious coping, yoga, breathing exercise and meditation as non-pharmacological strategies to cope up with geriatric mental health issues.

**Conclusion:** Non-pharmacological approaches such as religious coping, meditation, breathing exercises, and yoga are practiced among the elders to alleviate mental health ailments. The need and impact of these approaches on the geriatric mental healthcare development of the country is high.

## **PP 14**

### **Knowledge on hand hygiene among healthcare professionals in the Western Province of Sri Lanka**

Wijerathne AM\*, Bandara RHMHK, Maddumage SP

*School of Physiotherapy, International Institute of Health Sciences, Welisara, Sri Lanka.*

**Background:** Hand hygiene is regarded as one of the most crucial infection control measures to avoid healthcare-associated infections.

**Objective:** The aim of this study was to assess the knowledge level on hand hygiene among healthcare professionals (HCP) in the Western Province of Sri Lanka.

**Methods & Materials:** A descriptive cross-sectional study was conducted among 100 healthcare professionals in Western Province, Sri Lanka using convenience sampling. Medical doctors, nurses, physiotherapists, and pharmacists who had at least one year of service were included into the study. The WHO hand hygiene knowledge questionnaire for healthcare workers was used and data was analyzed using SPSS version 25. Significance level was set at  $p < 0.05$ .

**Results:** A total of 100 participants ( $\text{age} \pm \text{SD} = 35.81 \pm 8.36$  years, 32% males and 68% females) participated in the study. The majority (50%) were nurses while 21%, 18% and 11% were medical doctors, physiotherapists and pharmacists respectively. A formal hand hygiene training was received by 89% of the participants during the last three years and there was a significant difference ( $p < 0.001$ ) between the history of formal training and the knowledge on hand hygiene. Only 40% of the HCPs properly identified unclean hands of them as the main route of the cross-transmission of pathogens and only 31% selected germs already present on or within the patient as the most frequent source of pathogens in a healthcare facility. However, 74% correctly identified 20 seconds as the minimal time needed for alcohol-based hand rub to kill most pathogens on hands.

**Conclusion:** Hand hygiene training programs can be conducted by health policy makers to enhance the knowledge and practices of hand hygiene.

**PP 15**

**Assessing the perceived vulnerability of nursing officers towards tuberculosis at the National Hospital for Respiratory Diseases in Welisara, Sri Lanka**

Priyadarshani NAW<sup>1,2</sup>, Assella IL<sup>1,3</sup>, Rukmani MWADT<sup>1,2</sup>, Fernando MRC<sup>1,2</sup>, Priyashanthi JM<sup>1,4</sup>  
Sandakumari HHHS<sup>1</sup>, Kanchana KTG<sup>1</sup>

<sup>1</sup>Department of Nursing, KAATSU International University (KIU), Sri Lanka, <sup>2</sup>District General Hospital Gampaha, Sri Lanka,

<sup>3</sup>National Hospital for Respiratory Diseases Welisara, Sri Lanka, <sup>4</sup>North Colombo Teaching Hospital, Ragama, Sri Lanka.

**Background:** Tuberculosis (TB) is a highly contagious infectious disease primarily caused by *Mycobacterium tuberculosis*. Tuberculosis satisfies the priority criteria of having a high magnitude, transcendence, and vulnerability.

**Objective:** To assesses the vulnerability of the nursing officers towards tuberculosis at the National Hospital for Respiratory Diseases in Welisara, Sri Lanka.

**Methods & Materials:** A cross-sectional study was conducted among 140 nurses recruited using the convenience sampling method. Data were collected using a pre-tested, interview-administered questionnaire which is comprised of a perceived vulnerability questionnaire. Ethical approval was obtained from the Ethics Review Committee of KIU (KIU/ERC/22/047) along with the permission of the hospital director. Volunteer participants were clearly informed of the purpose of the study and informed consent was obtained. Data were analyzed in the statistical package for Social Science (SPSS) version 25.

**Results:** The majority were aged between 41 years and 50 years (34%), females (96%), and with the working experience of 21-30 years (94%). Among the total participants, 8% and 7% of participants worked at TB and Multi Drugs Resistant Tuberculosis (MDR-TB) wards respectively. Most of them (56%) were diploma holders in nursing while 10% obtained special training. However, all of them had received training on “TB molecular”. More than 90% of the nurses had knowledge regarding symptoms of pulmonary tuberculosis, mode of transmission, risk factors, and control measures. It was found that 40% of participants had the least vulnerability, while 32.9% of participants had a low-risk vulnerability, and less number (27.1%) had a risk of vulnerability towards tuberculosis.

**Conclusion:** TB-related nurses’ knowledge was high and they were at the least vulnerable to TB.

## PP 16

### **Nursing informatics and learning health system among nurses during COVID-19 at selected higher education institute in Sri Lanka**

Harshani PK<sup>1,2</sup>, Damayanthi WRS<sup>1,3</sup>, Rathnayaka GHAN<sup>1,2</sup>, Sandakumari HHS<sup>1</sup>, Kanchana KTG<sup>1</sup>

<sup>1</sup>KAATSU International University (KIU), Sri Lanka, <sup>2</sup>National Hospital of Sri Lanka, Colombo, Sri Lanka, <sup>3</sup>Colombo South Teaching Hospital, Sri Lanka.

**Background:** Nursing informatics (NI) and learning health systems (LHS) facilitate the efficient flow of information, as well as the synthesis of resources that support evidence-based practice, patient safety, and professional growth. The COVID-19 pandemic has significantly impacted worldwide communities, posing significant healthcare difficulties.

**Objective:** To determine the usage of NI and LHS among nurses during the COVID-19 pandemic at selected Higher Education Institute in Sri Lanka.

**Methods & Materials:** A cross-sectional study was conducted among 203 registered nurses in Sri Lanka using a network sampling. Data were collected using a pre-tested, self-administered web-based questionnaire that was developed by the researchers. The questionnaire addressed nursing informatics and LHS which were the two parts of the questionnaire. Data were analyzed using SPSS 25 version. Ethical approval was obtained from the Ethics Review Committee of KIU.

**Results:** The majority were females (76%), and the mean  $\pm$ SD age was 34.1 $\pm$ 6.6 years. Most (79.3%) never had training in nursing informatics. A primary level of computer literacy was evident among 63.5% of the participants. Most of them (83.3%) used social media while the majority (95.6%) used mobile phones for day-to-day activities. The majority (95.6%) used electronic devices for patient care, and it was mainly for patient monitoring (84.7%). The majority mentioned (80.8%) that nursing administration, nursing research, and nursing education fields were affected during the COVID-19 period based on their perception. More than 50% of participants had positive attitudes regarding NI and LHS. Most of the participants (54.2%) believed that they have sufficient time to use nursing informatics tools and learn about health systems (62.6%). Regarding the practice of NI and LHS, 42.9% of respondents claimed that there were adequate resources.

**Conclusion:** Nurses in Sri Lanka had favorable opinions of the use and use of nursing informatics and the learning health system. When deploying the Nursing Informatic and Learning Health System among Sri Lankan nurses during COVID-19, neither notable obstacles nor modifications were found.

**PP 17**

**Demographic and clinical characteristics among type 2 diabetic patients, attending the Diabetic Centre, Teaching Hospital Jaffna**

Thivya K<sup>1\*</sup>, Risle MRF<sup>1</sup>, Samiya HM<sup>1</sup>, Arasaratnam V<sup>2</sup>, Aravinthan M<sup>3</sup>

<sup>1</sup>Department of Medical Laboratory Sciences, Faculty of Allied Health Sciences, University of Jaffna, Sri Lanka, <sup>2</sup>Department of Biochemistry, Faculty of Medicine, University of Jaffna, Sri Lanka, <sup>3</sup>Diabetic Centre, Teaching Hospital, Jaffna, Sri Lanka.

**Background:** Diabetic mellitus is a chronic systemic disorder that requires lifelong management. Failure to control demographic and clinical related risk factors can lead to diabetes-related complication.

**Objective:** The study aimed to find the demographic and clinical characteristics of type 2 diabetic patients, attending the Diabetic Centre, Teaching Hospital, Jaffna.

**Methods & Materials:** This was a descriptive cross-sectional study. A systematic random sampling method was used. A total of 300 patients were selected for this study. A validated interviewer administered questionnaire was used to collect data. Descriptive statistics and Chi-square test were used. Significance level was set at  $p < 0.05$ .

**Results:** Among the 300 patients, the majority were females ( $n=193$ ). The age of patients ranged between 28 to 86 years with the mean ( $\pm$ SD) of 58.62 ( $\pm$ 11.22) years. The majority were Sri Lankan Tamils (95.7%) and married (95.3%). Among the patients, 60% had secondary education, and 55.7% were from rural areas. Monthly income of 73% of the patients were  $\leq$ LKR 24,999. The mean BMI ( $\pm$ SD) of the selected patients was 25.58 ( $\pm$ 4.57)  $\text{kg/m}^2$  and was under the category of overweight. Further, 138 and 53 patients with normal and overweight BMI had good and poor glycaemic control respectively ( $p < 0.001$ ). Both diabetic neuropathy and retinopathy were presented in 19.3% of patients with duration of DM more than 10 years, while 4.6% of patients had both complication with the duration of less than 5 years ( $p < 0.001$ ). Of the sample, 57.3% were hypertensive while the majority (82%) of them had poor glycaemic control. Moreover, 4% and 1.4% of the patients had insulin therapy with the DM duration of more than 10 years and less than 5 years respectively.

**Conclusion:** Hypertension and overweight were more prevalent among diabetes patients and the quality of glycaemic control is commonly poor in these patients. Diabetic neuropathy and retinopathy were more prevalent with the increased duration of DM.

**PP 19**

**Knowledge of Iron deficiency anemia management among pregnant women in Narahenpita area, Sri Lanka**

Kumaran M\*, Rajapakshe NY, Saeed S, Khaleel ZA

*School of Nursing, International Institute of Health Sciences, Welisara, Sri Lanka.*

**Background:** Anemia is a medical disorder where insufficient red blood cells transport oxygen throughout the human body tissues. This is considered as one of the most common disorders in pregnant women as the baby develops and blood volume is expanded to prepare for blood loss.

**Objective:** The main goal was to assess the knowledge on the management of iron deficiency anemia (IDA) in pregnant women and to assess the food habits of all the pregnant women.

**Methods & Materials:** A descriptive cross-sectional study was performed based on the knowledge of IDA management in pregnant women. Electronic google forms were used for data collection. An interview-administered questionnaire including both open-ended and closed-ended questions was administered to all the pregnant women who were willing to participate between the age of 23 to 45 years in the Narahenpita MOH. The sample size of 250 was derived with CI= 95% and population size of 2100 using the Raosoft application.

**Results:** Out of 250 patients, a total of 65 pregnant mothers actively participated in the questionnaire study based on their preferred language. Out of the 65 pregnant mothers, the overall and the main demographic results indicated 69.2% (n=45) of the pregnant mothers were aware of the management of IDA rest of the 30.8% (n=20) mothers were not aware of IDA management. Meanwhile, 86.2% (n=56) of pregnant mothers had knowledge related to anemia but 13.8% (n=9) mothers did not have adequate knowledge of anemia. Based on the specific objective-wise results knowledgeable pregnant mothers knew that IDA can be managed by consuming iron-rich foods such as red meat, spinach, and fish, and taking iron supplements.

**Conclusion:** The majority of pregnant mothers had a proper knowledge with respect to the management of IDA at the Narahenpita MOH hospital. Therefore knowledgeable pregnant mothers have low chances of getting diagnosed with IDA.

**PP 20**

**Anemia and its etiological factors among elderly individuals attending the Family Practice Centre at the Faculty of Medical Sciences, University of Sri Jayewardenepura**

Karunasena DKG<sup>1\*</sup>, Sewwandi KKD<sup>1</sup>, Fernandopulle B<sup>2</sup>, De Silva H<sup>3</sup>, Darshana LGT<sup>1</sup>

<sup>1</sup>Department of Medical Laboratory Sciences, Faculty of Allied Health Sciences, University of Sri Jayewardenepura, Sri Lanka, <sup>2</sup>Department of Pathology, Faculty of Medical Sciences, University of Sri Jayewardenepura, Sri Lanka, <sup>3</sup>Department of Family Medicine, Faculty of Medical Sciences, University of Sri Jayewardenepura, Sri Lanka

**Background:** Anemia in the elderly is a common medical problem. Anemia, in any form, has a major impact on quality of life, morbidity, and death in elderly.

**Objective:** To determine the rate, etiological factors of anemia, and the nutritional status with regard to iron intake among elderly individuals (aged over 65 years) attending the Family Practice Centre at the Faculty of Medical Sciences, University of Sri Jayewardenepura.

**Methods & Materials:** A descriptive cross-sectional study was conducted by enrolling 75 elderly individuals (32 females and 43 males). An ethylenediamine tetraacetic acid (EDTA) blood sample was collected from each participant. Hematological data including hemoglobin level, red cell indices and blood picture findings were recorded to determine the etiological category of anemia. Dietary data were collected using an interviewer-administer questionnaire.

**Results:** The rate of anemia among the elders was 29.3% (n=22/75). Cutoff values of hemoglobin for anemia were taken as: male;<13 g/dl and, female;<12 g/dl. The mean hemoglobin level of the anemic elders was 10.7 g/dl (SD=0.83 g/dl) [male=10.4 g/dl (SD=0.88 g/dl), female=11.0 g/dl (SD=0.74g/dl)]. There was no significant difference between the means of hemoglobin level and red cell indices across genders. The majority of anemic individuals [40.9% (n=9)] had mild anemia. Anemia of chronic disease is the commonest etiological category identified (40.9%; n=9) followed by iron deficiency anemia (27.3%; n=6). We were unable to determine the cause of anemia in 4 (18.2%) participants. The majority (96%; n=72) consumed heme-containing food, while all participants consumed green-leafed vegetables. Iron intake was favorable among most of the participants. However, they were less aware of their nutritional status and its effect on anemia.

**Conclusion:** Although, the paucity of data precludes us making a firm conclusion, the rate of anemia among elders in the present study was considerable. Routine hemoglobin monitoring and additional investigations are required to detect the cause of anemia.

## PP 21

### **Knowledge and attitudes towards sexually transmitted diseases among undergraduates of KAATSU International University (KIU), Sri Lanka**

Alwis WLM<sup>1</sup>, Minnath MFS<sup>1</sup>, Gunarathne MGPA<sup>1</sup>, Tharindu VDR<sup>1</sup>, Fernando RMS<sup>1</sup>, Fasmila MFF<sup>1</sup>, Kulathunga KMHH<sup>1\*</sup>, Sampath MKA<sup>2</sup>

<sup>1</sup>Department of Biomedical Science, Faculty of Health Sciences, KAATSU International University (KIU), Sri Lanka, <sup>2</sup>Sri Lanka Institute of Biotechnology- Colombo, Sri Lanka.

**Background:** Sexually transmitted diseases (STDs) remain a major health issue globally. Incident occurrence has increased among young adults and adolescents as they are more vulnerable to sexual risk due to rapid physical, emotional, and social development.

**Objective:** To assess knowledge and attitudes towards sexually transmitted diseases among undergraduates of KIU, Sri Lanka

**Methods & Materials:** A descriptive cross-sectional study was conducted using an online structured, self-administered questionnaire with three sections namely socio-demographic data, knowledge, and attitudes. Three hundred and ninety (n=390) KIU undergraduates were recruited to the study. Data was analyzed using SPSS version 25. Associations between knowledge, attitudes, and socio-demographic factors were determined using Chi-square test. For total knowledge score calculation, a score of less than 90 was considered as poor knowledge level, more than 90 to 106, and 106 to 154 was considered as moderate and good knowledge respectively. In attitude section, below 20 points was considered as poor attitude while 20 to 22, and 22 to 24 was considered as moderate and good level of attitudes respectively (Bloom's cutoff value)

**Results:** The majority of the participants were age 21-25 years (75.4%, n=294). 67.9% (n=265) of them were females. The majority of them (87.4%, n=341) had heard about STDs. Most popular source of information was school (76.9%, n=300). The majority of the female participants (77%, n=103/265) had a good level of knowledge while males showed a moderate level (45.6%, n=57/125). A statistically significant association was observed between knowledge level and the faculties (p=0.014) along with other socio-demographic factors including gender, A/L stream, and current academic year (p=0.001). Females showed a good level (38.9%, n=103) of attitudes while males showed a moderate level (45.6%, n=57). The majority (64.1%, n=250) believed that, banning of prostitution can control the spread while 76.9% (n=300) participants considered using condoms as the best method of protection against STDs. There was no statistically significant association found between attitude level of male and female students or between two faculties (health science and non-health science) (p >0.05).

**Conclusion:** Overall knowledge and attitude towards STDs were at moderate level. Yet it seems to be somewhat controversial, since the students agreed with the statement “STDs are not dangerous because they can be cured”. Therefore, some aspects of knowledge should be further enhanced, and the desirable attitudes must be expanded to improve reproductive health outcomes.

**PP 22**

**Self-care measures on managing coronary artery disease (CAD) and its associated sociodemographic factors among patients with CAD attending the Cardiology Unit, National Hospital Sri Lanka**

Silva NGGH, Perera RASG, Nadeeka PW, Sadamali WAK, Nisansala MWN, Senarath NSASN\*  
*Department of Basic Science, Faculty of Nursing, KAATSU International University (KIU), Sri Lanka.*

**Background:** Coronary-Artery-Disease (CAD) is a cause of major morbidity and mortality worldwide resulting in atherosclerotic plaque formation in the vessel lumen. Prompt identification, treatment, and self-care are vital to improve the survival rate and reduce complications. Self-care measures result in advanced health outcomes by providing the ability to promote health, prevent the progression of the disease, maintain health, and cope with illness and disability.

**Objective:** To assess the self-care measures for managing CAD and its associated sociodemographic factors among patients with CAD

**Methods & Materials:** A descriptive cross-sectional study was conducted among 317 volunteered patients having CAD who attended the Cardiology unit, at National Hospital Sri Lanka. Critically ill patients with psychiatric disorders were excluded from the study. Data were collected using the simple random sampling method and the self-care questionnaire developed by the Institute for Functional Medicine (IFM) in 2016. The questionnaire consisted of 40 items marked on a 6-point Likert scale representing four main domains of self-care (physical, mental, professional, and social well-being). Scoring <3 was considered inadequate self-care in each component. Data were analyzed by descriptive and inferential statistics (Chi-square tests) using SPSS version 25. The ethical approval was granted by the Ethics Review Committee, KIU. The level of significance was considered as  $p < 0.05$ .

**Results:** Mean age ( $\pm$ SD) was 59.08 ( $\pm$ 8.75) years old. The majority were females (60.4%), Sinhalese (88%), married (84.4%), unemployed (50.5%), and belonged to rural and semi-urban areas (57.5%). Except for having family support ( $n=135$ , 49%), more than half of patients reported inadequate self-care (score < 3) for the remaining 39 items of the IFM self-care measure questionnaire on managing CAD. Physical well-being was associated with gender ( $p=0.015$ ), age ( $p < 0.001$ ), religion ( $p=0.003$ ), race ( $p < 0.001$ ), marital status ( $p < 0.001$ ), an education level ( $p < 0.001$ ), and living area ( $p=0.003$ ).

**Conclusion:** Self-care in managing CAD is inadequate among patients with CAD attending the Cardiology unit, NHSL. Strategies need to be taken to improve self-care measures. Health education sessions may be effective and healthcare professionals can play the main role in it.

## PP 23

### **Preference, knowledge, and attitudes towards the companionship during labour: A cross-sectional study among antenatal clinic attendees in Kandy District**

Perera KCN\*, Weerasingha BRGTK

*Department of Nursing, Faculty of Allied Health Sciences, University of Peradeniya, Sri Lanka.*

**Background:** Labour companionship refers to the support provided to a woman during labour and childbirth. Determining preference, knowledge, and attitudes towards labour companionship among pregnant mothers help to inform them about their right to choose and have a companion during labour.

**Objective:** To assess the preference, knowledge, and attitudes towards labour companionship among antenatal clinic attendees in Kandy District.

**Methods & Materials:** A descriptive cross-sectional study was conducted among conveniently sampled 368 pregnant mothers of Gangawatakorale, Doluwa, and Kadugannawa MOH areas in Kandy District. Data were collected using a validated, self-administered, structured questionnaire. Cronbach's alpha of the questionnaire was 0.86. Data analysis was performed using SPSS version 26, and the significance level considered was  $p < 0.05$ . Total knowledge score was categorized as good ( $\geq 75\%$ ), moderate (74–50%), and poor ( $\leq 49\%$ ). Total attitude score was categorized as good (equal or above mean) and poor (below mean). Chi-square test was used to identify the associations between demographic, obstetric characteristics and preference towards labour companionship.

**Results:** The majority of the participants (91.6%) preferred to have a labour companion in their future childbirth. The mean ( $\pm$ SD) knowledge and attitude scores of the participants were 14.28 ( $\pm 5.15$ ), and 64.22 ( $\pm 9.46$ ) respectively. Only 14.1% of the participants had a good level of knowledge and 55.4% of mothers had good attitudes towards labour companionship. Statistically significant associations were found between the preference for labour companionship and age ( $p = 0.01$ ), ethnicity ( $p < 0.001$ ), religion ( $p < 0.001$ ), educational level ( $p < 0.001$ ), gravidity ( $p = 0.004$ ), parity ( $p = 0.049$ ), knowledge ( $p < 0.001$ ), and attitude ( $p < 0.001$ ) towards labour companionship.

**Conclusion:** The preference for labour companionship among mothers was satisfactorily high. The level of knowledge about labour companionship among mothers was found to be unsatisfactory. However, the majority had good attitudes towards labour companionship. Therefore, antenatal mothers' knowledge should be improved via awareness programmes and they should be empowered towards their right to have companionship during labour.

## **PP 24**

### **Facilitators and barriers of participation for continuing professional education among nurses in a selected hospital in Gampaha District, Sri Lanka**

Ranasinghe HRAUN, Damayanthi LC

*Faculty of Allied Health Sciences, University of Sri Jayewardenepura, Sri Lanka.*

**Background:** Continuing Professional Education (CPE) is obtaining professional knowledge and skills in addition to basic education. CPE is most important in nursing practice to provide quality patient care and enhance professional development.

**Objective:** To describe facilitators and barriers for CPE among nurses in a selected hospital in Gampaha District, Sri Lanka.

**Methods & Materials:** A descriptive cross-sectional study was conducted in District General Hospital, Gampaha. Data were collected by using a self-administered questionnaire which was developed by investigator, experts in the field of nursing education and relevant literature findings. The questionnaire was pre- tested among 10 nurses who were not included in the main study. Convenience sampling method was used. Nursing officers who had more than nine months experience were included and those who were on leave were excluded. SPSS version 26 software was used for data analysis and results were presented by using descriptive statistics. Ethical approval was obtained from the Ethics Review Committee Faculty of Medical Sciences, University of Sri Jayewardenepura.

**Results:** The questionnaire was completed by 204 (74.18%) participants. The majority of them were female (n=191, 93.6%). Most of the participants were married (n=191, 93.6%). More importantly, more than half of the total participants (n=117, 57.4%) had involved in the CPE. Short term (< 3days) in-service program was the most common CPE activity that had been participated (mean=1.17, SD=0.820). The results showed that the participants had recognized most common facilitators as delivering quality care (n=188, 92.2%), improving knowledge (n=186, 91.2%), enhancing educational qualifications (n=176, 86.3%), contributing professional development (n=160, 85.3%) and improving skills in clinical practice (n=174, 84.3%). The most common identified barriers were domestic responsibilities (n=176, 86.3%), lack of time available for study (n=172, 84.3%), additional duty shift (n=155,76.0%), cost of courses (n=135, 66.2%), distances of place of CPE activities (n=120, 58.8%), insufficient leave for study (n=119, 58.3%), mode of transport (n=114,55.9%), high number of night duty shift (n=109,53.4%), lack of CPE programs (n=107, 52.5%) and lack of information receiving about CPE (n=103, 50.5%).

**Conclusion:** CPE among the study sample was at a satisfactory level. The results highlight the need for further research to identify factors affecting CPE throughout hospitals in Sri Lanka. Providing rewards, allowing duty leave and flexible duty shifts, making necessary policies, increasing CPE programs and online learning facilities are recommended to improve CPE among nurses.

## PP 25

### **Factors associated with mental health among antenatal mothers attending Castle Street Hospital for Women during the COVID–19 Pandemic**

Tennakoon NMDN, Ruwanthi MDA, Hunukumbura WMIM, Ariyawansha BI, Karunaratne NMRA, Ranaweera RAND\*, Nisansala MWN, Senarath NSASN

*Department of Nursing, Faculty of Nursing, KAATSU International University (KIU), Sri Lanka.*

**Background:** COVID-19 is an emerging infectious disease that has created healthcare challenges worldwide. The series of changes that occurred during pregnancy is the risk of developing COVID-19 related complications. Poor mental well-being increases pregnancy-related negative health outcomes and it may increase the risk of acceleration of COVID-19 related complications.

**Objective:** To assess the level of mental health and its associated factors among antenatal mothers attending Castle Street Hospital for Women during the COVID–19 pandemic.

**Methods & Materials:** A descriptive-cross-sectional study was conducted among 250 pregnant women attending Castle Street Hospital for Women from May to August 2022. Data was collected from volunteer pregnant women admitted to hospital and a simple random sampling method was used. A pre-tested questionnaire consisting of the Patient Health Questionnaire (PHQ-9) and the Generalized Anxiety Disorder scale (GAD -7) was used to assess mental health. Data was analyzed by descriptive and inferential statistics using SPSS version 25. Ethical approval was obtained by the Ethics Review Committee, KIU.

**Results:** Participant’s’ age ranged from 19-47 years old and the mean age was 30.09±5.73 years old. Mean income level was 78992 ± 46987 LKR. The majority were Buddhists (70%), married (98.8%), employed (62%), and educated above the GCE O/L examination (82.8%). Among respondents, 46.8% represented the third trimester of pregnancy, and 22% represented pregnancy-related complications. The majority (92.4%) were vaccinated against COVID-19 and 93.6% always used face masks in public places. The majority reported a moderate level of symptoms of depression (98.8%, n=247), and anxiety (94.8%) (Moderate to severe depression - 1.2%, mild anxiety – 1.2%, severe anxiety - 4%). The level of anxiety was not associated with wearing a mask (p=0.323), vaccination against COVID-19 (p=0.890), gravida (p=0.329), parity (p=0.428), pregnancy-related complications (p=0.543), and level of education (p=0.677) However, level of anxiety was associated with the monthly income (p=0.038), and age category (p=0.006).

**Conclusion:** The level of income and age category was associated with the level of anxiety. Periodical surveys are vital to assess the mental health, and strategies need to be taken to reduce the level of anxiety and depression during pregnancy. Health education sessions may be useful and healthcare workers can play a main role on that.

**PP 26**

**Knowledge and attitudes towards usage of face masks during COVID-19 pandemic among nursing students, Faculty of Allied Health Sciences, University of Peradeniya: A descriptive cross-sectional study**

Nishshanka NMDC<sup>1\*</sup>, Kumarasiri PVR<sup>2</sup>, Weerasingha BRGTK<sup>1</sup>

<sup>1</sup>Department of Nursing, Faculty of Allied Health Sciences, University of Peradeniya, Sri Lanka, <sup>2</sup>Department of Community Medicine, Faculty of Medicine, University of Peradeniya, Sri Lanka.

**Background:** Wearing a face mask is important to prevent transmission of respiratory tract infections including COVID-19. A face mask is effective when it is used properly. Nursing students play a significant role as health educators in the community. Therefore, it is important to evaluate their level of knowledge and attitudes regarding the usage of face mask during COVID-19 pandemic.

**Objective:** To assess the knowledge and attitudes towards usage of face masks during COVID-19 pandemic among nursing students, Faculty of Allied Health Sciences, University of Peradeniya.

**Methods & Materials:** A descriptive cross-sectional study was conducted from July to October 2022 among 178 nursing students in the Faculty of Allied Health Sciences, University of Peradeniya. A convenience sampling technique was used and all the nursing students who fulfilled the inclusion criteria were recruited for the study. A pre-designed, pre-tested, self-administered, structured questionnaire including demographic data, knowledge and attitude related questions was used to collect data. Data analysis was performed using the standard statistical tests available in the SPSS version 26 and the significance level was 0.05.

**Results:** Mean overall knowledge and attitude scores of the participants were  $19.03 \pm 2.65$  and  $68.10 \pm 6.93$ , respectively. Only 50.6% had a good knowledge towards the usage face mask and only 52.2% students had positive attitudes towards usage of face mask. Statistically significant associations were found between knowledge level and academic year ( $p=0.028$ ) and duration of clinical exposure ( $p=0.028$ ). Attitude towards face mask use was significantly associated with the number of awareness/training programmes attended on COVID-19 ( $p=0.035$ ).

**Conclusion:** The majority of nursing students had poor knowledge and negative attitudes towards usage of face mask during COVID-19 pandemic. Therefore, nursing students' knowledge and attitudes towards usage of face mask during COVID-19 pandemic should be improved via awareness programmes emphasizing its importance.

**PP 27**

## **Knowledge, practices and perceived barriers regarding patient education on inhaler use among nurses working in a tertiary care hospital, Western Province, Sri Lanka**

Liyanaarachchi PLDS<sup>1\*</sup>, Abeyratne RMTB<sup>2</sup>

<sup>1</sup>National Hospital of Sri Lanka, Sri Lanka, <sup>2</sup> Department of Nursing and Midwifery, Faculty of Allied Health Sciences, University of Sri Jayewardenepura, Sri Lanka.

**Background:** Chronic respiratory diseases (CRDs) are illnesses that affect the lungs and airways. As it distributes medication directly to the respiratory system with a higher local concentration and no systemic effect, inhaled drugs are thought to be the most effective method. For inhaled medication to work better, correct inhaler technique is crucial. The healthcare provider who instructs and assesses patients' inhaler technique is nurse.

**Objective:** To describe the knowledge, practices and perceived barriers regarding patient education on inhaler use among nurses working in a tertiary care hospital, Western Province, Sri Lanka.

**Methods & Materials:** A cross-sectional study with a proportionate sample of 342 staff nurses of National Hospital of Sri Lanka was carried out. A pre tested, self-administered questionnaire was used to collect data. Questions on socio-demographic data, knowledge on inhaler technique and maintenance of inhaler device, Nurses' practice on inhaler education, and barriers to perform inhaler education were included in the questionnaire. Data were analysed with SPSS version 26. Descriptive analysis was done and associations were examined using Chi-square test. Significance level was set at  $p < 0.05$ .

**Results:** The majority of participants (65.5%) were aged between 22 to 32 years. Nearly half (43.6%) of participants had work experience of 1 to 5 years, and 94.7% of them were females. The mean knowledge score was 7.24 ( $\pm 2.20$ ). Of the sample only 40.6% had good knowledge. Age ( $p < 0.001$ ), marital status ( $p = 0.007$ ), working experience ( $p < 0.001$ ), and education level ( $p = 0.001$ ) were associated with the knowledge. The majority of participants perform patient education on inhaler use when inhaler medicine is prescribed. Frequently used topics on patient education for inhaler use were, 'steps of inhaler technique' and 'importance of inhaler medication'. The most popular technique of education was demonstration. Identified major barriers were lack of time (69.8%) and language barriers (61.8%).

**Conclusion:** Knowledge regarding the use of inhaler was inadequate. However, nurses are willing to improve their knowledge by attending in- service programmes.

## PP 28

### **Factors associated with self-care agency in patients with coronary heart disease following percutaneous coronary intervention at Teaching Hospital, Kalutara**

Senevirathne PM<sup>1</sup>, Bennet UGNL<sup>1</sup>, Amarasinghe PDHR<sup>1</sup>, Sandamali MN<sup>1</sup>, Yapa HE<sup>2\*</sup>

<sup>1</sup>Teaching Hospital, Kalutara, Sri Lanka, <sup>2</sup>Department of Nursing, The Open University of Sri Lanka.

**Background:** Self-care agency is the individual’s capabilities to initiate and perform health activities in order to maintain one’s life and health. Following percutaneous coronary intervention, patients with coronary heart disease needs to undertake self-care activities to uplift their wellbeing.

**Objective:** This study was aimed to investigate factors associated with self-care agency in patients with coronary heart disease following percutaneous coronary intervention at Teaching Hospital, Kalutara.

**Methods & Materials:** A descriptive cross-sectional study was conducted at the cardiology clinic of the Teaching Hospital, Kalutara. A total of 271 adults with coronary heart disease and more than one month post percutaneous coronary intervention were conveniently recruited to the study. A validated self-administered 15-items revised appraisal of self-care agency scale (A higher score indicate greater level of self-care agency) along with socio-demographic questionnaire was used to collect data. Data were analysed using descriptive statistics and multiple linear regression.

**Results:** The mean age of participants was 56.46±10.21 years with the majority being men (63.1%). Approximately, 64% of participants were educated up to ordinary level. More than half of participants had at least one comorbidity (62.6%). Nearly half of the participants (46.2%) were unemployed. Most participants had greater level of self-care agency (mean: 51.21±6.92; range: 28-68). Greater levels of self-care agency were significantly associated with younger age (<50 years; p=0.007), Christian religion (p=0.001), educated beyond ordinary level (p=0.003), being professionals (p<0.001) and having greater number of family members in the household (>4 members; p<0.001).

**Conclusion:** Self-care agency among patients with coronary heart disease following percutaneous coronary intervention is satisfactory. Identification of multiple factors associated with self-care agency prompts nurses to recognize those who experience difficulties in performing self-care early, and design interventions to support people to undertake self-care activities so that their wellbeing can be improved.

## PP 29

### **Invitro quality and stability assessment of furosemide 40 mg tablets available in Karapitiya, Galle, Sri Lanka**

Anuruddhika KPII\*, Jayasinghe M, Subasinghe HWAS, Wijesekara K

*Department of Pharmacy, Faculty of Allied Health Sciences, University of Ruhuna, Sri Lanka.*

**Background:** Different formulations of the same medicine can vary in quality and stability under different storage conditions.

**Objective:** This study evaluated the quality and stability of furosemide 40 mg tablets marketed in Karapitiya suburb.

**Methods & Materials:** Three furosemide 40 mg tablet (two generics and one branded generic) were obtained from private and government healthcare facilities in Karapitiya. From each product, 350 tablets were purchased from one batch number. Samples were stored for 30 days in the same packaging material as they were dispensed. The temperature at the sample collection site and recommended storage temperature per label were recorded. Baseline analysis ( $T_0$ ) and stability after one month ( $T_1$ ) were performed following BP/IP standards. The stability was tested under home ( $T_{1N}$ ) and recommended ( $T_{1R}$ ) storage conditions.  $T_{1N}$  simulated the temperature and humidity (27°C-46°C, RH 33%-88%) in a tropical room, and  $T_{1R}$  simulated the manufacturer's recommendation (20°C-25°C, RH 57%-65%). Test results were compared using the independent T-test.

**Results:** All samples tested at  $T_0$  complied with official limits of quality parameters except the hardness test (Only branded generic drug passed the hardness test). At  $T_{1R}$  analysis, all samples complied with official limits of quality parameters except hardness test (<40 N). At  $T_{1N}$  analysis, all samples satisfied the acceptance limits of weight variation (<7.5%), disintegration (<15 min), and dissolution ( $Q > 80\%$  at 45 min) tests except hardness (<40 N), friability (>1%), and assay (<95%). Generic samples dispensed in polythene packages exhibit discoloration under home storage conditions. Results were compared to  $T_0$  analysis, each test result showed a significant difference under home storage conditions, but only the weight variation, hardness, and dissolution tests showed a significant difference under recommended environmental conditions ( $p < 0.001$ ).

**Conclusion:** The quality and stability of furosemide tablets were negatively impacted by the extreme temperature and humidity fluctuations in home storage. Tablets stored under manufacturer's recommended conditions remained stable for 30 days.

**Acknowledgment:** This study was funded by the research grant/2021 of the Faculty of Allied Health Sciences, University of Ruhuna.

## PP 30

### **Repackaging propranolol tablets in plastic bags: Stability under different storage conditions**

Madhushika IWH\*, Jayasinghe M, Wijesekara KAKD, Subasinghe HWAS

*Department of Pharmacy, Faculty of Allied Health Sciences, University of Ruhuna, Sri Lanka.*

**Background:** Repackaging comprises removing pharmaceuticals from the original packaging and placing them in alternative packaging material. These packaging materials may not provide the same level of stability as the original packaging in different storage conditions.

**Objective:** To assess the stability of propranolol tablets repackaged in plastic dispensing bags.

**Methods & Materials:** A sample of 1000 propranolol hydrochloride 40 mg BP tablets with the same lot number was purchased from a semi-government pharmacy. After 30 days of storage at both manufacturer-recommended storage conditions (20.0 °C - 26.2 °C; RH 57% - 64%) and home storage conditions (27.3 °C - 46.5 °C; RH 50% - 79%), the physical and chemical stability of the propranolol tablets, repackaged in plastic dispensing bags was assessed as per the British Pharmacopoeia 2020 specifications. Data were analyzed using IBM SPSS version 25 software and  $p < 0.05$  was considered statistically significant.

**Results:** Propranolol tablets repackaged in plastic dispensing bags for 30 days confirmed chemical and physical stability by assay, weight uniformity, friability, and disintegration tests according to the BP 2020 specifications. However, there was a significant difference in the mean (SD) tablet weight ( $175.49 \pm 1.82$  vs  $173.91 \pm 2.06$ ,  $p = 0.014$ ), disintegration time ( $2.35 \pm 0.021$  vs  $3.07 \pm 0.021$ ,  $p < 0.001$ ), and propranolol hydrochloride content ( $96.76 \pm 0.51$  vs  $101.09 \pm 0.21$ ,  $p < 0.001$ ) between propranolol tablets stored in the home and manufacturer recommended storage conditions in plastic dispensing bags. Tablets repackaged in plastic dispensing bags and stored in home conditions showed discoloration of tablet surfaces after 7 days of storage.

**Conclusion:** Propranolol tablets repackaged in plastic dispensing bags are more stable in manufacturer-recommended storage conditions than in home storage conditions. Therefore, it is essential to counsel patients to store repackaged propranolol tablets in plastic dispensing bags under the proper storage condition recommended by the manufacturer.

**Acknowledgment:** This study was funded by the research grant/2021 of the Faculty of Allied Health Sciences, University of Ruhuna.

**PP 31**

**Perception towards storage, disposal and misuse of unused and expired pharmaceuticals in households amongst the staff working at Dhakshinapaya Ministry Complex, Labuduwa, Galle**

Chandrasena NKPG<sup>1</sup>, Karunanayaka KDSV<sup>1\*</sup>, Gunawardena S<sup>2</sup>

<sup>1</sup>Department of Pharmacy, Faculty of Allied Health Sciences, University of Ruhuna, Galle, Sri Lanka, <sup>2</sup>Department of Physiology, Faculty of Medicine, University of Ruhuna, Galle, Sri Lanka.

**Background:** In many underdeveloped countries, pharmaceutical waste has been generally neglected even when they have a high impact on human beings, the environment, and the health economy of a country.

**Objective:** To find out the current perception of storage, disposal and misuse of pharmaceutical waste among households in Galle, Sri Lanka.

**Methods & Materials:** This was a qualitative study performed using in-depth interviews via a semi-structured questionnaire conducted on staff at Dakshinapaya Ministry Complex, Galle. Data were collected until no new information was obtained and participants were recruited by snowball sampling technique involving the volunteers of staff members. Thematic analysis was used to analyze the data.

**Results:** Of the 40 participants, 11 (27.5%) were males and 29 (72.5%) were females. Based on the in-depth interviews, the following theme was identified; “the current perception towards storage, disposal, and misuse of pharmaceutical waste”. Under the theme, sub-themes were developed and they revealed that the participants had a comprehension of the high risk of keeping expired medicines at home. In spite of that, all participants had no reasonable idea that disposal by burning, flushing down the toilet, disposal to sink, burying, and throwing household garbage are harmful to the environment or wild animals. As a significant finding, most participants didn’t believe that the reuse of unused medications had a risk to human health. Almost all participants agreed that there was inadequate information among household members and emphasized the necessity for some form of pharmaceutical waste management.

**Conclusion:** There was a poor perception on unsafe disposal methods, their hazardous effect on the environment and the reuse of leftover medicines among the general public. Therefore, the community will be highly benefitted by implementing awareness programs and a proper waste management system like a drug take-back system for handling unused and expired pharmaceuticals.

## PP 32

### **Analysis of in-vitro antioxidant properties of green synthesized Ni/reduced graphene oxide composite**

Gamage HMGMP<sup>1</sup>, Madushani WSAT<sup>1</sup>, Pahalagedara MN<sup>2\*</sup>

<sup>1</sup>Department of Medical Laboratory Sciences, Faculty of Allied Health Sciences, University of Sri Jayewardenepura, Sri Lanka, <sup>2</sup>Department of Basic Sciences, Faculty of Allied Health Sciences, University of Sri Jayewardenepura, Sri Lanka.

**Background:** Nickel nanoparticles (NiNPs) possess numerous benefits useful in biomedical applications. Synthesis of NPs via green approaches has become prominent due to their cost effective, eco-friendly manner. Reduced graphene oxide (rGO) was used as the support to disperse and stabilize NPs while preventing agglomeration.

**Objective:** Synthesis of Ni/rGO nanocomposites via green approach and assessing their in-vitro antioxidant activity.

**Methods & Materials:** Azadirachta indica (Neem) extract was used as the reducing and capping agent. Neem/NiNPs were prepared by heating ethanolic Neem leaf extract and NiCl<sub>2</sub> at 600°C for 24 hours. Different Ni/rGO nanocomposites were synthesized using ethanolic Neem extract, sonicated GO and NiCl<sub>2</sub>. Ni/rGO (RT) was prepared at room temperature, Ni/rGO (heated) was prepared at 600C, and Ni/rGO (sonicated) was prepared by sonicating the mixture at 600°C. Then, mixtures were centrifuged, washed with ethanol, and was dried at 60°C. Nanocomposites were characterized with UV-Visible spectroscopy, Thermogravimetric Analysis (TGA), Scanning Electron Microscopy (SEM), Energy Dispersive X-Ray analysis (EDX), and Fourier-Transform Infrared Spectroscopy (FTIR). Antioxidant properties were evaluated using 2, 2-diphenyl-1-picrylhydrazyl (DPPH) assay at 517nm, using ascorbic acid as positive control.

**Results:** UV, SEM-EDX and FTIR results confirmed successful formation of Ni/rGO nanocomposites. All composites possessed concentration dependent antioxidant activity and activity was always greater than rGO. Highest activity was shown by Neem/NiNPs where inhibition was 78% for a 250 ug/ml sample. EDX shows signals of Ni, oxygen and carbon confirming incorporation of NiNPs into composite. Among composites, highest activity was shown by Ni/rGO (RT) where inhibition was 63% and EC<sub>50</sub> was 35ug/ml. This contained only 17 weight% Ni. These results confirm that, even a lower amount of NiNPs show considerably high activity due to the formation of mono-dispersed layer of NPs and phytochemicals attached on rGO.

**Conclusion:** Antioxidant activity had greatly enhanced due to synergetic effects between NiNPs and rGO. This suggests that Neem extract can be extensively used in green production of Ni/rGO composite which is an excellent candidate for safe biomedical, pharmaceutical as well as other industrial applications.

**PP 33**

**Determination of the knowledge on rational usage of oral anticoagulant among patients attending to Cardiology Clinic at Teaching Hospital Jaffna**

**Ijasa Ibrahim<sup>1\*</sup>, Paramanathan Kalki<sup>1</sup>, Rajendran Surenthirakumaran<sup>2</sup>, Mahesan Guruparan<sup>3</sup>**

<sup>1</sup>Department of Pharmacy, Faculty of Allied Health Sciences, University of Jaffna, Sri Lanka, <sup>2</sup>Faculty of Medicine, University of Jaffna, Sri Lanka, <sup>3</sup>Teaching Hospital, Jaffna, Sri Lanka.

**Background:** Thrombosis is a common condition in patients with thromboembolic and cardiac diseases. Warfarin has been the mainstay oral anticoagulant agent for the last several decades. Since it's a narrow therapeutic index medicine, it requires proper usage in outpatient setting with prolonged treatment. Knowledge on rational usage of warfarin can prevent insufficient therapeutic outcome, adverse drug reactions and improving the quality of life.

**Objective:** To determine the knowledge regarding the rational usage of oral anticoagulant among patients attending cardiology clinic at Teaching Hospital Jaffna.

**Method & Materials:** This was a hospital based cross-sectional study. Data were collected by using pre designed an interview administrated questionnaire from 18<sup>th</sup> June 2019 to 18<sup>th</sup> of July 2019. Nearly all the patients who are attending to the clinic were included in this study. Data were processed using SPSS. The knowledge part of the questionnaire contains four different categories of questions and each correct response was scored with one mark while incorrect response was received zero mark. Total of twenty six marks was given for this part in the questionnaire. The score from 14 to 26 was considered as good knowledge and score from 0 to 13 was considered as poor knowledge.

**Results:** Totally 337 participants were included in this study. The majority (58.5%) had good knowledge and 41.5% had poor knowledge on rational usage of oral anticoagulant. The majority of the participants (84.6%) had knowledge on warfarin-meal time interval. Of the sample, (80.7%) were had inadequate knowledge on INR monitoring.

**Conclusion:** This study demonstrated most of the participants (58.5%) had good knowledge on rational usage of oral anticoagulant.

**PP 34**

**Non-steroidal anti-inflammatory drug use in elderly patients: A hospital based cross-sectional study**

Malika WI\*, De Silva KIM, Subasinghe HWAS

*Department of Pharmacy, Faculty of Allied Health Sciences, University of Ruhuna, Sri Lanka.*

**Background:** Long-term use of Non-Steroidal Anti-Inflammatory drugs (NSAIDs) is common in treatment of inflammatory diseases, pain associated with musculoskeletal conditions, and prevention of cardiovascular diseases.

**Objective:** This study aimed to evaluate NSAIDs usage among elderly patients attending outdoor pharmacy of Teaching Hospital, Karapitiya.

**Methods & Materials:** A descriptive cross-sectional study was conducted among elderly patients over 60 years who were attending routine clinic visits and taking NSAIDs from the outdoor pharmacy at least in the last one month. Study sample (n=317) was selected using a convenience sampling method. Data were collected using a validated and pre-tested interviewer-administered questionnaire on socio-demographic and NSAID usage pattern. Data were analyzed using SPSS version 25 and Microsoft Excel 2013.

**Results:** Mean (SD) age of the study participants was 68.4 (6.5) years, age range was 60-94 years, and 60.3% were between 60-69 years. Of the sample, 55.2% (n=175) were females. Prevalence of NSAID usage in elderly patients was 59.3%. Low dose aspirin (58.7%), diclofenac (32.2%), celecoxib (12.9%), ibuprofen (0.6%), and indomethacin (0.3%) were the commonly used NSAIDs by study participants. Among them, low-dose aspirin was the most frequently prescribed NSAID (58.7%). The majority of participants (83.3%) were prescribed NSAIDs for regular use. The median (IQR) treatment duration of NSAID was 6 years (3-10 years). Of the participants, 95.6% were using a single NSAID, and 88% were on non-selective NSAIDs. The main indications of NSAIDs were cardiovascular diseases (55.5%), and joint pains (25.8%). Over the counter (OTC) usage of NSAIDs was identified in 7.6% of participants. NSAIDs used as OTC medications were diclofenac sodium tablet (20.3%), diclofenac gel (15.6%), and ibuprofen (1.6%). Most frequent indication for OTC use of NSAIDs was knee joint pain (37.5%).

**Conclusion:** The majority of elderly patients used NSAIDs on a regular basis for longer periods with a prescription or as OTC medicines. Non-selective NSAID usage was more prominent than selective COX-2 inhibitors. The common indication for OTC use of NSAIDs among elderly patients was joint pains.

## PP 35

### **Irregular medication use among geriatric patients with chronic diseases: A hospital based cross sectional study**

Tharangani AR\*, De Silva KIM, Subasinghe HWAS

*Department of Pharmacy, Faculty of Allied Health Sciences, University of Ruhuna, Sri Lanka.*

**Background:** Geriatric patients are more likely to have chronic diseases that necessitate sophisticated pharmacological therapy including multiple medications. Irregular use of medications and less compliance are not unusual among patients who use multiple medication regimens.

**Objective:** This study aimed to assess the erratic medication use and factors related to it among geriatric patients with chronic diseases in Teaching Hospital, Karapitiya.

**Methods & Materials:** A descriptive cross-sectional study was conducted among medical clinic attendees who were in the age of 65 years or above, and on treatment for diagnosed chronic diseases for more than six months. A total of 308 patients were selected using a convenience sampling method. An interviewer-administered questionnaire, validated by two healthcare expertise was utilized to collect data on socio-demographics, medical history, medication using pattern and reasons for irregular medicine use. Data were analyzed using SPSS version 25.

**Results:** The mean (SD) age of the study participants was 74.30 (6.95) years, and 62% were women. Of the sample, 73.5 % showed irregular medication use one week prior to the data collection date. Approximately 16% (n=49) had missed at least one of the prescribed medicines while 28% (n=85) and 24.7% (n=76) of patients, had not taken medicines in the recommended doses and frequencies respectively. Nearly 44% (n=135) stated that they stopped taking their medicines without prior advice from their doctor. High cost (36.7%), difficulty in remembering medication administration time (36.7%), difficulty in remembering all the doses (35.7%), physical disabilities (30.5%), and forgetting to take prescribed medicines (56%) were the main reasons for erratic use of medications.

**Conclusion:** Irregular medication use is common among geriatric patients with chronic diseases. The cost of medications, forgetfulness, and physical disabilities were main reasons related to it. Educating patients and caregivers regarding their medications and increase social support will be beneficial for geriatric patients to improve medication use.

**PP 36**

**Relationship between PT/INR and APTT in patients on warfarin: A study at a tertiary care teaching hospital.**

Attanayake MASM<sup>1</sup>, Manathunga ID<sup>1\*</sup>, Kulathilake HWCK<sup>2</sup>

<sup>1</sup>Department of Medical Laboratory Sciences, Faculty of Medical Sciences, University of Sri Jayewardenepura, Sri Lanka,

<sup>2</sup>Department of Pathology, Faculty of Medical Sciences, University of Sri Jayewardenepura, Sri Lanka.

**Background:** Warfarin prolongs coagulation by inhibiting the synthesis of biologically active forms of coagulation factors and regulatory factors, which are dependent on vitamin K. The Prothrombin Time (PT) and International Normalized Ratio (INR) are routinely used to monitor warfarin therapy in clinical settings. In addition to PT, APTT is also prolonged by warfarin therapy due to the effect of warfarin on the intrinsic pathway.

**Objective:** In this study, we aimed to evaluate the distributions of levels of PT/INR and APTT and the relationship between INR and APTT in a cohort of patients on long-term warfarin.

**Methods & Materials:** Seventy four (n=74) patients on long-term (at least six months) warfarin therapy were recruited from the University Haematology clinic of Colombo South Teaching Hospital. PT and APTT were performed in the routine citrated blood sample during their regular clinic visit using a semi-automated 4-channel CA-104 analyzer. Data were analyzed statistically by using SPSS.

**Results:** Among the recruited 74 patients, 36 were females and 38 were males. In this cohort, PT and PT/INR were normally distributed ( $p=0.196$ ,  $p=0.193$  respectively). The distribution pattern of APTT deviated from the normal standard pattern due to some exceptional cases of females. There was no significant correlation between INR and warfarin dose. The majority of patients (72.5%) who had INR below the mean INR (2.5) had shown APTT less than the mean APTT (39.18s) in this cohort. The majority of patients (82.3%) who had INR above the mean INR had shown APTT higher than the mean APTT. Statistical results of the study established that there was a good (strongly positive) linear correlation between the APTT and INR since the Pearson correlation coefficient was equal to 0.799 ( $p<0.001$ ).

**Conclusion:** Our study concluded that in addition to the elevation of PT/INR and APTT by warfarin, there is a good linear correlation between the elevation of APTT and INR.

PP 37

**Formulation and *invitro* evaluation of an antibacterial cream with *Nyctanthes arbor-tristis* L. flower extract**

Silva MAH<sup>1</sup>, Siriwardhene MA<sup>2</sup>, Karunanayaka KDSV<sup>1</sup>, Yasarathna KWGKP<sup>1\*</sup>

<sup>1</sup>Department of Pharmacy, Faculty of Allied Health Sciences, University of Ruhuna, Sri Lanka, <sup>2</sup>Department of Pharmacy and Pharmaceutical Sciences, Faculty of Allied Health Sciences, University of Sri Jayewardenepura, Sri Lanka.

**Background:** Presence of secondary metabolites in medicinal plants offers an exciting avenue for new drug discovery and development. *Nyctanthes arbor-tristis* L. (Sepalika) is well known because of its pharmacological properties like antibacterial, antifungal, anti-ulcer, analgesic, anti-inflammatory, anti-viral, hypoglycemic, and anti-cancer activity.

**Objective:** The aims of this study were to formulate an herbal cream derived from flower extract of *Nyctanthes arbor-tristis*, and to perform *in-vitro* evaluation of its antibacterial property.

**Methods & Materials:** Ethyl acetate flower extract of *Nyctanthes arbor-tristis* was used. Qualitative phytochemical screening was conducted using different tests. Folin-Ciocalteu colorimetric method and aluminium chloride colorimetric method were used to determine the total phenolic and total flavonoid contents respectively. Four different cream bases were prepared and three different creams were formulated by changing the weight percentage of the flower extract using the most stable cream base. Agar well diffusion assay was conducted to determine the antibacterial activity of both crude extract and creams using co-amoxiclav and neomycin cream as positive controls. Stability of creams was observed over 21 days in room temperature and 2-8°C.

**Results:** From qualitative phytochemical analysis, the presence of phenols, flavonoids, diterpenes, tannins, carbohydrates, glycosides and phytosterols was evident. Total phenolic and total flavonoid contents were 84.12 mg gallic acid equivalents per gram of dry weight and 145.94 quercetin equivalent per gram of dry weight respectively. The crude extract (20 mg/ml) showed 10.00 mm, 10.83 mm and 11.50 mm zones of inhibition against *S. aureus*, *E. coli*, and *P. aeruginosa* respectively. The cream with 0.1% (w/w) of flower extract showed 10.00 mm, 10.16 mm, and 11.00 mm zones of inhibition against *S. aureus*, *E. coli*, and *P. aeruginosa* respectively.

**Conclusion:** The herbal cream with 0.1% (w/w) of the flower extract showed a higher antibacterial activity being active against all three microorganisms tested compared to other cream formulations.

## PP 38

### **Designing and validation of patient information leaflet for pediatric amoxicillin powder for oral suspension**

Sandesh JT\*, Dissanayake GDC, Prasadi GAM

*Department of Pharmacy, Faculty of Allied Health Sciences, University of Ruhuna, Sri Lanka.*

**Background:** Antibiotic suspensions are the preferred dosage form for the treatment of bacterial infections in pediatric patients. Due to the inadequate handling and preparation knowledge of patients, antibiotic suspensions are used incorrectly. Print materials with illustrations can be helpful to memorize instructions on preparation, handling, and administration.

**Objective:** To design and validate the illustrated Patient Information Leaflet for pediatric amoxicillin powder for oral suspension.

**Methods & Materials:** An illustrated Patient Information Leaflet (PIL) was created, and the rest of the study was carried out in three phases. Ensuring Quality Information for Patients (EQIP) tool and criteria to assess the design of the PIL were administered to an expert panel of six via E-mail survey for validation. PIL was updated in response to suggestions. In the second step, readability was validated by presenting a user-testing questionnaire with PIL to 20 caregivers of pediatric patients aged 1 to 5 years. As the 3<sup>rd</sup> phase, same user-testing questionnaire was administered to randomly selected 60 caregivers as pre and post-test with PIL as the intervention and then user-opinion test was performed.

**Results:** In the first phase, mean quality score ( $\pm$ SD) 60.9% ( $\pm$ 11.0%) according to the EQIP tool and the mean score design of the PIL was 19.5% ( $\pm$ 6.0%). In the second phase, PIL was validated for readability with the mean score ( $\pm$ SD) of 97.0% ( $\pm$ 6.3%) ensuring overall results of 80% and above 80% for each question correctly. The overall user-testing readability mean scores ( $\pm$ SD) had significantly improved from 46.8% ( $\pm$ 9.3%) to 99.2% ( $\pm$ 2.8%) ( $p < 0.001$ ) due to the intervention. In user-opinion test, the mean user-opinion score ( $\pm$ SD) was 17.9% ( $\pm$ 2.1%).

**Conclusion:** The illustrated PIL for pediatric amoxicillin for oral suspension has shown positive impact on the improvement of knowledge in caregivers regarding reconstitution, post-reconstitution storage, and usage. In addition, the PIL comprised with good content, design and layout, and greater acceptability.

## PP 39

### ***Invitro* evaluation of radical scavenging activity of extracts of *Pterocarpus marsupium* (Gammalu) bark**

Nawarathna TPH\*, Hettihewa SK, Dissanayake AS

Department of Pharmacy, Faculty of Allied Health Sciences, University of Ruhuna, Sri Lanka.

**Background:** The use of *Pterocarpus marsupium* in the Ayurveda system and Sri Lankan traditional medicine is many years old. The gum resin and the aerial parts of the tree that includes bark, heartwood, flowers, and leaves are most commonly used.

**Objective:** To evaluate the total phenolic content, total flavonoid content, and *in-vitro* antioxidant activity of water and 80% aqueous methanol extracts obtained from the bark of *Pterocarpus marsupium*.

**Methods & Materials:** Oven-dried powdered bark of *Pterocarpus marsupium* was extracted with water and 80% aqueous methanol at room temperature by incubating on a laboratory shaker. The preliminary phytochemical tests were carried out for both extracts separately. The total phenolic content and total flavonoid content were assessed using the Folin-Ciocalteu method and the aluminium chloride colorimetry method, respectively. *In-vitro* radical scavenging activity was evaluated using 2,2-diphenyl-picrylhydrazyl (DPPH) assay. Data were analyzed using one-way ANOVA at 5% significance level.

**Results:** The quantitative analysis for phenolics in 80% aq. methanol and water extracts were found to be  $3211.35 \pm 54.41$  mg GAE (Gallic Acid Equivalent)/100 g dry weight (DW) of bark and  $2204.68 \pm 135.92$  mg GAE/100 g DW of bark, respectively. The total flavonoid content of the 80% aq. methanol extract and water extract were found to be  $1385.41 \pm 83.62$  mg CAE (Catechin Equivalent)/100 g DW of bark and  $687.57 \pm 83.73$  mg CAE/100 g DW of bark, respectively. The radical scavenging activity of the two extracts were found to be  $26.07 \pm 0.91$  mmol TE/100 g DW of bark for 80% aq. methanol extract and  $16.39 \pm 0.89$  mmol TE/100 g DW of bark for water extract. The qualitative analysis showed that both extracts contained phenolics, flavonoids, alkaloids, tannins, saponins, carbohydrates, and reducing sugars.

**Conclusion:** The 80% aq. methanol extract from bark of *Pterocarpus marsupium* exhibited significantly high values of total phenolic content ( $p=0.000$ ), total flavonoid content ( $p=0.000$ ), and radical scavenging activity ( $p=0.000$ ).

**PP 40**

**Customer satisfaction towards pharmaceutical care provided by the community pharmacies in selected MOH areas, Galle District, Sri Lanka**

Dissanayake GDC\*, Sandesh JT, Prasadi GAM

*Department of Pharmacy, Faculty of Allied Health Sciences, University of Ruhuna, Sri Lanka.*

**Background:** Understanding customer expectations and actual experiences is necessary to assess satisfaction, which is an important indicator of the quality of healthcare services.

**Objective:** To assess customer satisfaction towards the pharmaceutical care provided by the community pharmacies in selected MOH areas, Galle District, Sri Lanka.

**Methods & Materials:** A descriptive cross sectional study was conducted in ten randomly selected community pharmacies, five each from Galle Municipal Council and Bope-Poddala MOH areas. Ethical approval was obtained from Ethics Review Committee, Faculty of Allied Health Sciences, University of Ruhuna. Sample size was 386. Participants were selected using stratified random sampling based on the population of MOH areas. Customers above the age of 18 years who visited pharmacies with a valid prescription were included, except the customers related to health sector. Customers were given a self-administered questionnaire adopted from a pre-validated questionnaire to collect data on their expectations and experiences by rating on a 5-point Likert scale based on three domains; developing a relationship with customer, assessing patients, clarifying the role of medications. Satisfaction was assessed by taking the difference in values of experience and expectation.

**Results:** Expectations of the customers from the pharmacy and actual experiences they received from the pharmacy was significantly different ( $p < 0.001$ ). Values for customer expectations were higher than the experiences of the customers. Customers showed highest expectations in clarifying the role of medications. The majority (84.7%) of the customers were unsatisfied with the pharmaceutical care of the community pharmacies. Presence of the pharmacist ( $p < 0.001$ ) and number of staff members ( $p < 0.001$ ) in the pharmacy were significantly associated with the customers' satisfaction.

**Conclusion:** Given that customers' expectations were higher than what they experienced, understanding the real customers' need will improve the pharmacy services and customer satisfaction. Dissatisfaction of the majority of the customers emphasized the importance of good community pharmacy staff training programs.

## **PP 41**

### **Assessment of prices, packaging, and quality of paracetamol tablets dispensed by public and private sector pharmacies in Karapitiya**

Pramodika MAG\*, Jayasinghe M, Subasinghe HWAS, Wijesekara K

*Department of Pharmacy, Faculty of Allied Health Sciences, University of Ruhuna, Sri Lanka.*

**Background:** Differently priced brand and generic versions of paracetamol tablets are available in the market. Knowledge of post-marketing pharmaceutical quality could help promote generic substitution.

**Objective:** This research examined the prices, primary packaging, and quality of paracetamol 500 mg tablets marketed in the Karapitiya suburb of Galle.

**Methods & Materials:** A hospital, *Rajya Osu-sala* pharmacy, and two community pharmacies in Karapitiya were conveniently selected for the sample collection. The samples were collected depending on the availability of paracetamol tablets at the sample collection site. The price and the type of packaging were recorded during the sample collection. One hundred tablets were purchased from each product from the same batch/lot number. The samples were coded from A-F (A- generic/plastic container, B- generic/plastic container, C & F- branded/blister pack, D & E- branded/plastic container) to conceal the identity. The quality was tested following the British Pharmacopoeia 2020. Data were analyzed using IBM SPSS version 25.

**Results:** Paracetamol prices ranged from 2.20-4.16 LKR/tablet. Both blister packs and bulk plastic containers were available. Blister-packed pills were more expensive (4.16 LKR). All the tested paracetamol formulations complied with the BP specifications for quality except for the hardness test ( $> 100$  N). Samples passed the aesthetic, weight variation (average weight =  $500 \text{ mg} \pm 5 \text{ mg}$ ), friability ( $Q < 1\%$ ), disintegration (uncoated tablets  $< 15$  min, coated tablets  $< 30$  min), dissolution ( $C > 80\%$  in 45 min) and assay ( $C=95\%-105\%$ ) tests.

**Conclusion:** Bulk dispensing was cheaper than blister-packed paracetamol products. All generic products were available in plastic bulk containers, but branded formulations were in both packaging. The high hardness did not negatively affect the quality, as the disintegration and dissolution were within limits. Thus, it is concluded that all paracetamol formulations were up to the British Pharmacopoeia 2020 standards.

**Acknowledgment:** This research was funded by the research grant/2021 of the Faculty of Allied Health Sciences, University of Ruhuna.

PP 42

***In vitro* antioxidant activity of leaves and unripen fruits of “Tanin and Vega F1” hybrid papaya on the basis of DPPH free radical scavenging**

Needhiraja NP<sup>1</sup>, Krishnamoorthy T<sup>1</sup>, Jayasooriya ATR<sup>1</sup>, Srikokulan S<sup>1\*</sup>, Senthilnathanan M<sup>2</sup>

<sup>1</sup>Department of Pharmacy, Faculty of Allied Health Sciences, University of Jaffna, <sup>2</sup>Department of Chemistry, Faculty of Science, University of Jaffna, Sri Lanka.

**Background:** Unripen fruit and leaves of papaya are recognized as a remedy for preventing cancer and heart diseases by preventing the oxidation process. Due to the rising need for natural remedies for oxidation-related disease and the increased rate of consumption of hybrid varieties, the antioxidant activity of hybrid papaya was investigated *in-vitro*.

**Objective:** To find out the antioxidant activity of leaves and unripen fruits of “Tanin and Vega F1” hybrid papaya using IC<sub>50</sub> values.

**Methods & Materials:** The leaves and unripen fruits of “Tanin and Vega F1” hybrid papayas were collected from the Agricultural Research Centre in Jaffna, Sri Lanka. Methanolic and ethyl acetate extracts of leaves and unripen fruits were prepared using the maceration process. Subsequently, 2,2-diphenyl-1-picrylhydrazyl (DPPH) radical scavenging assay was performed separately on the extracts of the papaya samples to determine their antioxidant activities by employing ascorbic acid as the standard. The IC<sub>50</sub> values for the extracts were calculated from the respective DPPH assays. The statistical significance was evaluated by the analysis of variance (ANOVA) followed by Tukey’s test using SPSS software. Significance level was set at 0.05.

**Results:** The results revealed that the methanolic leaf extract of Vega F1 showed greater activity (652.507 µg/ml) and was significantly different (p<0.05) compared to that of the standard ascorbic acid (14.586 µg/ml). The radical scavenging activities of both Tanin and Vega F1 were in the order of Vega F1 leaf methanol extract > Tanin leaf methanol extract > Vega F1 unripe fruit methanol extract > Vega F1 unripe fruit ethyl acetate extract > Tanin unripe fruit methanol extract > Vega F1 leaf ethyl acetate extract > Tanin leaf ethyl acetate extract > Tanin unripe fruit ethyl acetate extract.

**Conclusion:** This study revealed that the methanolic extract of leaves of Vega F1 showed greater antioxidant activity compared to other extracts which could be a better source of antioxidants.

PP 43

**Invitro determination of alpha amylase inhibitory activity of two selected medicinal plants extracts**

Liyanaarachchi LVV<sup>1</sup>, Rathnayake HMAL<sup>1</sup>, Wijesundara WMAGUI<sup>1</sup>, Sivasinthujah S<sup>1\*</sup>, Manoranjan T<sup>2</sup>

<sup>1</sup>Department of Pharmacy, Faculty of Allied Health Sciences, University of Jaffna, Sri Lanka, <sup>2</sup>Department of Chemistry, Faculty of Science, University of Jaffna, Sri Lanka.

**Background:** Pancreatic  $\alpha$ -amylase inhibitors offer an effective strategy to reduce post-prandial hyperglycemia in the management of diabetes mellitus. In this study, two medicinal plants; *Trianthema decandra* and *Thespesia populnea* were subjected to determine the  $\alpha$ -amylase inhibitory activity. Though the alpha amylase activity of these above-mentioned plants has been investigated in different countries, the level of alpha amylase activity presence in these plants has not been investigated so far in Sri Lanka.

**Objective:** To determine the *in vitro* alpha amylase inhibitory activity of *T.decandra* and *T.populnea* leaves extracts using porcine pancreatic  $\alpha$ - amylase enzyme.

**Methods & Materials:** The leaves of *T.decandra* and *T.populnea* were collected from Jaffna, dried under shade, ground to a powder. The extractions were prepared by maceration with methanol, acetone and petroleum ether. Subsequently,  $\alpha$ -amylase inhibitory assay was performed separately on the leaf extracts of *T. decandra* and *T. populnea* by employing acarbose as the standard compound. The IC<sub>50</sub> values for the extracts were calculated from the respective assay. The statistical significance was evaluated by the analysis of variance (ANOVA) followed by Tukey’s test.

**Results:** The IC<sub>50</sub> values of leaf of methanol, acetone, petroleum ether extracts were 44.34±2.3  $\mu$ g/ml, 346.6±4.5  $\mu$ g/ml, 674.9±2.7 $\mu$ g/ml. Methanol, acetone and petroleum ether leaf extracts of *T. decandra* showed IC<sub>50</sub> values of 175.93±4.04  $\mu$ g/ml, 447.6±1.3  $\mu$ g/ml, and 1020.3±3.2  $\mu$ g/ml. The methanol extract of *T. populnea* showed significantly  $\alpha$ -amylase inhibition comparable to the acarbose (IC<sub>50</sub> = 83.85±2.64  $\mu$ g/ml) ( $p>0.05$ ). None of the petroleum ether extracts showed alpha amylase inhibitory activity.

**Conclusion:** The findings revealed that methanolic extract of *T.populnea* leaf extract exhibited  $\alpha$  – amylase inhibitory activity which could be used for further screening of specific bioactive compounds that might responsible for their  $\alpha$  amylase inhibitory activity.

## PP 44

### **Prescribing patterns of lipid lowering drugs at Teaching hospital, Karapitiya**

Edirisinghe EAAS<sup>1\*</sup>, Pathiraja VM<sup>1</sup>, Dhanarisi J<sup>2</sup>

<sup>1</sup>Department of pharmacy, Faculty of Allied Health Sciences, University of Ruhuna, Sri Lanka, <sup>2</sup>Local Production & Assistance Unit, Regulation and Prequalification Department, Access to Medicines and Health Products Division, World Health Organization, Geneva, Switzerland

**Background:** Cardiovascular Disease (CVD) is one of the major health burdens in Sri Lanka. The adult treatment panel IV (ATP IV) guideline endorsed statin use in clinical practice for the prevention of CVD through the proper management of blood cholesterol levels. It has introduced two prevention groups and three statin-intensity therapies that should be used with each prevention groups.

**Objective:** To assess whether the prescribing patterns of lipid-lowering drugs (LLDs) are in conformity with ATP IV guideline.

**Methods & Materials:** A hospital-based cross-sectional study was conducted from March to July 2022 among 400 patients (age>18 years) who were attending the medical clinic at Teaching Hospital, Karapitiya and prescribed with LLDs using a convenience sampling method. An interviewer-administered questionnaire was used as a data collection tool. The eligibility of the prescription was evaluated according to their risk factors, and then the dosing appropriateness of those eligible participants was assessed according to the guideline. The data were analyzed using the statistical package for the social science version 25.

**Results:** The majority of participants were female (54.3%) and in the 40–75 years (92%) age group. Almost all the participants, (96%, n=384) were found to be eligible to receive LLD therapy while 16 participants (4%) were not eligible according to ATP IV guideline. Out of 384 eligible participants, 56% (n=215) were prescribed appropriate statin therapy and 44% (n=169) were inappropriately prescribed. Atorvastatin was the first line therapy prescribed in 395 (98.8%) of the study subjects.

**Conclusion:** The majority of participants who were eligible to be prescribed LLD, received low doses of statins. It increases the risk of reoccurrence of atherosclerotic CVD. The study suggests that prescribing patterns should be strictly adhered to the ATP IV guidelines. The prescribers might be encouraged to improve prescribing patterns by implementing local guidelines based on ATP IV guideline.

## **PP 45**

### **Post-marketing quality assessment of metformin hydrochloride tablets available in Karapitiya**

Priyanath HYS\*, Jayasinghe M, Subasinghe HWAS, Wijesekara K

*Department of pharmacy, Faculty of Allied Health Sciences, University of Ruhuna, Sri Lanka.*

**Background:** Safe generic substitution depends on the quality of medicine formulations. Due to the price regulations by the National Medicines Regulatory Authority, metformin tablets are sold below a ceiling price.

**Objective:** This study aimed to evaluate the pharmaceutical quality of metformin tablets dispensed by the public and private sector community pharmacies.

**Methods & Materials:** Sampling was done from two community pharmacies, *Rajya-Osusala* outlet, and a public hospital pharmacy at Karapitiya suburb, Galle. Metformin tablets available in the sample collection site were taken for the study. From each product, 100 tablets were purchased from the same batch number/lot number in unopened packs. The study sample was composed of two brands (A & B) and four generics (C, D, E and F). Products were assessed for appearance, weight variation, assay, dissolution, disintegration, friability and hardness according to the British Pharmacopeia 2020. Data were analyzed using MS Excel and SPSS version 25. Significance level was set at  $p < 0.05$ .

**Results:** Two brands and three generics passed the weight variation test (average weight =  $500 \pm 5$  mg), friability  $> 1\%$ , assay 95-105%, dissolution  $> 80\%$  at 45 minutes, and disintegration  $< 30$  minutes. The hardness of all formulations was high ( $> 100$ N). The hospital sample failed the assay test (93.0%) and passed other tests. Though all formulations passed the dissolution test, different results were observed among the formulations. Therefore, mean values of dissolution assay results were further compared using multiple comparison in SPSS. Dissolution rates of A, B, and E varied in a closer range, and formulations C, D and F also showed close dissolution rates. There was a significant difference ( $p < 0.001$ ) in mean dissolution assay of these two groups.

**Conclusion:** All samples passed the quality tests except for the hospital sample (F) which failed the assay test. Frequent post-market quality assessment of both hospital and community pharmacy supplies should be a high priority to ensure the quality of medicines.

**Acknowledgment:** This research was funded by the research grant/2021 of the Faculty of Allied Health Sciences, University of Ruhuna.

**PP 46**

**Association of patient specific factors on the total weekly dose of warfarin**

Liyanage HS<sup>\*</sup>, De Silva KIM<sup>1</sup>, Prabodha LBL<sup>2</sup>

<sup>1</sup>Department of Pharmacy, Faculty of Allied Health Sciences, University of Ruhuna, Sri Lanka, <sup>2</sup>Department of Anatomy, Faculty of Medicine, University of Ruhuna, Sri Lanka.

**Background:** Warfarin is the most commonly used oral anticoagulant for the treatment and prevention of thromboembolic disorders. Managing warfarin therapy is challenging due to its narrow therapeutic index and the wide inter-individual variability in patient response.

**Objective:** This study aimed to evaluate patient-specific factors that associate with the total weekly dose (TWD) of warfarin in patients attending to cardiology clinic, Teaching Hospital Karapitiya.

**Methods & Materials:** A hospital-based descriptive cross-sectional study was conducted among patients having stable TWD of warfarin for three consecutive months. The study sample included 165 patients who were selected using a convenience sampling method. Data were collected, using an interviewer-administered questionnaire that included age, gender, ethnicity, weight, height, alcohol/ tobacco usage, concurrent medications, date of warfarin initiation, indication of warfarin, stabilized dose of warfarin, TWD, concomitant disease conditions and target INR range. Data were analyzed by using two sample t test, Pearson correlation test and ordinary least squares regression in SPSS version 26. Statistical significance was set at  $p < 0.05$ .

**Results:** The age of the study participant ranged from 20 to 92 years where mean (SD) age was 58.40 (13.26) years. The majority of the patients were Sinhalese (97%), with more females (57%). The warfarin dose ranged from 0.5 mg to 10 mg and mean (SD) TWD was 33.27 (13.06) mg. Age ( $p=0.007$ ), height ( $p=0.027$ ) and diuretic usage ( $p=0.003$ ) were the only statistically significant predictors of TWD in the regression analysis. The TWD was 2.1 mg less for each additional 10 years increase in patient age and TWD was 1.72 mg high for each additional 10 cm of patient height. As a concurrent medicine, diuretics showed to have affected the TWD of warfarin.

**Conclusion:** Age, height and concurrent use of diuretics were the factors associated with the TWD of warfarin. Positive relationships were found between TWD and height, and diuretic usage. Further studies need to be carried out with a large population to precisely predict the association of patient-specific factors on TWD to find out the additional relationships.

PP 47

**Nanoemulsions encapsulated with aqueous leaf extract of *Coccinia grandis* L. Voigt (Kovakka) as a potential nanonutraceutical agent against type 2 diabetes mellitus**

Wickramasinghe ASD<sup>1\*</sup>, Attanayake AP<sup>2</sup>, Kalansuriya P<sup>2</sup>

<sup>1</sup>Department of Pharmacy, Faculty of Health Sciences, The Open University of Sri Lanka, Department of Biochemistry, Faculty of Medicine, University of Ruhuna, Sri Lanka.

**Background:** Development of a standardized nutraceutical formulation using *Coccinia grandis* (L.) Voigt leaves with scientifically proven glucose-lowering ability has been hindered by its drawbacks in solubility, oral absorption and stability.

**Objective:** To encapsulate crude extracts derived from *C. grandis* leaves into nano emulsions and to determine their glucose-lowering ability using a high-fat diet fed-streptozotocin induced Wistar rat model.

**Methods & Materials:** *C. grandis* derived aqueous crude extract was prepared by ultrasonication (40 °C, 40 kHz, 30 min) and was encapsulated into nano emulsions composed of olive oil, kolliphor HS15 and phosphatidylcholine. Resulting nano emulsion was characterized using particle size, zeta potential and fourier-transform infrared spectroscopy (FTIR) analysis. The glucose-lowering ability of the optimized nano emulsion was screened by an oral glucose tolerance test (OGTT, 3 g/kg) using diabetic rats and expressed in terms of the total area under the OGTT curve (TAUC). Ethical clearance for this study was granted by Ethics Review Committee, University of Ruhuna [2020.P.004 (21.01.2020)].

**Results:** Optimum encapsulation of *C. grandis* aqueous extract into nano emulsion was achieved at a loading concentration of 45 mg/mL with an encapsulation efficiency and loading capacity of 91.8±0.5% and 0.6±0.0%, respectively. The particle size, polydispersity index and zeta potential of *C. grandis* encapsulated nano emulsions were 166.8±0.3 nm, 0.333±0.004, and -24.3±1.1 mV. Physical entrapment of compounds inside the oil core of nano emulsion was evident in FTIR data. The percentage reduction of TAUC exerted by nano emulsion treated rats was 15.3% (p=0.003) and 12.0% (p=0.019) compared to diabetic control rats and crude extract treated rats, respectively, and was comparable to the metformin (300 mg/kg) treated rats (positive control group). Void nano emulsion did not exert any glucose-lowering activity.

**Conclusion:** The glucose-lowering ability of the crude extracts derived from *C. grandis* leaves can be enhanced by encapsulating into a nano emulsion, which could be developed as a potential nano nutraceutical agent against type 2 diabetes mellitus.

**Acknowledgement:** This study was funded by World Bank under the AHEAD/DOR/15 grant.

**PP 48**

**Knowledge on the adverse drug reaction monitoring and reporting system among nursing officers: A descriptive cross-sectional study**

Sitheja WGV<sup>1\*</sup>, Jayasinghe M<sup>2</sup>, Dissanayake AS<sup>2</sup>

<sup>1</sup>Department of Nursing, Faculty of Allied Health Sciences, University of Ruhuna, Sri Lanka, <sup>2</sup>Department of Pharmacy, Faculty of Allied Health Sciences, University of Ruhuna, Sri Lanka.

**Background:** The role of nursing officers in adverse drug reaction (ADR) monitoring and reporting is extensive. However, the nurses' contribution could be further improved in Sri Lanka.

**Objective:** This study aimed to assess the knowledge of nursing officers on the adverse drug reaction monitoring and reporting system in Sri Lanka.

**Methods & Materials:** A cross-sectional study was conducted in a multidisciplinary tertiary care hospital in Karapitiya. A self-prepared, pre-tested, self-administered questionnaire was distributed among a sample of 423 nursing officers. Nurses were selected from all wards and units in the hospital using a cluster sampling method. Data were analyzed using descriptive statistics and the SPSS version 25. The overall knowledge scores were calculated based on the number of correct answers and divided into three categories of knowledge [i.e., low (0-6), moderate (7-9), and high (10-12)].

**Results:** The majority (n=276, 65.3%) of nursing officers were below 40 years of age. Of the participants, 46.8% had work experience of more than ten years. Most (n=348, 82.3%) of the participants had followed a diploma in nursing. None of the nurses had received training on adverse drug reaction monitoring and reporting during their education/training or work placements. Only (7.8%, n=33) of nurses had a high level of knowledge. The majority (74.5%, n=315) of nurses had a low level of knowledge. The mean (SD) knowledge score was 4.27 ( $\pm 1.73$ ). All participants knew what an ADR is; only 2.1% (n=2) of nurses knew the responsible authority to report an ADR. All the nurses stated that only the patient's information was sufficient to initiate an ADR report.

**Conclusion:** Most nursing officers knew little about adverse drug reaction monitoring and reporting. All nurses should have a high level of knowledge to improve the spontaneous reporting of ADR. Hence, a continuous professional development program is recommended to provide the training and development necessary.

## PP 49

### **Invitro antimicrobial efficacy of an herbal eye wash against pathogens causing conjunctivitis**

Ambujan B<sup>1</sup>, Damayanthi HLI<sup>1\*</sup>, Uluwaduge DI<sup>2</sup>, Peiris KPP<sup>3</sup>, Bandara EMS<sup>1</sup>

<sup>1</sup>Department of Medical Laboratory Sciences, Faculty of Allied Health Sciences, University of Sri Jayewardenepura, Sri Lanka, <sup>2</sup>Department of Basic Sciences, Faculty of Allied Health Sciences, University of Sri Jayewardenepura, Sri Lanka, <sup>2</sup>Department of Biochemistry and Clinical Chemistry, Faculty of Medicine, University of Moratuwa, Sri Lanka, <sup>3</sup>Department of Shalya Shalakya, Faculty of Indigenous Medicine, Gampaha Wickramarachchi University of Indigenous Medicine, Sri Lanka.

**Background:** Conjunctivitis is an eye disease characterized by inflammation of the conjunctiva, which is caused by numerous pathogens like *Staphylococcus aureus*, *Streptococcus pneumoniae*, *Escherichia coli*, *Pseudomonas aeruginosa*, and *Candida albicans*. Herbal plants contain phytochemical constituents, and some phytochemicals have antimicrobial activities. Further, some medicinal plants have been proven effective in treating conjunctivitis.

**Objective:** We aimed to assess the anti-microbial efficacy of herbal eyewash preparation against the selected pathogens that may cause conjunctivitis. Some are isolated from reference strains and others are clinically isolated to determine the Minimum Inhibitory Concentration (MIC) and the shelf life of the prepared eyewash.

**Methods & Materials:** This study is an *in-vitro* laboratory-based experimental study. Poly-herbal extraction was prepared in a clay pot with 4:1 ratio, using 50 g of each raw materials, fruit carp of *Terminalia chebula*, fruit carp of *Terminalia bellirica*, fruit of *Phyllanthus emblica*, stem of *Tinospora cordifolia*, and stem of *Coscinium fenestratum*. The antimicrobial activity of the crude extract was determined against selected pathogens causing conjunctivitis. Freeze-dried powder of the herbal extract was used to determine the MIC of the pathogens by using the pour plate method. Dilution series was prepared using freeze dried powder. These were added to the plate using pour plate method. We investigated the visible growth of each microorganism. Shelf life of the poly herbal extract was determined to check stability by comparing with one-month old extract and fresh extract.

**Results:** The plant extract showed effective antibacterial activity against *Staphylococcus aureus* (26.33±1.52mm), *Streptococcus pneumoniae* (14.66±0.57mm), *Escherichia coli* (13.33±0.57mm), and *Pseudomonas aeruginosa* (21.67±1.52mm). However, the extract did not show antifungal effect against *Candida albicans* though it was repeated. The MIC of *Escherichia coli* and *Pseudomonas aeruginosa* were 62.5 mg/ml. The MIC for *Streptococcus pneumoniae* were 31.25 mg/ml. The MIC for *Staphylococcus aureus* was 15.63 mg/ml. Reduction percentage of antimicrobial activity of polyherbal eyewash for *Staphylococcus aureus*, *Streptococcus pneumoniae*, *Escherichia coli*, *Pseudomonas aeruginosa* were 26.5%, 20.9%, 15.0%, 18.4% respectively.

**Conclusion:** The authentic polyherbal preparation was effective against *Staphylococcus aureus*, *Streptococcus pneumoniae*, *Escherichia coli*, and *Pseudomonas aeruginosa* that may cause conjunctivitis. Therefore, it can be suggested to be suitable for further testing as an eye wash in Ayurvedic medicine. As its shelf life was low by comparing reduction percentage of extract, it would be good to use freshly prepared extract to obtain maximum efficiency.

PP 50

## Price, availability and supplier comparison of price-controlled medicines in Sri Lanka

Shashiprabha NAB<sup>1\*</sup>, Jayasinghe M<sup>1</sup>, Dorabawila SSKBM<sup>2</sup>

<sup>1</sup>Department of Pharmacy, Faculty of Allied Health Sciences, University of Ruhuna, Sri Lanka, <sup>2</sup>Department of Economics and Statistics, Faculty of Arts, University of Peradeniya, Sri Lanka.

**Background:** Access to medicines is determined by price and availability. The National Medicine Regulatory Authority (NMRA) implements a price ceiling policy on a selected list of drugs.

**Objective:** This study aimed to examine the availability, prices, and suppliers of price-controlled medicines in retail pharmacies in Sri Lanka.

**Methods & Materials:** A descriptive, cross-sectional study was conducted in August 2022 following the WHO/HAI methodology. Considering the population density, six survey areas were selected (Colombo, Gampaha, Kalutara, Kandy, Galle, and Matara). Five private retail pharmacies and one *Rajya Osu Sala* (SPC) outlet were selected from each area. Seventeen drugs were sampled from the price-controlled drug list published on 29.04.2022. A pre-prepared table was used to record the data. The price and availability were recorded if the drug was available in the pharmacy on the day of the visit. The country of suppliers was taken from the NMRA public database and compared with the labels of medicines during the visit.

**Results:** The availability of price-controlled drugs ranged from 42% - 100%. Thirteen drugs showed high availability (> 80%), two drugs showed fairly high availability (50% – 80%), and two drugs showed low availability (30% – 49%). More than twenty different formulations were available for omeprazole 20 mg capsule, atorvastatin 20 mg tablet, gliclazide 80 mg tablet, and metformin 500 mg tablet. For other drugs (n=13), less than ten different formulations were available. Atorvastatin 20 mg tablets showed the highest (1:18) inter-brand price variation and beclomethasone 250 microgram inhalation showed the lowest (1:1.08). The major suppliers (94.65%) of price-controlled medicines were from middle-income countries (India-73.26%, Sri Lanka-6.95%, Bangladesh-6.42%), and 5.35% of the supply was from high-income countries.

**Conclusion:** Approximately 2/3 of price-controlled drugs had high availability in retail pharmacies. High inter-brand price variations were observed with some products. The primary supplier of price-controlled medicines was India.

## PP 51

### Antibiotic resistance patterns of *Escherichia coli* in paediatric urinary tract infections

Wickramarathne DKN<sup>1,2</sup>, Herath HMCK<sup>1,3</sup>, Chathurika PTC<sup>4</sup>, Nissanka NMC<sup>4</sup>, Dassanayake M<sup>2</sup>, Wimalagunawardana P<sup>3</sup>, Dilhari KAA<sup>4\*</sup>

<sup>1</sup>Department of Medical Laboratory Sciences, The Open University of Sri Lanka, Sri Lanka, <sup>2</sup>Lady Ridgeway Hospital, Sri Lanka, <sup>3</sup>District General Hospital, Polonnaruwa, Sri Lanka, <sup>4</sup>Department of Basic Sciences, Faculty of Allied Health Sciences, University of Sri Jayewardenepura, Sri Lanka.

**Background:** Most paediatric urinary tract infections (UTIs) are caused by *E. coli*. Its resistance to antibiotics compromises the effectiveness of empiric therapy. Further, there is a paucity of evidence on *E. coli*'s antibiotic resistance in paediatric UTI, Sri Lanka.

**Objective:** To determine the antibiotic resistance of *E. coli* in paediatric UTIs.

**Methods & Materials:** A descriptive, cross sectional prospective study was conducted for a period of eight months at District General Hospital, Polonnaruwa, and Lady Ridgeway Hospital, Colombo with culture-positive urine specimens (n=506). *E. coli* was identified through direct microscopy and culture on Cystine Lactose Electrolyte Deficient (CLED) media followed by colony count and battery of other biochemical testing. Antibiotic Susceptibility Testing was then performed according to Clinical and Laboratory Standards Institute (CLSI) standards.

**Results:** Out of 506 children with UTI, *E. coli* was isolated from 274. Of them, there were 4 neonates (<1 month), 43 infants (1 month-1 year), 93 toddlers and preschoolers (1-5 years), 134 school-aged children (5-14 years). Among neonates, 25% (1/4) of *E. coli* were resistant to co-amoxiclav, cefotaxime, cephalexin, nalidixic acid and ciprofloxacin. Among infants, cephalexin (32/43; 74.4%) showed the highest resistance followed by co-amoxiclav (19/43; 44.2%), cefotaxime and nalidixic acid (17/43; 39.5%), co-trimoxazole (16/43; 37.2%) and ciprofloxacin (12/43; 27.9%). However, gentamicin, netilmicin, nitrofurantoin, amikacin, meropenem and imipenem showed 19-4% resistance. Children more than 1-year-old showed highest resistance rates against cephalexin (146/227; 64.3%) followed by nalidixic acid (117/227; 51.5%), co-amoxiclav (92/227; 40.5%), cefotaxime (89/227; 39.2%), co-trimoxazole (83/227; 36.6%) ciprofloxacin (61/227; 26.9%), and gentamicin (34/227; 15.0%). In contrast, nitrofurantoin, amikacin, meropenem, imipenem, and netilmicin showed least resistance rates (13.0-1.0%). Seventy-six ESBL (Extended-Spectrum Beta-Lactamase) producing *E. coli* were isolated from 1 neonate, 13 infants, 28 toddlers and preschoolers, 34 school-aged children, providing resistance to broad-spectrum cephalosporins. ESBL producers were least resistant to imipenem and meropenem (3/76; 3.9%).

**Conclusion:** Cephalexin, co-amoxiclav, cefotaxime, nalidixic acid, co-trimoxazole and ciprofloxacin had the highest resistance rates against *E. coli*. When treating paediatric UTI, carbapenems are still effective particularly against ESBL producers. The current data would serve as a basis until extensive analysis comprising numerous centers is done.

## PP 54

### ***In vitro* carbohydrate metabolizing enzyme inhibitory potential of alginate nanoparticles encapsulated of *Catharanthus roseus* L. extracts**

De Silva WND<sup>1\*</sup>, Attanayake AP<sup>1</sup>, Arawwawala LDAM<sup>2</sup>, Karunaratne DN<sup>3</sup>, Pamunuwa KMGK<sup>4</sup>

<sup>1</sup>Department of Biochemistry, Faculty of Medicine, University of Ruhuna, Sri Lanka, <sup>2</sup>Industrial Technology Institute, Sri Lanka, <sup>3</sup>Department of Chemistry, Faculty of Science, University of Peradeniya, Sri Lanka, <sup>4</sup>Department of Horticulture and Landscape Gardening, Faculty of Agriculture and Plantation Management, Wayamba University of Sri Lanka, Sri Lanka.

**Background:** *Catharanthus roseus* L. (Family: Apocyanaceae) is a widely known plant for its antidiabetic potential. Efforts to improve the antidiabetic activity of herbal extracts have recently turned in the way of developing nanoparticle encapsulated herbal extracts and assessing their efficacy using different carbohydrate metabolizing enzymes.

**Objective:** To assess and compare  $\alpha$ -amylase,  $\alpha$ -glucosidase, and dipeptidyl peptidase IV (DPP-IV) inhibitory potential of alginate nanoparticles (ANs) encapsulated ethanol, 50% ethanol and 50% acetone extracts of *C. roseus*.

**Methods & Materials:** ANs were encapsulated with leaf ethanol (2 mg/ml), 50% ethanol (3 mg/ml) and 50% acetone (3 mg/ml) extracts of *C. roseus* by ionic gelation method. Successful formation of ANs encapsulated *C. roseus* extracts was confirmed by scanning electron microscopy (SEM), and Fourier Transform Infrared (FTIR) spectroscopy analysis. The particles were further characterized by determining particle size, zeta potential, encapsulation efficiency (EE%) and loading capacity (LC%). The formulated ANs were evaluated for their  $\alpha$ -amylase,  $\alpha$ -glucosidase, and DPP-IV inhibitory potentials *in vitro*.

**Results:** ANs encapsulated ethanol extract of *C. roseus* showed the highest LC% of 3.25%, while its EE%, particle size, zeta potential were 81.29%, 211.4 nm, -35.0 mV respectively. FTIR spectroscopy and SEM indicated the successful encapsulation of *C. roseus* extracts into alginate matrix. Of the three nanoparticles, ANs encapsulated ethanol extract of *C. roseus* showed the highest significant activity with an improved percentage of inhibition for  $\alpha$ -amylase (32.43%), and  $\alpha$ -glucosidase (78.68%). The highest significant inhibition for DPP-IV enzyme (48.89%) was shown by ANs encapsulated acetone extract of *C. roseus* compared to the crude acetone extract ( $p < 0.05$ ).

**Conclusion:** ANs encapsulated ethanol extract of *C. roseus* had potent carbohydrate metabolizing enzyme inhibitory potential among the three nano formulations whereas the ANs encapsulated acetone extract of *C. roseus* showed the highest inhibition in DPP-IV enzyme assay. The results revealed that the ANs encapsulated ethanol and acetone extracts of *C. roseus* could be potent sources for the development of nano encapsulated herbal therapeutics to be used in the management of diabetes mellitus.

**Acknowledgement:** Financial assistance AHEAD DOR-15.

## PP 55

### **Invitro antioxidant potential of *Hemidesmus indicus* (Iramusu)**

Madhuranga HDT<sup>\*</sup>, Gunasena GKBCM<sup>1</sup>, Dharmasena WASH<sup>1</sup>, Thambiliyagoda TGKU<sup>1</sup>, Riham MCM<sup>1</sup>, Samarakoon DNAW<sup>1</sup>, Herath HMLPB<sup>2</sup>

<sup>1</sup>Department of Biomedical Science, Faculty of Health Science, KAATSU International University (KIU), Sri Lanka,

<sup>2</sup>Department of Chemistry, Faculty of Science, University of Colombo, Sri Lanka.

**Background:** The majority of deaths worldwide have been caused by non-communicable diseases; these conditions are linked with Reactive Oxygen Species (ROS). Antioxidants can reduce oxidative stress which will reduce the majority of the unwanted effects of non-communicable diseases. Natural herbal medicines, which have little or no adverse effects, are the focus of modern science. *Hemidesmus indicus* R. Br. (Periplocaceae) found in Sri Lanka is used in a variety of ayurvedic preparations. However, the antioxidant activity of aqueous plant extract remains unknown.

**Objective:** The purpose of this study was to investigate the antioxidant properties of *H. indicus* aqueous plant extract using DPPH (2,2- Diphenyl-1-Picrylhydrazyl), H<sub>2</sub>O<sub>2</sub> (Hydrogen peroxide), and Ferric Reducing Antioxidant Power (FRAP) assays.

**Methods & Materials:** Plants were collected and using the maceration method, plant components (whole plant without roots) were extracted into distilled water in a 1:3 ratio and stored in a deep freezer until aqueous extract powder was obtained. A series of two-fold dilutions were created: 1 g of plant aqueous extract powder dissolved in 1 ml of distilled water, starting from 1g ml<sup>-1</sup> to 2 ×10<sup>-3</sup> g ml<sup>-1</sup> concentration. As per the standard, ascorbic acid was used for all three assays. Then, the absorbance was measured by a UV double-beam spectrophotometer, and the IC<sub>50</sub> values were calculated using *GraphPad Prism* software. The study was triplicated.

**Results:** When considering the DPPH assay, IC<sub>50</sub>2.6 gml<sup>-1</sup> for the plant was observed, which was comparatively higher than the standard IC<sub>50</sub>=0.15 g ml<sup>-1</sup>. In the H<sub>2</sub>O<sub>2</sub> assay, the plant showed IC<sub>50</sub>=0.0015 gml<sup>-1</sup>, which was compared with the standard IC<sub>50</sub>=0.0017 gml<sup>-1</sup>. In the FRAP assay, IC<sub>50</sub>=3.31 gml<sup>-1</sup> for the plant was observed, which was comparatively higher than the standard IC<sub>50</sub>=2.38 gml<sup>-1</sup>.

**Conclusions:** This shows that *H. indicus* has an antioxidant capacity, but in these assays, the IC<sub>50</sub> values are higher than the standard IC<sub>50</sub>. *H. indicus* is popular among ayurvedic traditional medical practitioners for the treatment of diabetes mellitus, and cancer, which are directly associated with ROS.

## PP 56

### **Evaluation of online pharmacies operating in Sri Lanka**

Hansanie SMN\*, Mannapperuma U

*Department of Pharmacology, Faculty of Medicine, University of Colombo, Sri Lanka.*

**Background:** Online pharmacies provide greater convenience by allowing online purchase of medicines. World Health Organization (WHO) provides a legal and regulatory framework for online pharmacy operations. The National Medicines Regulatory Authority (NMRA) of Sri Lanka is yet to provide guidelines for the operation of online pharmacies.

**Objective:** This study aimed to evaluate characteristics of online pharmacies operating in Sri Lanka to determine if they meet the recommendations made by the WHO.

**Methods & Materials:** The websites of 22 online pharmacies operating in Sri Lanka were accessed in December, 2022. They were assessed using a checklist containing 16 website characteristics according to the recommendations by the WHO for community pharmacies in the European Region. Descriptive statistics were used to describe the characteristics. Associations between selected characteristics were assessed by the Fisher’s exact test. Significance level was set at  $p < 0.05$ .

**Results:** A prescription was required for ordering medicines in 16 (72.7%) pharmacies. Over-the-counter (OTC), and prescription-only medicines (POMs) were classified in 15 (68.2%). Availability and prices were displayed in 7 (31.8%). Hours of opening, terms and conditions for ordering and statement of ensuring confidentiality of the details provided were displayed in 14 (63.6%), 13 (59.1%), and 9 (40.9%) respectively. None provided information about the responsible pharmacist. Contact number and physical address were mentioned on all. Only 10/22 (45.5%) contained more than 8 (50%) characteristics of the checklist. Pharmacies with a clear differentiation of OTC and POM medicines displayed availability and prices of the medicines ( $p < 0.05$ ), terms and conditions for ordering ( $p < 0.01$ ) and a statement of ensuring confidentiality ( $p < 0.01$ ).

**Conclusion:** The results of this study indicate that many online pharmacies in Sri Lanka are not operating according to the WHO recommendations. Pharmacies differentiating OTC and POM medicines were more likely to operate according to the WHO recommendations. Online pharmacies operating in Sri Lanka require strict regulatory supervision.

PP 57

**Determination of *invitro* antioxidant potential of *Hylocereus polyrhizus* seeds**

Kalidha Farween MR\*, Jayani DKD, Madhuranga HDT, Samarakoon DNAW

Department of Biomedical Sciences, Faculty of Health Sciences, KAATSU International University (KIU), Sri Lanka.

**Background:** Free radicals lead to the formation of many degenerative diseases, including cancer, diabetes, and aging. Natural herbal medicines are the focus of modern science due to their fewer adverse effects. *Hylocereus polyrhizus* (Cactaceae) is a natural fruit known as “dragon fruit or pitahaya”, found in Sri Lanka and used in a variety of food preparations. Although previous literature findings revealed the dragon fruit seed’s antioxidant potential using ethanol, methanol, or chloroform extracts, there is a lack of scientific evidence regarding dragon fruit seed’s aqueous antioxidant capacity findings particularly.

**Objective:** The purpose of this study was to investigate the antioxidant properties of *H. polyrhizus* seeds using H<sub>2</sub>O<sub>2</sub>, and Ferric Reducing Antioxidant Power (FRAP) assays.

**Methods & Materials:** Plants were collected from Kuliyaipitiya, Kurunegala District, and components were extracted using maceration. The extract was dried, and the powder was collected. Series of two-fold dilutions were created. Ascorbic acid was used as the standard. Seed’s aqueous powder concentration IC<sub>50</sub> values were compared with standard IC<sub>50</sub>. The log concentration-time graph was plotted and the IC<sub>50</sub> was detected using a non-linear regression model using *GraphPad Prism* software. According to the literature, If IC<sub>50</sub> < standard IC<sub>50</sub>, it is considered as having better antioxidant activities, and if IC<sub>50</sub> > standard IC<sub>50</sub>, it is considered as less/not having antioxidant activities.

**Results:** When considering the H<sub>2</sub>O<sub>2</sub> assay, the plant seed extract showed IC<sub>50</sub>=0.772 gml<sup>-1</sup>, which was compared with the standard IC<sub>50</sub>=2.531 gml<sup>-1</sup>. In the FRAP assay, IC<sub>50</sub>= 0.283 gml<sup>-1</sup> for the plant was observed, which was comparatively lower than the standard IC<sub>50</sub>=3.95 g ml<sup>-1</sup>.

**Conclusion:** Results showed that *H. polyrhizus* seeds have good antioxidant properties. Further research may allow for the isolation of active compounds, which might lead to natural drug therapy.

**PP 58**

**Level of medication adherence among adult patients with chronic kidney disease attending Teaching Hospital Karapitiya**

Nadeesha NVP, Prabhashini HLP, Priyadarshani SVGN, Kandambi THS, Madhumali DH, Hasanthika WWR, Nisansala MWN, Senarath NSASN

*Department of Nursing, Faculty of Nursing, KAATSU International University (KIU), Sri Lanka.*

**Background:** Chronic Kidney Disease (CKD) is a global health concern, and the incidence is gradually increasing due to multifactorial causes. Medication adherence is vital to reduce the progression of CKD and improve the quality of life. However, the study field is less explored in the local setting.

**Objective:** The current study aimed to assess the level of medication adherence among adult patients with CKD attending Teaching Hospital Karapitiya (THK), Sri Lanka.

**Methods & Materials:** A descriptive-cross-sectional study was carried out among 330 patients attending THK from May to August 2022. Data was collected by simple random sampling method. The Morisky Medication Adherence Scale (MMAS-8) was used to determine the level of adherence. Total MMAS scores were categorized as high (score 8). Medium (score 6-8), and low (< 6). SPSS version 25 was used as a statistical tool. Ethical approval was obtained by the Ethical Review Committee, KAATSU International University, Sri Lanka. Significance level was set at  $p < 0.05$ .

**Results:** Age range and mean age of patients were 18-81 years old and  $50.9 \pm 13.58$  years old respectively. The majority were male (64.5%), Sinhalese (79.1%), educated above grade 5 (63%), married (83%), and employed (70%). Only 6.8% exceeded the level of income of more than 45,000 LKR. High, medium, and low levels of adherence were 37.6%, 54.1%, and 8.25% respectively. The level of medication adherence was associated with ethnicity ( $p=0.017$ ), religion ( $p=0.033$ ), education level ( $p=0.002$ ), employment status ( $p=0.015$ ), monthly income ( $p=0.001$ ), and was not associated with the gender ( $p=0.165$ ), and marital status ( $p=0.062$ ).

**Conclusion:** Most patients had high and medium levels of adherence. The level of medication adherence was associated with ethnicity, religion, employment status, monthly income, and level of education.

## **PP 59**

### **Development, translation, and validation of a pharmacy literacy tool for English or Sinhala speaking population**

Wijesinghe DS\*, Senadheera GPSG, Samaranyake NR

*Department of Pharmacy and Pharmaceutical Sciences, Faculty of Allied Health Sciences, University of Sri Jayewardenepura, Sri Lanka.*

**Background:** Already available pharmacy literacy tools are not comprehensive and the majority of them are developed for Western populations or specific disease categories. Comparable tools in Sinhala language are scarce in literature.

**Objective:** To develop, validate (face and content), and translate (to Sinhala) a pharmacy literacy tool for the measurement of pharmacy literacy among English or Sinhala speaking Sri Lankan patients.

**Methods & Materials:** Pharmacy literacy tool was first developed in English. The items were initially selected through a literature survey taking into consideration the limitation and strengths of already available tools and brainstorming among researchers. English version was content validated by disseminating the tool among 15 experts in the health-related fields. The face validation of the tool was done by administering the content validated tool among 10 patients of the study population. The new versions were obtained by adjusting/adding/deleting items according to expert comments and discussion among researchers at the end of each step. The tool was then translated to Sinhala language according to WHO 2013 recommended protocol and “Principles of Good Practice for Translation and Cultural Adaptation Process for Patient-Reported Outcomes”. The Sinhala version of the tool was again validated (content and face) in the same way as the English version.

**Results:** A pharmacy literacy tool consisting of 39 multiple choice questions was developed, validated (content and face), and translated to Sinhala. The translated version was again validated (content and face). Scale level content validity index (S-CVI/Ave) was 0.93 and 0.96 for the English and Sinhala versions respectively, proving excellent content validity. The tools covered pharmacy literacy on dosage forms, route of administration, instructions, storage, expiry/disposal, prescription misuse, and language fluency of information provided.

**Conclusion:** Both English and Sinhala versions of the pharmacy literacy tool was developed and validated (face and content) to assess pharmacy literacy. Assessment of psychometric properties of 600 Sri Lankan patients attending three selected government hospitals is ongoing.

**Acknowledgement:** University Research Grants (ASP/01/RE/AHS/2022/89), University of Sri Jayewardenepura, Sri Lanka.

## PP 60

### **Development of indicators for medication safety during administration of medicines by healthcare professionals and patients in Sri Lanka**

Weliwatte IP<sup>1\*</sup>, Samaranyake NR<sup>2</sup>, Jayawardane P<sup>1</sup>, Galappathy P<sup>3</sup>

<sup>1</sup>Department of Pharmacology, Faculty of Medical Sciences, University of Sri Jayewardenepura, Sri Lanka, <sup>2</sup>Department of Pharmacy and Pharmaceutical Sciences, Faculty of Allied Health Sciences, University of Sri Jayewardenepura, Sri Lanka,

<sup>3</sup>Department of Pharmacology, Faculty of Medicine, University of Colombo, Sri Lanka.

**Background:** Safe and accurate administration of medicines is a critical step in providing proper medical care. The objective of the study was to develop indicators for safe administration of medicines by healthcare professionals or by patients themselves using an evidence based accepted methodology.

**Methods & Materials:** The RAND/UCLA (Research AND Development/University of California Los Angeles) appropriateness method was used with a panel of fifteen experts including senior pharmacologists, academic staff, physicians, pharmacists and nurses. From a systematic review and brainstorming sessions, 19 indicators were developed with defined numerators and denominators. During two rating rounds, each indicator was rated on six parameters; appropriateness, relevance, measurability and feasibility, clarity, usefulness, and comparability, using a 1-9 likert scale, where 9 considered as highly appropriate. If all the parameters were rated with a panel median of  $\geq 7$  without disagreement, those indicators were accepted. Overall consensus of the panel was obtained at a meeting with all experts.

**Results:** The panel rated 18 indicators as necessary for assessing safe administration of medicines, identifying fourteen core and four supplementary indicators. Among all the selected indicators, there were fourteen process indicators, two structural indicators, and two outcome indicators. Of them, thirteen indicators were applicable for inpatient patients. They included ensuring five rights of medication administration (the right patient, drug, dose, route and time), proper documentation, labeling of high-alert medicines and reconstituted IV solutions, correct use of technological devices, single-use vials and devices, and providing proper medication advice to patients. Four indicators, which were applicable for patients residing at home, were on labeling and storage of medicines.

**Conclusion:** The study identified 18 indicators which could be used to assess the safety in administration of medicines and to determine the impact of interventions to improve safety outcomes of medicines with the implementation of the National Action Plan for Medication Safety in Sri Lanka.

**Acknowledgement** University Research Grants, USJ: Grant No. ASP/RE/MED/2019/51.

## **PP 61**

### **Evaluation of cosmetic skin cream labels available in Sri Lanka**

Jayasekara ST, Senadheera GPSG, Samaranayake NR, Nadeshkumar A\*

*Department of Pharmacy and Pharmaceutical Sciences, Faculty of Allied Health Sciences, University of Sri Jayewardenepura, Sri Lanka.*

**Background:** Cream is a semisolid emulsion which is used widely in the cosmetic industry. Lack of important information on label may lead to undesired effects to users. There is an urgent need to evaluate the information available on labels of cosmetic creams currently available in Sri Lanka.

**Objective:** To develop standards on labeling of cosmetic skin creams and to evaluate the labels of cosmetic skin creams available in Sri Lanka based on the standards developed.

**Methods & Materials:** Modified Delphi method was used. Based on a detailed literature search, an initial list of standards was developed. A multidisciplinary panel of 10 experts rated each standard for the necessity criteria in a five-point Likert scale. Standards with an overall panel median score of  $\geq 4$  with agreement were selected. A cross sectional descriptive multicentric study was done to collect the data from all the cosmetic cream labels available from pharmacies and supermarkets during April 2022. They were assessed against the standards developed.

**Results:** Nineteen standards were finalized. Data from a total of 148 cosmetic skin cream labels were collected. All the labels contained brand name, function and net content. Around 93.9% labels (n=139) contained product category. Only 79.1% labels (n=117) were with manufacturing date and 77.7% labels (n=115) with expiry date. Around 72.3% labels (n=107) contained batch number or lot number. Only 49.3% labels (n=73) contained country of manufacture.

**Conclusion:** A set of standards to evaluate the cosmetic skin cream labels were developed using standard methodology. Most standards were adhered to by more than 50% of the cosmetic labels and this could be improved further if the manufacturers/importers adhere to the standards developed.

## PP 62

### **Labeling practice and associated factors of community pharmacies at municipality areas in Jaffna and Kandy Districts**

Peiris DAAY<sup>1</sup>, Madhushika WT<sup>1</sup>, Udabage UGDE<sup>1</sup>, Thuvaragan S<sup>1\*</sup>, Sanchayan K<sup>2</sup>

<sup>1</sup>Department of Pharmacy, Faculty of Allied Health Sciences, University of Jaffna, Sri Lanka, <sup>2</sup>Department of Pharmacology, Faculty of Medicine, University of Jaffna, Sri Lanka.

**Background:** Dispensing labels on medicines provide administration and other important instructions. Proper written communication on dispensing labels could reduce medication errors.

**Objective:** This study assessed community pharmacies' labeling practice and associated factors at municipality areas in Jaffna and Kandy Districts in Sri Lanka.

**Methods & Materials:** A descriptive cross-sectional study was conducted among 121 community pharmacies in municipality areas in Jaffna and Kandy Districts in Sri Lanka using a checklist and an interviewer-administered questionnaire. The checklist was used to collect information on labeling practice, and the interviewer-administered questionnaire was used to collect information on socio-demographic factors, work-related factors and pharmacy related factors. Investigator visited community pharmacies with valid prescriptions and collected dispensing labels from pharmacy personnel. Five prescriptions for azithromycin tablets, celecoxib capsules, pantoprazole delayed released tablets, hydrocortisone ointment and ciprofloxacin eye drops were used. The total score given for labeling practice was 50. Data were analyzed by using Statistical Package of Social Science (SPSS) version 26. The association of factors on labeling practice in community pharmacies was determined by an independent sample t-test and one-way ANOVA test. Significance level was set at  $p < 0.05$ .

**Results:** A total of 490 dispensing labels were collected from 98 community pharmacies. The patient's name, medicine name, dosage, frequency, the quantity of drugs, duration of treatment, specific instructions, pharmacy name/address and pharmacist name/signature were written on 8.16%, 94.08%, 73.67%, 98.57% 25.92%, 30.20%, 69.39%, 44.29% and 4.08 % of labels respectively. Number of dispensers working in the pharmacy ( $p=0.046$ ), age of the participants ( $p=0.040$ ), and duty satisfaction ( $p=0.032$ ) were significantly associated with labeling practice.

**Conclusion:** The labeling practice on dispensed medicines was not satisfactory in the municipality areas of the Jaffna and Kandy Districts. Number of dispensers working in the pharmacy, the age of the participants, and duty satisfaction were found to be significant associated factors on labeling practice.

## **PP 63**

### **Formulation of nutrient supplement from selected local grain varieties and comparison of their nutritional properties**

Perera TPSS, Navaratna SB, Prashantha MAB, Godakumbura PI\*

*Department of Chemistry, Faculty of Applied Sciences, University of Sri Jayewardenepura, Sri Lanka.*

**Background:** Edible grains are rich in nutrients, minerals and phytochemicals. Rice is the staple in South Asian countries and meets a substantial portion of people’s energy and nutritional needs.

**Objective:** This research is focused to formulate and develop a composite flour, rich in protein and other essential nutrients using selected local grain varieties in Sri Lanka.

**Methods & Materials:** The traditional red-rice variety, *Kalu heenati* (WF 13272) was used as the major ingredient in developing the extruded products. Rice flour, Mung bean flour, Black gram flour, Meneri flour together with cinnamon powder, sesame and black seeds were composited in developing the formulations while taking into consideration of nutrient compositions, according to the literature and ingredient percentages of other similar products available in the local market. Thus, 16 composite flour combinations were formulated fitting to the two-factor factorial experimental design and those formulations were extruded. Thereafter, samples were served to a consumer-based sensory panel (n=30) to select the best extruded samples organoleptically using 5-point hedonic scale. Sensorially best samples were subjected to proximate analysis according to the methods described by Association of Official Analytical Chemists in determining carbohydrates, fat, protein, ash, and fiber contents.

**Results:** Results revealed that four formulations were sensorially acceptable significantly as per descriptive analysis ( $p < 0.001$ ). Proximate analysis of four best extruded samples had carbohydrates, protein, fat, dietary fiber, and ash in the range of  $70.85 \pm 0.18\%$  to  $74.11 \pm 0.01\%$ ,  $19.92 \pm 0.11\%$  to  $20.94 \pm 0.01\%$ ,  $4.72 \pm 0.06\%$  to  $6.21 \pm 0.07\%$ ,  $8.92 \pm 0.02\%$  to  $9.19 \pm 0.14\%$ , and  $1.52 \pm 0.12\%$  to  $2.39 \pm 0.01\%$  respectively.

**Conclusion:** Considering the nutritional profile, the best formulation comprised with rice, green gram, black gram, meneri, black sesame, black seeds, and cinnamon, 40, 30, 15, 35, 5, 1 and 0.1 grams respectively. This formulation can be promoted as a value-added supplementary product while utilizing local grain varieties in Sri Lanka.

**Acknowledgement:** University grant number ASP/01/RE/SCI2021/93..

**PP 64**

**Knowledge and practice regarding prevention and management of anemia and influence of socio-demographics factors among antenatal mothers in Nallur MOH division**

Ahamed MIA<sup>1\*</sup>, Surenthirakumaran R<sup>2</sup>, Thabotharan D<sup>1</sup>, Nivetha K<sup>1</sup>

<sup>1</sup>Department of Nursing, Faculty of Allied Health Sciences, University of Jaffna, Sri Lanka, <sup>2</sup>Department of Community and Family Medicine, Faculty of Medicine, University of Jaffna, Sri Lanka.

**Background:** Anemia in pregnancy is a global public health burden facing the world today. Especially in the developing countries. When it occurs in pregnancy, may be associated with low birth weight and increased risk of maternal mortality/morbidity and perinatal mortality. Many studies in the past have reported the problem in high magnitude. This study aimed to emphasis the anemic awareness in Nallur, Jaffna.

**Objective:** To describe the knowledge and practice regarding prevention and management of anemia and association between socio demographic factors and knowledge about anemia among antenatal mothers.

**Methods & Materials:** This descriptive cross-sectional study carried out among 324 pregnant women. Data were collected by using a validated interviewer administered questionnaire. Data were analyzed by using and Chi-square test of socio demographic factors against knowledge on anemia. <40% score was considered poor knowledge and >70 % was considered good.

**Results:** The mean age ( $\pm$ SD) was 29 ( $\pm$ 6.19) years. Most common causative factors were lack of iron in food (76.8%). Most of them were identified with tiredness (75.8%) and pale color of the nail tongue and mucus membrane (58.0%) as common symptoms. Most known complications were low birth weight (72.8%), premature delivery (55.9%), and most known preventive measures were consume iron rich foods (83.6%), well balance diet (60.2%). 80.3% of them were identified IFA-supplementation as a treatment option. The level of knowledge regarding anemia among pregnant mothers was satisfactory 177(54.6%) and the level of practice was good (85%). Socio-demographic factors, such as, age ( $p<0.001$ ), education ( $p<0.001$ ), gestational age ( $p=0.002$ ), Gravida ( $p<0.001$ ), family type ( $p=0.003$ ), monthly income ( $p<0.001$ ) were associated with the knowledge on anemia.

**Conclusion:** The participant’s level of knowledge regarding anemia was satisfactory (40-70%) and the level of practice was good irrespective of the differences in socio demographic factors among each and every one.

**PP 65**

**Establishment and maintenance of *Aedes aegypti* (Linnaeus) mosquito colonies for vector control studies of dengue**

Dilani PVD<sup>1</sup>, Wickramasinghe PDSU<sup>1</sup>, Hapugoda M<sup>2</sup>, Silva GN<sup>1</sup>, Hettiarachchi C<sup>1</sup>, Dassanayake RS<sup>1</sup>, Gunawardene YINS<sup>2\*</sup>

<sup>1</sup>Department of Chemistry, Faculty of Science, University of Colombo, Colombo, Sri Lanka, <sup>2</sup>Molecular Medicine Unit, Faculty of Medicine, University of Kelaniya, Ragama, Sri Lanka.

**Background:** Dengue is a mosquito-borne viral disease with an estimated annual incidence of 390 million infections worldwide. Dengue control currently relies on sustainable vector control strategies. *Aedes aegypti* (Linnaeus) is the primary vector of dengue. Laboratory colonization and maintenance of *Ae. aegypti* is, therefore, a prerequisite to study their biology, behaviour and physiology.

**Objective:** To acquire authenticated, high-quality *Ae. aegypti* mosquitoes which are essential in subsequent mosquito control measures in fighting against dengue.

**Methods & Materials:** A self-mating colony was established from eggs of the F<sub>1</sub> progeny of individuals collected as free-living larvae in Ragama. Morphological identification of *Ae. aegypti* was carried out based on morphological characteristics. Standard insectary conditions and rearing procedures were followed to maintain *Ae. aegypti* colonies. Mosquitoes were reared in an insectary at 27±1°C, with a relative humidity of 75-80% and a light: dark photoperiod of 12:12. Larvae were fed with a diet of tuna meal, bovine liver powder, and brewery yeast. Adults were maintained on cattle blood with a continuous supply of 10% sugar supplements. Colony assessments were carried out for 10 successive generations by measuring: fecundity, egg hatch rate and larval mortality. The statistical significance of measured parameters among the generations was evaluated by One-way ANOVA followed by Tukey’s multiple comparison test.

**Results:** No significant differences were observed for female fecundity within the initial generations (F<sub>1</sub>-F<sub>3</sub>) (p>0.05). The fecundity increased gradually while F<sub>5</sub>-F<sub>10</sub> was comparable (p>0.05). Egg hatch rate was comparable within F<sub>1</sub>-F<sub>5</sub> (p>0.05) and no significant differences were observed within F<sub>6</sub>-F<sub>10</sub> (p>0.05). High mortality was observed at F<sub>1</sub> and F<sub>2</sub> compared to subsequent generations and no significant difference was observed within F<sub>5</sub>-F<sub>10</sub> (p>0.05).

**Conclusion:** The absence of a significant difference between F<sub>6</sub>-F<sub>10</sub> for three parameters indicates that the mosquitoes after F<sub>5</sub> are better in quality for use in subsequent vector control studies.

**Acknowledgement:** This work was financially supported by grant no 6026-LK/8743-LK of the Accelerating Higher Education Expansion and Development (AHEAD) operation.

**PP 66**

**Knowledge and its associated factors on deficiency anaemia among pregnant mothers attending antenatal clinics in selected medical officer of health areas in Colombo District**

Jayamuni NA<sup>1\*</sup>, Ranasinghe RARC<sup>1</sup>, Alahapperuma SN<sup>1</sup>, Imasha KAC<sup>1</sup>, Athukorala ACR<sup>1</sup>, Kulathilake HWCK<sup>3</sup>, Alagiyawanna AMADK<sup>2</sup>, Jayasinghe LV<sup>2</sup>, Seneviwickrama KLMD<sup>2</sup>

<sup>1</sup>Faculty of Medical Sciences, University of Sri Jayewardenepura, Sri Lanka, <sup>2</sup>Department of Community Medicine, Faculty of Medical Sciences, University of Sri Jayewardenepura, Sri Lanka, <sup>3</sup>Department of Pathology, Faculty of Medical Sciences, University of Sri Jayewardenepura, Sri Lanka.

**Background:** Anaemia is a common haematological clinical sign in pregnancy. Positive interventions to improve maternal knowledge on deficiency anemia and its preventive strategies will help to bridge the knowledge and practice gap.

**Objective:** To determine the knowledge and its associated factors on deficiency anemia among pregnant mothers attending antenatal clinics in selected MOH areas in the Colombo District.

**Methods & Materials:** A descriptive cross-sectional study was conducted using a validated, pre-tested interviewer-administered questionnaire among 180 antenatal clinic attendees in Boralesgamuwa and Piliyandala MOH areas in Colombo District selected through systematic sampling. The level of knowledge measured using a 15-item questionnaire (Possible minimum score=0, maximum score=100) later dichotomized into ‘Good’ and ‘Poor’ based on the mean of the pilot study (n=39). Factors associated with the level of knowledge were analysed by Chi-square test. The level of significance was considered as p<0.05.

**Results:** The majority belonged to 25-34 year age group (64.4%, n=116) and studied up to A/L or above (66.1%, n=119). Most of them (52.2%, n=94) had good knowledge towards deficiency anaemia. Iron deficiency anaemia was the most known form of deficiency anaemia (95.1%, n=155) followed by folate deficiency (38.0%, n=62). However, 68.7% (n=112) and 72.4%, (n=118) erroneously identified vitamin C and calcium deficiency as causes of anaemia, respectively. Monthly family income ( $X^2 = 6.714$ , df= 1, p= 0.010) and the highest level of education ( $X^2=9.376$ , df=3, p=0.025) were significantly associated with the ‘Good’ level of knowledge.

**Conclusion:** The majority had good knowledge towards deficiency anaemia. Knowledge on iron deficiency anaemia was satisfactory. Knowledge on folate and vitamin B12 was poor. There were statistically significant associations between the level of knowledge and the highest level of education and monthly family income. Effective awareness programs should be carried out in responsible healthcare institutions to raise awareness towards all types of deficiency anaemia during pregnancy.

**PP 67**

**Application of reverse transcriptase-polymerase chain reaction assay in detection of BCR-ABL1 fusion gene in suspected patients with Chronic Myelogenous Leukemia (CML)**

Herath HMNN, Basnayake BMHP, Wijeyanayake LDSR, Kugadasan M, Indrajith C, Denipitiya DTH\*  
*Molecular Diagnostics Department, Lanka Hospitals Diagnostics (pvt) Ltd, Colombo 05, Sri Lanka.*

**Background:** Chronic Myelogenous Leukemia (CML) is mainly caused by the formation of the Philadelphia (Ph) chromosome, a reciprocal translocation between chromosomes 9 and 22, resulting in the formation of the BCR-ABL1 fusion gene that encode for p210 or p190 fusion protein. The most common routine diagnostic methods, such as chromosome analysis or karyotyping have been replaced by several molecular diagnostic techniques for proper diagnosis to effective prognosis procedure.

**Objective:** We aimed to determine the frequency of detection of BCR-ABL1 gene in patients with CML by the Reverse Transcriptase-Polymerase Chain Reaction (RT-PCR) method.

**Methods & Materials:** The study was conducted with 401 peripheral blood or bone marrow samples of CML suspected patients who have been visited a selected private sector laboratory randomly from all over the country during the period of November 2018 to November 2022. RT-PCR for identifying BCR-ABL1 fusions was performed followed by RNA extraction by a commercial kit. The PCR products were analyzed by agarose gel electrophoresis. Finally, statistical analysis was performed for variant frequency identification and their comparison. Significance level was set at  $p < 0.05$ .

**Results:** Of 401 samples, 152(37.90%) were detected either to one of the gene translocations p190 or p210. Among them, 7(4.60%) were detected for p190 (e1a2) translocation and 145(95.39%) were detected for p210 (b3a2 and/or b2a2) gene translocation. Among the participants, 5(3.28%) and 85(55.92%) males were detected for p190 and p210 transcripts respectively while 2(1.31%) and 60(39.47%) females were detected for p190 and p210 transcripts respectively. There was no significant statistical difference between detection of fusion gene and male/ female ( $\chi^2 = 0.34$  and  $p = 0.56$ ).

**Conclusion:** Higher frequency p210 than p190 transcripts in the male population of CML patients but no significant statistical associations were observed between detection of fusion gene and gender.

**PP 68**

**Practice of biosafety guidelines issued during the COVID-19 pandemic in histopathology laboratories of two tertiary care centres in Colombo District**

Shafra MRF<sup>1</sup>, Jayathilaka SBSP<sup>1\*</sup>, Prematilleke IV<sup>2</sup>

<sup>1</sup>Department of Medical Laboratory Sciences, Faculty of Allied Health Sciences, University of Sri Jayewardenepura, Sri Lanka, <sup>2</sup>Department of Pathology, Faculty of Medical Sciences, University of Sri Jayewardenepura, Sri Lanka.

**Background:** Coronavirus infects both animals and humans, and produces mild to severe disease. This study investigates the adherence to the guidelines issued in Sri Lanka to histopathology laboratories by two laboratories and provides insight into items that may be optimized.

**Objective:** To investigate the extent to which the special biosafety guidelines during the COVID-19 pandemic issued by the Ministry of Health and College of Pathologists of Sri Lanka were followed in the histopathology laboratories of two laboratories of tertiary care centres in Colombo.

**Methods & Materials:** A descriptive cross-sectional study was conducted and a face validated interviewer administered questionnaire was used to collect information from all laboratory staff. Data was analyzed using SPSS version 26.

**Results:** One laboratory applied 114 of 127 precautions under nine categories, of which the most followed categories were patient handling, sample reception, fine needle aspiration cytology (FNAC) and cytology, autopsy and histopathology samples. Precautions under categories of personal protection, sample container opening and centrifuging fluids, spillages of fluid samples and waste disposal, and decontamination were not adhered to a satisfactory level. The other laboratory applied 127 of 127 precautions under ten categories, including imprint cytology and frozen sections as the final category. Histopathology samples, fine needle aspiration cytology and cytology, and waste disposal and decontamination were the most followed categories. Other categories were not adhered to a satisfactory level.

**Conclusion:** This study has shown that there are improvements that can be made to future guidelines to allow for the physical location of the laboratory and the availability of certain equipment and chemicals.

**PP 69**

**The comparison of Atherogenic Index of Plasma (AIP), Visceral Adiposity Index (VAI), Lipid Accumulation Product (LAP) between normal subjects and patients with acute myocardial infarction admitted to a tertiary care hospital, Sri Lanka**

Jayawardhana PSG<sup>1</sup>, Thathsarani SMTO<sup>1</sup>, Wijesekara GUS<sup>1\*</sup>, Bandara EMS<sup>1</sup>, Thushara Matthias<sup>2</sup>

<sup>1</sup>Department of Medical Laboratory Sciences, Faculty of Allied Health Sciences, University of Sri Jayewardenepura, Sri Lanka, <sup>2</sup>Department of Medicine, Faculty of Medical Sciences, University of Sri Jayewardenepura, Sri Lanka.

**Background:** Cardiovascular diseases are one of the major types of non-communicable diseases and cause 32% of all global deaths.

**Objective:** The aim of this study is to compare the Atherogenic Index of Plasma (AIP), the visceral adiposity index (VAI), and the Lipid Accumulation Product (LAP) between normal subjects and patients with acute Myocardial Infarction (MI) admitted to a tertiary care hospital in Sri Lanka.

**Methods & Materials:** Fifty patients with acute myocardial infarction and 50 age-matched healthy subjects between 18 and 85 years old were recruited for the study. Blood samples were drawn from patients with acute MI admitted to Colombo South Teaching Hospital within 24 hours of the onset of pain. The total cholesterol, triglycerides, Low-Density Lipoprotein (LDL), and High-Density Lipoprotein (HDL) were analyzed and used with BMI and waist circumference to calculate the above indices (VAI, AIP, and LAP). Independent sample t - test was used to compare the lipid profile parameters, AIP, VAI, and LAP values, between MI patients and healthy controls. Pearson correlation was performed to analyze the association of these indices with lipid profile parameters in patients with acute MI and in healthy subjects.

**Results:** In the study, 56% were female and 44% were male. The mean AIP (0.150), VAI (2.781), and LAP (36.594) values of patients with MI were significantly higher when compared to those values of control subjects (-0.062, 1.490, and 25.554) ( $p < 0.05$ ). The mean AIP (0.183), VAI (3.411), and LAP (44.894) values of female patients with MI were significantly higher when compared to those values of female control subjects (-0.098, 1.592, and 27.397) ( $p < 0.05$ ). It was observed that there were no significant differences in AIP, VAI, and LAP values between male patients with MI and male control subjects.

**Conclusion:** The API, VAI, and LAP can be used for the assessment of cardiovascular risk in patients, especially female subjects.

## PP 70

### **Biofilm formation and multidrug resistance of coliforms isolated from malignant patients with urinary tract infections**

Vitharana BM<sup>1</sup>, Wahalathantry DM<sup>1\*</sup>, Gunasekara TDCP<sup>2</sup>, Chathuranaga BAG<sup>1</sup>, Gunasekara SP<sup>3</sup>

<sup>1</sup>Department of Medical Laboratory Sciences, Faculty of Allied Health Sciences, University of Sri Jayewardenepura, Sri Lanka, <sup>2</sup>Department of Microbiology, Faculty of Medical Sciences, University of Sri Jayewardenepura, Sri Lanka, <sup>3</sup>Apeksha Hospital, Maharagama, Sri Lanka.

**Background:** The increase of multi drug resistant (MDR) uro-pathogenic *Enterobacteriaceae* (coliforms) is a cause for concern in cancer patients. Biofilm formation further enhances the risk in this patient population.

**Objective:** This study was conducted to determine the association between multidrug resistance and biofilm formation in bacterial pathogens of family *Enterobacteriaceae* isolated from cancer patients with urinary tract infections (UTIs).

**Methods & Materials:** An analytical cross-sectional study was conducted with 67 coliform isolates which were obtained from positive urine cultures of cancer patients during a period of 50 consecutive days. Coliform species were identified using relevant biochemical tests. Antibiotic susceptibility data of the isolates were obtained from the laboratory records. Relevant clinical data of the patients were collected from Bed Head Tickets (BHT) and other clinical records. Biofilm formation was assessed by performing Tube Method (TM) and Tissue Culture Plate (TCP) method.

**Results:** The majority of the isolates were *E. coli* (26/67, 38.8%) followed by *Klebsiella pneumoniae* (15/67, 22.4%). Approximately, 65% (n=43) of the *Enterobacteriaceae* isolates were MDR. The TM and TCP methods, respectively, identified 62.7% (43/67) of isolates and 67.2% (45/67) of isolates as biofilm formers. Biofilm-forming *Enterobacteriaceae* were significantly high among catheterized patients (20/24, 83.3%) and patients with a history of diabetes mellitus (28/36, 77.8%). *Klebsiella* spp. had a significantly high ability (21/26, 80.8%) to form biofilms. Among the biofilm formers, 64.4% (29/45) were reported as MDR. Biofilm forming bacteria showed highest sensitivity for amikacin (75.6%) whereas they were highly resistant to ampicillin (82.2%) and ciprofloxacin (77.8%).

**Conclusion:** *E. coli* and *Klebsiella* spp. were the predominant uropathogens. Biofilm formers were highly resistant to ampicillin and ciprofloxacin. Biofilm formation was not significantly associated with MDR in this study.

## PP 71

### Total phenolic and total flavonoid contents in crude boiled broth of commercially available Sri Lankan rice (*Oryzasativa L.*) varieties

Gunawardana JW<sup>1,3</sup>, Gunawardena SA<sup>2</sup>, Perera IC<sup>3</sup>, Wageesha NDA<sup>4</sup>, Witharana C<sup>1\*</sup>

<sup>1</sup>Department of Biochemistry & Molecular Biology, Faculty of Medicine, University of Colombo, Sri Lanka, <sup>2</sup>Department of Forensic Medicine & Toxicology, Faculty of Medicine, University of Colombo, Sri Lanka, <sup>3</sup>Department of Zoology & Environment Sciences, Faculty of Science, University of Colombo, Sri Lanka, <sup>4</sup>Department of Biochemistry, Faculty of Medicine, Sabaragamuwa University of Sri Lanka.

**Background:** Rice (*Oryzasativa L.*) is known to provide many nutritional benefits through biologically active phytochemicals. The crude rice extracts such as; broth or porridge are used in traditional medicine either as a nutritional supplement or for treatment.

**Objective:** To quantify and compare the total phenolic (TPC) and total flavonoid content (TFC) in boiled broth of selected commercially available rice according to variety, pericarp colour and average cooking times.

**Methods & Materials:** Husked grains (n=25) of traditional (n=4: *Suwandel, Pachchaperumal, Kaluheenati*), improved (n=20: *Kekulu (white, red), Nadu (white, red), Samba (white, red)*) and imported (n=1: *Indian-basmati*) rice varieties were cooked with 1:2.25V/V (rice:water). Boiled broth, 30 ml was collected at midpoint of each cooking cycle into high density polypropylene tubes and centrifuged (25°C/1500g/15 minutes). Triplicates of supernatant were quantified for TPC and TFC spectroscopically using Folin-Ciocalteu and Aluminium chloride assays. Results were expressed as Gallic Acid Equivalents (GAE) and Quercetin Equivalents (QE) µg/ml/100g raw rice.

**Results:** Mean (±SD) cooking time rice was 13.5 (±2.5) minutes which did not differ between the type (traditional/improved/imported) or pericarp colour (p>0.05). Non-parboiled rice needed shorter cooking time than parboiled (p<0.05). Mean (±SD) and median (IQR) TPC and TFC were 14.29 (±9.90) and 14.59 (19.96 – 6.5) GAEµg/ml and 558.11(±695.75), 468.38 (713.55 – 164.38) QEµg/ml respectively. The lowest TPC and TFC values were reported by *White-Kekulu* rice (1.53 GAEµg/ml, 71.21 QEµg/ml) while the highest was reported for *Pachchaperumal* (46.42GAEµg/ml, 3612.06µg/ml). Both TPC and TFC were higher in traditional than improved varieties (p<0.05) and red pericarp than white pericarp grains (p<0.05). The total flavonoids to phenolic ratio was 35.04 (±15.30) which was higher in traditional rice and red pericarp grains. Cooking time positively affected the TPC ( $T_b=0.45$ , p<0.05) and TFC content ( $T_b=0.40$ , p<0.05). TPC content significantly correlated with TFC in all rice varieties ( $T_b=0.70$ , p<0.01).

**Conclusion:** Significantly higher levels of phytochemicals (predominantly flavonoids) were found in boiled broth of traditional and red pericarp rice compared to white improved rice and the availability of these compounds may be enhanced by longer cooking duration.

**Acknowledgements:** Research was funded by University Research Grants (AP/3/2/2020/SG/18).

**PP 72**

**Preliminary study on fluoride exposure and associated renal health outcomes of rural children from CKDu endemic and non-endemic regions**

Wijesundara WMPA\*, De Silva HSRD, Bandara HMNN, Hasinthara GAS, Sandamini PMMA, Gunasekara TDKSC, De Silva PMCS

*Department of Zoology, University of Ruhuna, Sri Lanka.*

**Background:** High fluoride exposure is supposed to be a risk factor associated with renal injury and chronic kidney disease of unknown etiology (CKDu). Along with low priority in clinical studies, current knowledge of pediatric renal health outcomes of fluoride exposure remains incomplete.

**Objective:** The present study aimed to assess the potential effects of fluoride exposure on pediatric renal health in selected communities from CKDu endemic and non-endemic regions in Sri Lanka.

**Methods & Materials:** A cross-sectional study was conducted with 295 school students (12–16 years of age) from CKDu endemic and non-endemic regions in Padavi Sripura and Udunuwara education zones in Sri Lanka. Urinary albumin-creatinine Ratio (UACR) was used to assess renal function, considering urinary fluoride concentrations (determined with an ion-selective electrode) as a measure of fluoride exposure.

**Results:** There was no significant difference ( $p=0.575$ ) of UACR (median; interquartile range (mg/g)) between the participants in CKDu endemic (1.822; 1.106-2.935) and non-endemic (1.819; 1.253-3.388) regions. Urinary fluoride level (mg/gCr) in participants from CKDu endemic region (1.751; 1.128-2.937) was significantly higher ( $p=0.002$ ) than that of the participants from the CKDu non-endemic region (1.206; 0.838-2.083), irrespective of gender. Similarly, urinary fluoride excretion (mg/gCr) of the girls in the CKDu endemic region (2.025; 1.531-3.548) was significantly high compared to the girls in the CKDu non-endemic region (1.279; 0.846-2.122). However, no such significant difference was observed among boys. Urinary fluoride excretion of participants showed a moderate correlation ( $r=0.430$ ,  $p=0.002$ ) with ACR in CKDu endemic region, while it showed a poor correlation ( $r=0.064$ ,  $p=0.455$ ) in the CKDu non-endemic region.

**Conclusion:** High fluoride exposure with no significant difference in UACR does not produce plausibly strong evidence to explain the potential link between fluoride exposure and adverse kidney health outcomes in students. However, as UACR is a late marker of impaired renal function, detailed studies with robust biomarkers are recommended to explore these associations in depth.

**Acknowledgment:** Accelerating Higher Education Expansion and Development (AHEAD) Operation of the Ministry of Higher Education funded by the World Bank, grant number: AHEAD DOR 02/40.

**PP 73**

**A laboratory-based study for determination of cytomegalovirus infection**

Wijeyanayake LDSR, Basnayake BMHP, Herath HMNN, Kugadasan M, Indrajith C, Denipitiya DTH\*  
*Molecular Diagnostics Department, Lanka Hospitals Diagnostics (PVT) Ltd, Colombo 05, Sri Lanka.*

**Background:** Cytomegalovirus (CMV) is a ubiquitous virus that belongs to the family *Herpesviridae* and infects almost all humans at some time in their lives. Generally, the virus transmits through the contact with infected bodily fluids in humans such as organ/bone transplantation, placental pathway, sexual intercourse, blood transfusion, and direct contact with infected patients.

**Objective:** This study aimed to determine the infection of CMV in clinical specimens using the real-time Polymerase Chain Reaction (PCR) assay.

**Methods & Materials:** This study was conducted at the Molecular Diagnostic Laboratory of a selected private sector hospital from January 2015 to December 2022. A total of 768 clinical samples were received to the molecular diagnostics laboratory comprising of blood (n=737), urine (n=8), cerebrospinal fluid (n=15), bronchial wash (n=5), amniotic fluid (n=1), endotracheal secretion (n=1), and tissue (n=1). Real time PCR to detect DNA of CMV was performed followed by DNA extraction by a commercial kit.

**Results:** Of the total of 768 (715 adults and 53 children) suspected patients, 135 (17.5%) were detected by PCR for CMV infection. Of the 135 detected patients, 85 were male (62.9 %) and 50 were female (37.1%). Of the 85 male patients, 13 (15.29%) and 72 (84.71%) belonged to the age groups 1-18 years and 18-80 years respectively. Comparatively, this was 7 (14.00%) and 43 (86.00%) in female patients.

**Conclusion:** This study showed that CMV infection in male (62.9%) was higher than female (37.1%) and the infection of CMV was higher among adult population than children in both genders. The prevalence of CMV infection in this study was 17.5% which is a low value of CMV infection compared to the reports of other developing countries because this is a single - centered study.

**PP 74**

**Detection of the effects on platelet indices of COVID-19 patients at the University hospital, General Sir John Kotelawala Defence University**

Kumarasinghe RDKK<sup>1\*</sup>, Ranasinghe HN<sup>1</sup>, Jayawardana KGKG<sup>1</sup>, Kottahachchi DU<sup>1</sup>, Somaratne I<sup>2</sup>

<sup>1</sup>Department of Medical Laboratory Sciences, Faculty of Allied Health Sciences, Sir John Kotelawala Defence University, Rathmalana, Sri Lanka, <sup>2</sup>Department of Para Clinical Sciences, Faculty of Medicine, General Sir John Kotelawala Defence University, Rathmalana, Sri Lanka.

**Background:** The infection caused by SARS-COV-2 severely affected people worldwide since December 2019 by recording a high mortality rate. It still affects the mentality and day-to-day activities. Platelet Indices (PLT-IND) played a pivotal role in the management of the patients.

**Objective:** The study was aimed to find out the effects on PLT-IND of COVID-19 patients at University Hospital-KDU (UH-KDU) by establishing a correlation between platelet count (PLT) and other PLT-IND.

**Methods & Materials:** A total of 105 COVID-19 patients (Male-53.3%, Female-46.6%) between 18-80 years were selected and PLT-IND were obtained from records of UH-KDU. The data was collected from August to October 2021 and statistical analysis was performed using IBM SPSS version 21. First, correlations among each parameter were compared. Next, mean values of PLT-IND were compared between the first two days and the last two days (Day 4 and Day 5) of admission. Finally, an equation was designed for Platelet Large Cell Ratio (P-LCR) value to be calculated using PLT-IND.

**Results:** All the mean values of PLT and PLT-IND were within the reference ranges. PLT showed a significant positive correlation with Platelet Large Cell Count (P-LCC) and Plateletcrit (PCT), and negative correlation with Mean Platelet Volume (MPV), Platelet Distribution Width (PDW) and P-LCR. Only PLT, PCT, and P-LCC showed a significant mean difference on the first two days and last two days ( $p < 0.05$ ). Furthermore, an equation obtained by the regression analysis represented P-LCR by MPV ( $r = 0.901$ ,  $p < 0.05$ ).

**Conclusion:** Even though the mean values of the parameters were within reference ranges, we were able to establish correlations between PLT and PLT-IND. The equation derived;  $P-LCR = (-5.010) + 6.190 (MPV)$  suggests that there is a way of predicting P-LCR with the other PLT-IND. Further studies are needed to warrant the results.

## PP 75

### **Study of serum creatinine and uric acid in hypertensive disorders of pregnancy**

Fawaziya HLF<sup>1</sup>, Viranga AGS<sup>1</sup>, Shahmy S<sup>2</sup>, Jayawardane MAMM<sup>3</sup>, Withanage ND<sup>1\*</sup>

<sup>1</sup>Department of Medical Laboratory Sciences, Faculty of Allied Health Sciences, University of Sri Jayewardenepura, Sri Lanka, <sup>2</sup>National Science and Technology Commission, Sethsiripaya, Sri Lanka, <sup>3</sup>Department of Obstetrics and Gynaecology, Faculty of Medical Sciences, University of Sri Jayewardenepura, Sri Lanka.

**Background:** Hypertensive disorders of pregnancy are most common complications for serious morbidity, and loss of life among mothers and newborns and also increase the risk of the occurrence of cardiovascular disease, metabolic diseases, stroke, and end-stage renal disease in affected mothers. Studies have proven that levels of serum creatinine, uric acid, and estimated glomerular filtration rate (eGFR) are affected in pregnancy-related hypertensive disorders but evidences are less supportive in Sri Lankan context.

**Objective:** The present study was designed to investigate serum creatinine, uric acid, and eGFR levels in hypertensive disorders of pregnancy in a selected Sri Lankan pregnant population.

**Methods & Materials:** A case control study was conducted at Colombo South Teaching Hospital, Kalubowila with a total of sixty-two participants consisting of thirty-one normotensive pregnant women and thirty-one gestational hypertensive pregnant women, all in their third trimester singleton pregnancy. Serum creatinine, uric acid, eGFR were measured in all participants. Serum creatinine and serum uric acid levels were analysed using automated biochemistry analysers PKL PPC 125 and ABBOTT Architect C8000 respectively and eGFR was calculated using CKD-EPI equation. The relationship between the variables were estimated via binary logistic regression using SPSS software.

**Results:** Mean $\pm$ SD serum creatinine level was slightly elevated in gestational hypertensive pregnant women (0.60 $\pm$ 0.09 mg/dl) when compared to normotensive pregnant women (0.57 $\pm$ 0.06 mg/dl) which did not show significant difference among the study groups (p=0.073). Serum uric acid levels were 4.05 $\pm$ 0.75 mg/dl and 4.05 $\pm$ 0.96 mg/dl in normotensive and hypertensive pregnant women respectively (p=0.999). There was a significant difference (p=0.004) in mean eGFR value between the two study groups and eGFR values were 127.42 $\pm$ 4.99 ml/min/1.73m<sup>2</sup> and 122.26 $\pm$ 8.07 ml/min/1.73m<sup>2</sup> in normotensive and hypertensive pregnant women respectively.

**Conclusion:** Gestational hypertensive pregnant women showed significantly lower eGFR levels compared to normotensive pregnant women. Serum creatinine and uric acid did not show any significant correlation with eGFR

PP 76

## **Determination of the bacterial growth and the contamination level in reusing household plastic containers among a group of undergraduates**

Nusla MKF<sup>1</sup>, Wickrama Arachchi WANL<sup>1</sup>, Bandara AWMKK<sup>2\*</sup>, Nandapala JHYP<sup>1</sup>

<sup>1</sup>*Department of Biomedical Sciences, Faculty of Health Sciences, KAATSU International University (KIU), Sri Lanka,*

<sup>2</sup>*Department of Basic Sciences, Faculty of Allied Health Sciences, General Sir John Kotelawala Defense University, Sri Lanka.*

**Background:** Worldwide plastic containers are reused in day to day household purposes. Improper handling of plastic containers contributes many health-related complications and one of the major risks is microbial contamination.

**Objective:** The study is aimed to determine the bacterial contamination level in reusing household plastic containers among a group of undergraduates.

**Methods & Materials:** A total of 35 plastic containers reused for one to three months to store food or water were taken as the samples. The contamination level of the reusing plastic containers was evaluated by performing standard colony count to estimate the number of viable bacteria. According to the drop plate method, colony counts were recorded as colony forming units (CFU). The total colony count in each sample was categorized into <1, 1-10, 11-100, and 101-1000 CFU.

**Results:** Out of 35 samples, 26 (74.3%) samples showed positive growth of bacteria. Among these 26 samples, about 50% Gram negative bacilli, 19.23% Gram negative coco-bacilli, 15.38% Gram positive cocci, 11.54% Gram negative cocci and 3.85% Gram positive bacilli were identified respectively. According to the results, most of the CFU ranges were within 11-100 and 101-1000. Therefore, the present study revealed that there is a high contamination level of bacteria within the reused plastic containers.

**Conclusion:** The majority of reusing plastic containers were contaminated by bacteria. As a variety of bacteria has the ability to cause food and water-borne illnesses, expanded research studies are warranted to determine the association between microbial colonization and improper handling of plastics.

**PP 77**

**Association between body mass index with blood pressure and body fat percentage in undergraduates of University of Sri Jayewardenepura.**

Shamindri BHN<sup>1</sup>, Abeywickrama HN<sup>1</sup>, Perera PPR<sup>2\*</sup>

<sup>1</sup>Department of Medical Laboratory Sciences, Faculty of Allied Health Sciences, University of Sri Jayewardenepura, Sri Lanka, <sup>2</sup>Department of Biochemistry, Faculty of Medical Sciences, University of Sri Jayewardenepura, Sri Lanka.

**Background:** Hypertension is a major health problem in almost every country. In early decades it mainly affected elderly people, nowadays young adults are more affected due to sedentary life style. Body Fat Percentage (BFP) and Body Mass Index (BMI) are used to assess nutritional status of populations.

**Objective:** The study was designed to assess the association between BMI with blood pressure (BP) and BFP in undergraduates of University of Sri Jayewardenepura (USJ).

**Methods & Materials:** An analytical cross-sectional study was conducted on 182 undergraduates of USJ. BFP and height, weight were measured to calculate the BMI. BP and BFP were measured by blood pressure apparatus and Omron karadascan<sup>®</sup> analyser respectively. A pretested self-administered questionnaire was used to retrieve information and excluded who are under treatments for having chronic diseases.

**Results:** Females showed mean Systolic Blood Pressure (SBP) and Diastolic Blood Pressure (DBP) of 108.31 mmHg (SD±8.0) and 69.89 mmHg (SD±6.2) while males showed 120.98 mmHg (SD±7.7) and 75.54 mmHg (SD±8.0) respectively. Among the female population 33.33% (n=41) were underweight, 46.34% (n=57) normal weight, 8.94% (n=11) overweight and 1.62% (n=2) were obese while among males it was 15.26% (n=9), 30.50% (n=18), 20.33% (n=12) and 8.47% (n=5) respectively. Among females high, low and normal BFP were reported as 34.96% (n=43), 3.25% (n=4) and 61.78% (n=76) respectively while in males it was reported as 54.23% (n=32), 5.08% (n=3) and 40.68% (n=24) respectively. There was a positive correlation between BMI with BFP and BMI with average SBP and DBP in male, female and total population (P= 0.000)

**Conclusion:** The majority of the total study population had normal average SBP and DBP. Underweight is more common among females and overweight is more common among males. The proportion of males with high BFP was more than that of females. Considering males, females and total populations, there were significant positive correlations between average SBP and DBP with BMI and BMI with BFP.

**PP 78**

**Consumer perception on food consumption and non-communicable diseases**

Siriwardana EKDKC\*, Chandrasekhar A

*Wayamba University of Sri Lanka.*

**Background:** Non-Communicable Diseases (NCDs) accounted for 83% (2019) of all deaths in Sri Lanka, and the mortality rate has been increasing rapidly during the past decade. Individual dietary behavior depends on perceptions people have about food consumption.

**Objective:** The present study aimed to identify current consumer understandings of the inter-relationship between food consumption and NCDs.

**Methods & Materials:** A cross-sectional online survey was conducted to collect data from 160 participants of convenient sample of adults in island wide. A self-administrated online questionnaire was the instrument used to collect the data. The questionnaire was included, perception regarding NCDs such as diabetic, cardiovascular, cancer, kidney diseases and perception regarding foods.

**Results:** The majority of the sample were female, educated and young adults. Approximately 90% of participants believed that the unhealthy dietary patterns contributed to NCDs. According to the participants' understanding, 89% of them believed that a high fat diet was a major risk factor for cardiovascular diseases. Moreover, 63% of population perceived that food additives as a major risk factor for NCDs. In comparison, small number of participants only 46% and 58%, respectively, believed that low-fiber and high-carbohydrate diets were risk factors for cardiovascular disease. In addition, close to 50% of consumers did not have a clear understanding regarding daily serving recommendations of fruits and vegetables. Most participants (51%) perceived that all types of margarine and fat spreads were bad for cardiovascular health. Additionally, people perceived a busy lifestyle and a lack of knowledge about healthy eating as extreme barriers to healthy eating.

**Conclusion:** The participants in the study sample correctly perceived that unhealthy eating habits cause NCDs and following a healthier diet and lifestyle would be an effective approach to reducing the burden. However, their knowledge on fat types in general, fruit and vegetable recommendations were not at a satisfactory level.

**PP 79**

**Association among serum uric acid and microalbuminuria in type 2 diabetic patients attending diabetic center at Teaching Hospital, Jaffna.**

Kayathri V<sup>1</sup>, Kinthuja N<sup>1</sup>, Abirami M<sup>1</sup>, Kesavan V<sup>2</sup>, Aravindan M<sup>3</sup>, Jaikrishna B<sup>1</sup>

<sup>1</sup>Department of Medical Laboratory Sciences, Faculty of Allied Health Sciences, University of Jaffna, Sri Lanka, <sup>2</sup>Department of Chemical Pathology, Teaching Hospital, Jaffna, Sri Lanka, <sup>3</sup>Diabetic Centre, Teaching Hospital, Jaffna, Sri Lanka.

**Background:** Type 2 diabetes mellitus is a chronic metabolic disorder, which leads to diabetic complications which may result in End-Stage Renal Disease (ESRD). Uric acid acts as an oxidant, inducing oxidative stress and endothelial dysfunction. Even though the role of uric acid as a marker of diabetic nephropathy has been documented in many western studies, the literature on the topic is limited. Microalbuminuria is a component of the metabolic syndrome characterized by insulin resistance and a sign of the final stage in which renal damage can be repaired.

**Objective:** The study was aimed to evaluate the association between serum uric acid and urine albumin creatinine ratio in type 2 diabetes mellitus patients at Teaching Hospital Jaffna.

**Methods & Materials:** This was a hospital-based study conducted at Diabetic Centre, Teaching Hospital, Jaffna. A total of 119 patients were included. Two milliliters of venous blood samples were collected. Serum uric acid and urine albumin creatinine ratio were measured by uricase peroxidase coupled reaction method and Particle- Enhanced Turbidimetric Inhibition Immunoassay (PETINIA) respectively. SPSS version 25 was used for the analysis of data. The strength of the correlation was determined by Kendall's tau b correlation.

**Results:** Among 119 participants, 44 were males (36.9%) and 75 were females (63.1%). Mean serum uric acid level of total population was 6.405 ( $\pm 1.87$ ) mg/dl. The correlation between serum uric acid and urine albumin creatinine ratio showed a weak positive correlation which was statistically significant ( $r=0.232$ ,  $p<0.01$ ,  $n=14$ ).

**Conclusion:** A statistically significant weak positive correlation between serum uric acid and urine albumin creatinine ratio suggests that there may be some other factors influencing the correlation among these parameters. Micro-albuminuria monitoring and serum uric acid monitoring with better management may delay diabetic nephropathy.

**PP 80**

**Attitudes and perception towards body image concerns and eating practices among students at a selected educational institute, Gampaha District, Sri Lanka**

Seneviratne DBR<sup>1\*</sup>, Kaldera HPSR<sup>2</sup>

<sup>1</sup>*School of Biomedical Sciences, International Institute of Health Sciences, Welisara, Sri Lanka*, <sup>2</sup>*School of Nursing, International Institute of Health Sciences, Welisara, Sri Lanka*.

**Background:** Body image concern is the dynamic perception of an individual which correlates with eating habits. Concerns about body image has been rising recently and affects people of all ages, mainly the youth.

**Objective:** This study was conducted to explore the perception of body image concerns and eating practices among students and to identify the attitudes regarding this rising social issue.

**Methods & Materials:** A descriptive, cross-sectional study design was followed. A convenient sampling method was used to select 100 participants who were over 16 years. Data was collected using a pre tested self-administered questionnaire and was analyzed using Microsoft Excel software.

**Results:** The study revealed that 74% were females and the age category of 19-21 years represented the highest number of participants which was 44%. A significant number (52%) stated that they viewed their body image at a satisfactory level. Further, 58% expressed that they compared their body shape with others and of them, 34% indicated that it is with public figures. A notable amount (68%) stated that they attempted to change their body shape and of them, 52% specified that they reduce meals and engage in sports and exercise for that. Moreover, 48% declared that they have been criticized because of their body shape. Additionally, 56% agreed that it is normal to worry about body shape. Generality (76%) accepted that counselling should be recommended for individuals engaging in unhealthy methods to control weight. The majority (58%) disagreed with the expression that it is uncomfortable to view themselves in the mirror.

**Conclusion:** It was concluded that the participants had varying views about body image concerns and eating practices. Most were aware of unhealthy practices used to control weight. This study further affirmed that body image concerns play a major role on eating habits of the younger population.

## **PP 81**

### **Clinical manifestation of COVID-19 and the association of vital body parameters with chronic diseases and vaccination among infected patients**

Rathnakumara MPB<sup>1</sup>, Gunarathne RTM<sup>1</sup>, Dayananda RGTN<sup>1</sup>, Sasithanjali MVM<sup>1</sup>, Indrachapa DM<sup>1</sup>, Perera KSA<sup>2</sup>, Samarana HMVA<sup>2\*</sup>, Nisansala MWN<sup>1</sup>, Senarath NSASN<sup>1</sup>

<sup>1</sup>Department of Nursing, Faculty of Nursing, KAATSU International University (KIU), Sri Lanka, <sup>2</sup>Department of Medical Science in Acupuncture, Faculty of Health Sciences, KAATSU International University (KIU), Sri Lanka.

**Background:** Around six million individuals died from COVID-19. Clinical manifestations ranged from asymptomatic or mild symptoms to severe illness and mortality. COVID-19 is aggravated by chronic diseases. Morbidity and mortality are reduced by widespread vaccination.

**Objective:** To investigate the clinical manifestations of COVID-19 and the association of vital body parameters with vaccination and chronic diseases in COVID-19 infected patients admitted to the Infectious Disease Hospital (IDH) in Sri Lanka.

**Methods & Materials:** A cross-sectional study was conducted from January to March, 2022 at IDH Sri Lanka with 170 patient medical records confirmed with COVID-19. A simple random sampling approach and a researcher-developed data extraction sheet containing clinical manifestations of COVID-19, vital body parameters, vaccination status, and the presence of chronic diseases was used. SPSS 25 was used for data analysis. KIU Ethics Review Committee granted ethical approval.

**Results:** The mean age of the sample was  $40.62 \pm 17.93$  years, and the majority 103 (60.60%) consisted of males. Headaches, fatigue, cough, and body aches were the most prevalent clinical symptoms upon admission in 166 (97.6%), 162 (95.3%), 160 (94.1%), and 150 (88.2%) of patients respectively. Meanwhile, 30 (17.6%), 12 (7.1%), and 38 (22.4%) of patients had shortness of breath, diarrhea, and sore throat respectively. The majority of the population 164 (96.5%) has been vaccinated against COVID-19 with both the 1<sup>st</sup> and 2<sup>nd</sup> doses, and 98 (60%) of the vaccinated patients has received a 3<sup>rd</sup> dose. Chronic diseases affected 41 (24.12%) of the participants. Of the patients, 15 (8.8%) had a temperature above 100.4 °F, 55 (32.4%) had oxygen saturation levels below 95%, 10 (5.9%) had respiratory rate > 16 breaths/min, and 13 (7.8%) had heart rate greater than 100 bpm. Elevated body temperature and tachycardia were not linked with chronic medical conditions or vaccination status ( $p > 0.05$ ). Low O<sub>2</sub> saturation and high respiratory rate were associated with chronic conditions and not receiving the 3<sup>rd</sup> COVID-19 dose ( $p < 0.001$ ).

**Conclusion:** Headache, fatigue, body aches, and cough were prevalent clinical manifestations of COVID-19. Low O<sub>2</sub> saturation and increased respiratory rate were associated with chronic medical conditions and not receiving the 3<sup>rd</sup> vaccine dose.

**PP 82**

**Explore the effect of fist clenching during blood collection in the measurement of serum calcium**

Vathsala S<sup>1\*</sup>, Vibeeshan T<sup>1</sup>, Umasuthan U<sup>1</sup>, Balakittnen J<sup>1</sup>, Sivakumar H<sup>2</sup>

<sup>1</sup>Department of Medical Laboratory Sciences, Faculty of Allied Health Sciences, University of Jaffna, Sri Lanka, <sup>2</sup>Department of Pathology, Faculty of Medicine, University of Jaffna, Sri Lanka.

**Background:** In clinical laboratory, calcium is the most routinely tested analyte, because it plays an important role in body homeostasis. Repeated fist clenching and maintaining either with or without the application of a tourniquet is one of the pre-analytical errors resulting insignificant bias and can notably influence patient care.

**Objective:** The study aimed to explore the effect of fist clenching during blood collection in the measurement of serum calcium of healthy individuals at the Faculty of Allied Health Sciences, University of Jaffna.

**Methods & Materials:** A total of 56 paired blood samples were collected from healthy individuals at the Faculty of Allied Health Sciences, University of Jaffna. A volume of 2.5 ml blood was collected each from an arm without and with fist clenching within 5 minutes from the same vein. Serum total calcium concentration was measured by Arsenazo III method and data was analyzed using paired t-test.

**Results:** Among the total population, 32 were females and 24 were males. Serum calcium level of total participants without and with fist clenching ranged between 7.84- 12.86 [9.55 ( $\pm 1.1$ )] mg/dl and 9.84- 14.96 [11.46 ( $\pm 1.1$ )] mg/dl respectively. The mean of serum calcium level of male participants without and with fist clenching were 9.73 ( $\pm 1.3$ ) mg/dl and 11.74 ( $\pm 1.1$ ) mg/dl respectively. The mean of serum calcium level of female participants without and with fist clenching were 9.43 ( $\pm 0.9$ ) mg/dl and 11.26 ( $\pm 1.0$ ) mg/dl respectively. The mean percentage difference was 16.67% and it was statistically significant ( $p < 0.001$ ).

**Conclusion:** This study findings supports the fist clenching and maintaining it during the blood collection led to falsely elevated levels in serum calcium. Therefore its maintenance should be avoided during the collection of blood specimens by venipuncture in order to obtain accurate and clinically reliable serum calcium levels.

**PP 83**

**An evaluation of adulteration in chili powder sold in shops in the Peliyagoda urban council area**

Pushpakumara PAYN<sup>1\*</sup>, Gunawardhana VSS<sup>1</sup>, Tharaka MGGS<sup>1</sup>, Paranawithana SND<sup>1</sup>, Rajendran MR<sup>1</sup>, Samarakoon N<sup>1</sup>, Jayawickrama DR<sup>2</sup>

<sup>1</sup>Department of Biomedical Science, Faculty of Health science, KAATSU International University (KIU), Sri Lanka,

<sup>2</sup>Department of Animal Science, Faculty of Animal Science and Export Agriculture, Uva Wellassa University of Sri Lanka, Sri Lanka.

**Background:** The food adulteration is defined as “Addition of the non-food items to increase the quantity of the food items in raw or prepared form, preservation purpose and improvement of appearance”. Such foods can lead to different health problems after consumption like asthma, skin diseases and cancers.

**Objective:** The study aimed to identify the chili powder adulteration methods and prevalence of chili powder sold in shops of Peliyagoda urban council area.

**Methods & Materials:** Analytical cross-sectional study was conducted for chili powder samples from total 79 shops from Peliyagoda urban council area. Among them, 59 shops carry branded products while rest of the 20 proceeds sales with the non-branded samples. Grittiness evolution method identified the presence of brick powder/sand and white particle detection method identify the other debris were used as physical methods for the study. Our chili powder sample has been contaminated with starch and calcium salt. It was detected using iodine test and HCl respectively.

**Results:** In physical testing, among branded samples, 79.66% (47/59) presented with grittiness. While 33.89% (20/59) presented with white particles. Among non-branded samples, all products showed grittiness and white particles. However, during chemical testing, all branded samples were not contaminated with starch and calcium salt. Ninety-five percent (19/20) of non-branded samples were detected with starch but, not with calcium salt.

**Conclusion:** This study reveals that, chili powder being sold in the Peliyagoda urban council area is comparatively adulterated. The majority of the branded and non-branded samples showed the presence of brick powder/sand and debris. Furthermore, the majority of the non-branded samples showed starch. While all the branded and non-branded samples were negative for calcium. We suggest that futures research works may find out ingredients which is used as adulterants and their quantities.

**PP 84**

**Knowledge of street food safety among the students in a private university in Colombo, Sri Lanka**

Kodikara VS, De Silva RM, Nandapala JHYP, Ranadeva NDK

*Department of Biomedical Science, Faculty of Health Sciences, KAATSU International University (KIU), Sri Lanka.*

**Background:** Lack of knowledge about street food safety is one of the main concerns among undergraduates. Many studies have reported that university students have inadequate knowledge about street food safety which put their health at risk from food borne diseases.

**Objective:** Determine the knowledge of street food safety among a selected group of undergraduates in Colombo, Sri Lanka.

**Methods & Materials:** A pretested self-administered questionnaire was designed to collect data from the participants. Three hundred and thirty-two (332) consumers voluntarily participated to the study. The data were analyzed using IBM SPSS version 26 and statistical significance was assessed using the Chi-square test with the cutoff point for statistical significance set at  $p < 0.05$ . Numerical data were analyzed using descriptive statistics and categorical data were analyzed using frequencies. For total knowledge score calculation, a score of less than 22 was considered to indicate a low level of food safety knowledge, 22-35 denoted a satisfactory level, and more than 35 was considered good.

**Results:** The study revealed that the majority of consumers (89.5%) had average knowledge level on street food safety. Socio-demographic factors did not have a significant effect on the level of food safety knowledge of the consumers ( $p = 0.211$ ). No significant difference was observed between the knowledge levels of males and females ( $p = 0.267$ ). The majority of consumers (91.1% males and 90% females) were aware of the risk of food contamination, the importance of washing hands and proper sanitation with regards to the prevention of foodborne diseases.

**Conclusion:** As the majority of consumers had average food safety knowledge, continuous education is necessary to increase the awareness among young adults; as they will be the next generation who will be directly handling food, and will play an important role to maintain a hygienic and clean environment.

## PP 85

### Anticandidal activity of antimicrobial peptide “Octominin” encapsulated chitosan nanoparticles

Jayathilaka EHTT, Nikapitiya CL, Wang P, De Zoysa M\*

College of Veterinary Medicine and Research Institute of Veterinary Medicine, Chungnam National University, Daejeon 34134, Republic of Korea, <sup>2</sup>National Marine Biodiversity Institute of Korea (MABIK), Seochun-gun, 33662, Republic of Korea.

**Background:** Antimicrobial peptides (AMPs) are short chain of peptide that widely exist in nature, and they are important in controlling wide range of pathogens (bacteria, virus and fungi). Encapsulation AMPs into chitosan nanoparticles (CNPs) was developed as an efficient target drug delivery system to improve the stability of AMPs and to reduce toxicity toward the host.

**Objective:** In this study, we encapsulated the AMP, Octominin into CNPs and evaluated its physiochemical characteristics and its antifungal activity against *Candida albicans*.

**Methods & Materials:** Octominin was encapsulated into CNPs by ionotropic gelation in the presence of carboxymethyl chitosan. Characterization of Octominin-encapsulated chitosan nanoparticles (Octominin-CNPs) was conducted by particle size and zeta potential analysis, encapsulation efficiency (EE%) and, loading capacity (LC%) determination, transmission electron microscopic analysis, and cumulative peptide release profiling. Octominin-CNPs antifungal activity against *C. albicans* was compared against Octominin in time-kill kinetic and bacterial viability reduction assays. Furthermore, morphological alterations, membrane permeability alteration, reactive oxygen species (ROS) generation, and biofilm inhibition and eradication assays were conducted to compare the intensity of the modes of action.

**Results:** Average diameter and zeta potential of Octominin-CNPs were  $372.80 \pm 2.31$  nm and  $+51.23 \pm 0.38$  mV, respectively, while EE% and LC% were 96.49 and 40.20%, respectively. Octominin-CNPs showed an initial rapid and later sustained biphasic release profile, up to  $88.26 \pm 3.26\%$  of the total Octominin release until 96 h. TEM analysis showed the irregular shape of the Octominin-CNPs with aggregations. Octominin-CNPs showed significant ( $p < 0.001$ ) anticandidal activity against *C. albicans*. Furthermore, Octominin-CNPs treated *C. albicans* illustrated higher levels of morphological alterations, cell membrane permeability alterations, reactive oxygen species generation, and significant ( $p < 0.001$ ) antibiofilm activity.

**Conclusion:** Octominin was successfully encapsulated into CNPs, and Octominin-CNPs showed greater antifungal activity against *C. albicans* compared to Octominin.

**Acknowledgment:** This research was supported by the Research Program of the National Marine Biodiversity Institute of Korea (MABIK2022M00400), funded by the Ministry of Oceans and Fisheries, and by the National Research Foundation of Korea (NRF) grants funded by the Korean government (MSIT) (2018R1A2B6007841 and 2019R1A2C1087028).

PP 86

**Immune modulatory activity of exosomes isolated from *Streptococcus parauberis* infected olive flounder (*Paralichthys olivaceus*) plasma**

Jayathilaka EHTT, De Zoysa M, Nikapitiya C\*

College of Veterinary Medicine and Research Institute of Veterinary Medicine, Chungnam National University, Daejeon 34134, Republic of Korea.

**Background:** Exosomes are a group of extracellular vesicles containing DNA, RNA, proteins, and lipids. They have been highly incorporated for therapeutic and diagnostic applications in the medical field.

**Objective:** We isolated exosomes from *Streptococcus parauberis* infected and non-infected olive flounder (*Paralichthys olivaceus*) plasma and compared the *in vitro* and *in vivo* immune modulation activity.

**Methods & Materials:** Olive flounder fish were challenged intraperitoneally with *S. parauberis* (Gram +ve bacteria) and exosomes (Sp-Exo) were isolated from the plasma. Similarly, exosomes (PBS-Exo) were isolated from the PBS injected fish plasma (control). Both exosomes were characterized using nano-tracking analysis, transmission electron microscopy (TEM), and immunoblotting. Gene expression patterns of fat head minnow (FHM) and Raw 264.7 cells, treated with Sp-Exo and PBS-Exo were tested by qRT-PCR analysis. *In vivo* immune modulatory activity was compared between Sp-Exo and PBS-Exo using zebrafish larvae by mRNA expression and relative percent survival (RPS) upon *S. parauberis* infection. All the experiments were conducted in triplicates and one-way ANOVA was used for the determination of significant differences at 0.05 significance level.

**Results:** Average particle diameter and concentration of Sp-Exo were  $113.1 \pm 9.3$  nm and  $1.27 \times 10^{10}$  particles/ml, respectively and PBS-Exo were  $120.5 \pm 6.1$  nm and  $6.98 \times 10^9$  particles/ml, respectively. Both Sp-Exo and PBS-Exo morphology had unique cup shape and membrane bound clear margins. Immunoblot analysis showed isolated exosomes contain the main exosome markers (CD63, CD9, and CD81) and the absence of albumin. Sp-Exo-treated FHM and Raw 264.7 cells showed higher *in vitro* immune modulatory activity compared to the PBS-Exo. Sp-Exo-treated zebrafish larvae also showed a higher immune gene expression with induced immune cytokines. RPS of *S. parauberis* challenged zebrafish larvae was significantly ( $p < 0.05$ ) higher in Sp-Exo treated group (80%) than PBS-Exo treated group (30.76%).

**Conclusion:** Sp-Exo showed significantly higher immune modulatory activity and a higher protection against *S. parauberis* infected zebrafish larvae.

**Acknowledgment:** This work was supported by the National Research Foundation of Korea (NRF) grants, funded by the Korea government (MSIT) (2021R1A2C1004431).

## Oral Presentations

| International Research Conference in Health Sciences 2023 (IRCHS 2023) |       |                                                                                                                                                                                                                                                                                                                                                                                                                                                                                                                                                                                                                                                                                                                                                                      |
|------------------------------------------------------------------------|-------|----------------------------------------------------------------------------------------------------------------------------------------------------------------------------------------------------------------------------------------------------------------------------------------------------------------------------------------------------------------------------------------------------------------------------------------------------------------------------------------------------------------------------------------------------------------------------------------------------------------------------------------------------------------------------------------------------------------------------------------------------------------------|
| SN                                                                     | OP ID | Title                                                                                                                                                                                                                                                                                                                                                                                                                                                                                                                                                                                                                                                                                                                                                                |
| <b>Session I - Nursing, Management &amp; Health Promotion</b>          |       |                                                                                                                                                                                                                                                                                                                                                                                                                                                                                                                                                                                                                                                                                                                                                                      |
| 1.                                                                     | OP 1  | <p><b>Cultural adaptation and validation of Sinhala version of Frail Non-Disabled Tool: a pilot study to compare with gold standard Fried phenotype</b></p> <p>Silva FHDS<sup>1*</sup>, Ramadasa GU<sup>2</sup>, Perera S<sup>1</sup>, Ganhewa G<sup>1</sup>, Perera GLSN<sup>3</sup>, Lekamwasam S<sup>4</sup></p> <p><sup>1</sup>Department of Medicine, Faculty of Medical Sciences, University of Sri Jayewardenepura, Sri Lanka, <sup>2</sup>Department of Medicine, Faculty of Medicine, Sabaragamuwa University of Sri Lanka, Sri Lanka, <sup>3</sup>National Cancer Control Programme, Sri Lanka, <sup>4</sup>Department of Medicine, Faculty of Medicine, University of Ruhuna, Sri Lanka.</p>                                                              |
| 2.                                                                     | OP 2  | <p><b>Awareness, attitudes, and perceived skillfulness towards telehealth and telenursing among nurses in a selected hospital, Sri Lanka</b></p> <p>Dilhani PDO<sup>1*</sup>, Ilankoon IMPS<sup>2</sup></p> <p><sup>1</sup>National Hospital of Sri Lanka (NHSL), Sri Lanka, <sup>2</sup>Department of Nursing and Midwifery, Faculty of Allied Health Sciences, University of Sri Jayewardenepura, Sri Lanka.</p>                                                                                                                                                                                                                                                                                                                                                   |
| 3.                                                                     | OP 3  | <p><b>Knowledge and attitudes on postpartum depression among family members of pregnant women attending antenatal clinics in Rathnapura and Colombo districts</b></p> <p>Wanigasooriya SLDPA<sup>1*</sup>, Mirshan S<sup>1</sup>, Ranasinghe RARC<sup>1</sup>, Gunawardana ADIN<sup>1</sup>, Wickramaarachchi KWIU<sup>1</sup>, Shiyam A<sup>2</sup>, Seneviratne Alles SMP<sup>3</sup>, Seneviwickrama KLMD<sup>2</sup></p> <p><sup>1</sup>Faculty of Medical Sciences, University of Sri Jayewardenepura, Sri Lanka, <sup>2</sup>Department of Community Medicine, Faculty of Medical Sciences, University of Sri Jayewardenepura, Sri Lanka, <sup>3</sup>Department of Psychiatry, Faculty of Medical Sciences, University of Sri Jayewardenepura, Sri Lanka.</p> |
| 4.                                                                     | OP 4  | <p><b>Nurses' awareness on legal aspects related to nursing regulation and associated factors in a selected teaching hospital, Sri Lanka</b></p> <p>Herath HMSN<sup>1*</sup>, Seneviratne SMKS<sup>2</sup></p> <p><sup>1</sup>Colombo South Teaching Hospital, Sri Lanka, <sup>2</sup> Department of Nursing and Midwifery, Faculty of Allied Health Sciences, University of Sri Jayewardenepura, Sri Lanka.</p>                                                                                                                                                                                                                                                                                                                                                     |
| 5.                                                                     | OP 5  | <p><b>Learning styles and their associated factors among medical undergraduates of 2018/2019 intake in selected Medical faculties in Sri Lanka</b></p> <p>Kumarasinghe WMM<sup>1*</sup>, Wijeratne DC<sup>1</sup>, Caldera HSD<sup>1</sup>, Silva NHK<sup>1</sup>, Ranasinghe BAHP<sup>1</sup>, Hettiaratchi UPK<sup>2</sup>, Shiyam A<sup>3</sup>, Seneviwickrama KLMD<sup>3</sup></p>                                                                                                                                                                                                                                                                                                                                                                              |

|                                                                           |              |                                                                                                                                                                                                                                                                                                                                                                                                                                                                                                                                                                                                                                                                                                                                                                                        |
|---------------------------------------------------------------------------|--------------|----------------------------------------------------------------------------------------------------------------------------------------------------------------------------------------------------------------------------------------------------------------------------------------------------------------------------------------------------------------------------------------------------------------------------------------------------------------------------------------------------------------------------------------------------------------------------------------------------------------------------------------------------------------------------------------------------------------------------------------------------------------------------------------|
|                                                                           |              | <sup>1</sup> Faculty of Medical Sciences, University of Sri Jayewardenepura, Sri Lanka, <sup>2</sup> Department of Biochemistry, Faculty of Medical Sciences, University of Sri Jayewardenepura, Sri Lanka, <sup>3</sup> Department of Community Medicine, Faculty of Medical Sciences, University of Sri Jayewardenepura, Sri Lanka.                                                                                                                                                                                                                                                                                                                                                                                                                                                  |
| <b>Session II - Discovery, Development &amp; Quality use of Medicines</b> |              |                                                                                                                                                                                                                                                                                                                                                                                                                                                                                                                                                                                                                                                                                                                                                                                        |
| 6.                                                                        | <b>OP 12</b> | <b>Assessment of ability of caregivers to determine liquid paracetamol doses for infants</b><br>Samarasekara KP <sup>DN*</sup> , Karunanayaka KDSV, Prasadi GAM<br><i>Department of Pharmacy, Faculty of Allied Health Sciences, University of Ruhuna, Sri Lanka.</i>                                                                                                                                                                                                                                                                                                                                                                                                                                                                                                                  |
| 7.                                                                        | <b>OP 13</b> | <b>Formulation of polyherbal foot care cream for cracked heels using selected medicinal plant extracts and <i>in-vitro</i> evaluation of antibacterial and antioxidant activities</b><br>Wimalarathna SMMR <sup>K*</sup> , Hettihewa SK, Dissanayake AS<br><i>Department of Pharmacy, Faculty of Allied Health Sciences, University of Ruhuna, Galle, Sri Lanka.</i>                                                                                                                                                                                                                                                                                                                                                                                                                   |
| 8.                                                                        | <b>OP 14</b> | <b>Comparison of medication safety practices in pharmacies of government hospitals and private sector pharmacies for the development of a medication safety practice package for pharmacists in Sri Lanka</b><br>Bandara GRWSK <sup>1,2*</sup> , Samaranyake D <sup>3</sup> , Samaranyake NR <sup>4</sup> , Galappaththy P <sup>1</sup><br><i><sup>1</sup>Department of Pharmacology, Faculty of Medicine, University of Colombo, Sri Lanka, <sup>2</sup>Ministry of Health, Nutrition &amp; Indigenous Medicine, Sri Lanka, <sup>3</sup>Department of Community Medicine, Faculty of Medicine, University of Colombo, Sri Lanka, <sup>4</sup>Department of Pharmacy and Pharmaceutical Sciences, Faculty of Allied Health Sciences, University of Sri Jayewardenepura, Sri Lanka.</i> |
| 9.                                                                        | <b>OP 15</b> | <b>Antiglycation properties of aqueous extracts from selected plant species: An <i>invitro</i> study</b><br>Senevirathne NHMVN <sup>1*</sup> , Perera HKI <sup>2</sup> , Mendis BEP <sup>1</sup> , Rajapakse RPNP <sup>1</sup> , Weerapperuma TMKBB <sup>2</sup><br><i><sup>1</sup>Department of Food Science and Technology, University of Peradeniya, Sri Lanka, <sup>2</sup>Department of Biochemistry, Faculty of Medicine, University of Peradeniya, Sri Lanka.</i>                                                                                                                                                                                                                                                                                                               |
| 10.                                                                       | <b>OP 16</b> | <b>Suggested improvements for residential drug rehabilitation in Sri Lanka, perception of experts and professionals in the field of substance abuse treatment</b><br>Dharmarathna HHND <sup>1,5*</sup> , Jayamaha AR <sup>2</sup> , Rajapakse IH <sup>3</sup> , Gunasekara C <sup>4</sup> , Fernando N <sup>4</sup> , Meegoda MKDL <sup>5</sup><br><i><sup>1</sup>Faculty of Nursing, KAATSU International University (KIU), Sri Lanka, <sup>2</sup>Faculty of Graduate Studies, KAATSU International University (KIU), Sri Lanka, <sup>3</sup>Faculty of Medicine, University of Ruhuna, Sri Lanka, <sup>4</sup>Faculty of Medical Sciences, University of Sri Jayewardenepura, Sri Lanka, <sup>5</sup>Faculty of Health Sciences, University of Sri Jayewardenepura, Sri Lanka.</i>  |
| <b>Session III - Health, Nutrition &amp; Laboratory Diagnostics</b>       |              |                                                                                                                                                                                                                                                                                                                                                                                                                                                                                                                                                                                                                                                                                                                                                                                        |
| 11.                                                                       | <b>OP 24</b> | <b>Molecular characterization of environmental <i>Leptospira</i> isolated from selected areas of Rathnapura district, Sri Lanka</b><br>Wanigarathna GUS <sup>1</sup> , Herath T <sup>2</sup> , Rathnayake NS <sup>2</sup> , Bandara RMVV <sup>2</sup> , Vijeyakumaran R <sup>2</sup> , Karunadasa AKU <sup>2</sup> , Gamage CD <sup>2*</sup><br><i><sup>1</sup>Department of Medical Laboratory Science, Faculty of Allied Health Sciences, University of Peradeniya, Sri Lanka, <sup>2</sup>Department of Microbiology, Faculty of Medicine, University of Peradeniya, Sri Lanka.</i>                                                                                                                                                                                                 |
| 12.                                                                       | <b>OP 26</b> | <b>COVID-19 chest computed tomography to detect and stratify severity score using computer aided detection system</b><br>Chandrasiri NR <sup>*</sup> , Kulatunga S<br><i>Department of Radiography/ Radiotherapy, Faculty of Allied Health Sciences, University of Peradeniya, Sri Lanka.</i>                                                                                                                                                                                                                                                                                                                                                                                                                                                                                          |

|                                                                |       |                                                                                                                                                                                                                                                                                                                                                                                                                                                                                                                                                                                                                                                                                                                                                                                                                                                                                                                                         |
|----------------------------------------------------------------|-------|-----------------------------------------------------------------------------------------------------------------------------------------------------------------------------------------------------------------------------------------------------------------------------------------------------------------------------------------------------------------------------------------------------------------------------------------------------------------------------------------------------------------------------------------------------------------------------------------------------------------------------------------------------------------------------------------------------------------------------------------------------------------------------------------------------------------------------------------------------------------------------------------------------------------------------------------|
| 13.                                                            | OP 27 | <b>Development of herbal green tea products with fruit of <i>Annona muricata</i> (Katu anoda) and <i>Invitro</i> evaluation</b><br><u>Madhushani KLG*</u> , Hettihewa SK<br><i>Department of Pharmacy, Faculty of Allied Health Sciences, University of Ruhuna, Sri Lanka.</i>                                                                                                                                                                                                                                                                                                                                                                                                                                                                                                                                                                                                                                                          |
| 14.                                                            | OP 28 | <b>Identification of biofilm forming uropathogens in patients’ urinary catheters and analysis of their exopolymer matrix</b><br><u>Maduwanthi TLM<sup>1</sup></u> , Perera GCMK <sup>1</sup> , Nissanka NMC <sup>2,5</sup> , Wijesinghe GK <sup>3</sup> , Weerasekara DD <sup>4</sup> , Weerasekera MM <sup>2</sup> , Dilhari KAA <sup>5*</sup><br><i><sup>1</sup>Department of Medical Laboratory Sciences, Faculty of Allied Health Sciences, University of Sri Jayewardenepura, Sri Lanka, <sup>2</sup>Department of Microbiology, Faculty of Medical Sciences, University of Sri Jayewardenepura, Sri Lanka, <sup>3</sup>Bristol Dental School, University of Bristol, United Kingdom, <sup>4</sup>Department of surgery, Faculty of Medical Sciences, University of Sri Jayewardenepura, Sri Lanka, <sup>5</sup>Department of Basic Sciences, Faculty of Allied Health Sciences, University of Sri Jayewardenepura, Sri Lanka.</i> |
| <b>Session IV - Nursing, Management &amp; Health Promotion</b> |       |                                                                                                                                                                                                                                                                                                                                                                                                                                                                                                                                                                                                                                                                                                                                                                                                                                                                                                                                         |
| 15.                                                            | OP 6  | <b>Relationship between non-communicable diseases and musculoskeletal pain among computer-using office workers in selected Regional Secretariat Offices</b><br><u>Jinadasa PPDN<sup>1*</sup></u> , Mathangasinghe Y <sup>2</sup> , Perera RS <sup>3</sup><br><i><sup>1</sup>Department of Allied Health Sciences, Faculty of Medicine, University of Colombo, Sri Lanka, <sup>2</sup>Department of Anatomy Genetics and Biomedical Informatics, Faculty of Medicine, University of Colombo, Sri Lanka, <sup>3</sup>Department of Cell and Developmental Biology, Biosciences Division, University College London, United Kingdom.</i>                                                                                                                                                                                                                                                                                                   |
| 16.                                                            | OP 7  | <b>Effect of sperm parameters on success rate of Intra Uterine Insemination among couples attending a selected fertility care center in Colombo District.</b><br><u>Gunathilaka RH<sup>1</sup></u> , Kumara HBBH <sup>1</sup> , Akalanka HMK <sup>2*</sup> , Rajapaksa A <sup>3</sup><br><i><sup>1</sup>Department of Medical Laboratory Sciences, Faculty of Allied Health Sciences, University of Sri Jayewardenepura, Sri Lanka, <sup>2</sup>Department of Basic Sciences, University of Sri Jayewardenepura, Sri Lanka, <sup>3</sup>Suvika Fertility Centre, Nugegoda, Sri Lanka.</i>                                                                                                                                                                                                                                                                                                                                               |
| 17.                                                            | OP 8  | <b>Maternity care providers’ perceptions on the quality of intrapartum care: An exploratory descriptive qualitative study in Teaching Hospital Peradeniya</b><br><u>Weerasingha BRGTK<sup>1*</sup></u> , Abeyrathne RM <sup>2</sup> , Tennakoon S <sup>3</sup> , Ratnayake RMCJ <sup>1</sup><br><i><sup>1</sup>Department of Obstetrics and Gynecology, Faculty of Medicine, University of Peradeniya, Sri Lanka, <sup>2</sup>Department of Sociology, Faculty of Arts, University of Peradeniya, Sri Lanka, <sup>3</sup>Department of Community Medicine, Faculty of Medicine, University of Peradeniya, Sri Lanka.</i>                                                                                                                                                                                                                                                                                                                |
| 18.                                                            | OP 9  | <b>Psychosocial experiences of nurses caring for people with COVID-19 at Mahamewnawa treatment center, Kandy</b><br><u>Senavirathna SNWMWMACB<sup>1</sup></u> , Herath HMAP <sup>2</sup> , Kularathna MDLI <sup>3</sup> , Senavirathna SDIL <sup>4</sup> , Yapa HE <sup>5*</sup><br><i><sup>1</sup>Rehabilitation Hospital, Digana, Sri Lanka, <sup>2</sup>Medical Officer of Health (MOH), Nawalapitiya, <sup>3</sup>Medical Officer of Health (MOH), Kotmale, <sup>4</sup>District General Hospital, Polonnaruwa, <sup>5</sup>Department of Nursing, The Open University of Sri Lanka.</i>                                                                                                                                                                                                                                                                                                                                            |
| 19.                                                            | OP 10 | <b>Health promoting lifestyle among patients with non-communicable diseases (NCDs) attending Colombo South Teaching Hospital in Sri Lanka during the COVID-19 pandemic</b><br>Sandamali DHD <sup>1</sup> , Rajapaksha HHN <sup>1</sup> , Madhushankha MMMM <sup>1</sup> , Surangi MAS <sup>1</sup> , Subodhani ATHM <sup>1</sup> , <u>Ranasinghe RKKD<sup>2*</sup></u> , Samaranada HMVA <sup>2</sup> , Senarath NSASN <sup>1</sup> , Nisansala MSDN <sup>1</sup>                                                                                                                                                                                                                                                                                                                                                                                                                                                                       |

|                                                                          |              |                                                                                                                                                                                                                                                                                                                                                                                                                                                                                                                                                                                                                                                                                                |
|--------------------------------------------------------------------------|--------------|------------------------------------------------------------------------------------------------------------------------------------------------------------------------------------------------------------------------------------------------------------------------------------------------------------------------------------------------------------------------------------------------------------------------------------------------------------------------------------------------------------------------------------------------------------------------------------------------------------------------------------------------------------------------------------------------|
|                                                                          |              | <sup>1</sup> Department of Nursing, Faculty of Health Sciences, KAATSU International University (KIU), Sri Lanka, <sup>2</sup> Department of Medical Science in Acupuncture, Faculty of Health Sciences, KAATSU International University (KIU), Sri Lanka.                                                                                                                                                                                                                                                                                                                                                                                                                                     |
| <b>Session V - Discovery, Development &amp; Quality use of Medicines</b> |              |                                                                                                                                                                                                                                                                                                                                                                                                                                                                                                                                                                                                                                                                                                |
| 20.                                                                      | <b>OP 17</b> | <b>Perceptions of pharmacists on delivering their services to patients with non-communicable diseases during the COVID-19 pandemic; a hospital-based qualitative study in Colombo district, Sri Lanka</b><br><u>Buddhika WSU</u> <sup>1*</sup> , Senadheera GPSG <sup>1</sup> , Jayathilake MRS <sup>2</sup> , Samaranyake NR <sup>1</sup><br><sup>1</sup> Department of Pharmacy and Pharmaceutical Sciences, Faculty of Allied Health Sciences, University of Sri Jayewardenepura, Sri Lanka, <sup>2</sup> Department of Nursing and Midwifery, Faculty of Allied Health Sciences, University of Sri Jayewardenepura, Sri Lanka.                                                             |
| 21.                                                                      | <b>OP 18</b> | <b>Drug-related problems and use of STOPP/START criteria in prescriptions of geriatric patients attending cardiology clinic and diabetic centre in Teaching Hospital Jaffna</b><br>Hasna MH <sup>1</sup> , Zumra MSF <sup>1</sup> , <u>Madhusinghe HPPS</u> <sup>1</sup> , Thuvaragan S <sup>1*</sup> , Sanchayan K <sup>2</sup> , Samaranyake NR <sup>3</sup><br><sup>1</sup> Department of Pharmacy, Faculty of Allied Health Sciences, University of Jaffna., <sup>2</sup> Department of Pharmacology, Faculty of Medicine, University of Jaffna.<br><sup>3</sup> Department of Pharmacy and Pharmaceutical Sciences, Faculty of Allied Health Sciences, University of Sri Jayewardenepura. |
| 22.                                                                      | <b>OP 19</b> | <b>Comparative physicochemical profiles of BW 312 (red rice) and BW BLB 72-1 (white rice) Sri Lankan rice starches and maize starch BP as pharmaceutical excipients</b><br><u>Kankanamge SU</u> <sup>1*</sup> , Jayasuriya WJABN <sup>2</sup> , Herath HMDR <sup>2</sup> , Pathirana RN <sup>1</sup><br><sup>1</sup> Department of Pharmacy, Faculty of Allied Health Sciences, General Sir John Kotelawala Defence University, Sri Lanka, <sup>2</sup> Department of Pharmacy and Pharmaceutical Sciences, Faculty of Allied Health Sciences, University of Sri Jayewardenepura, Sri Lanka.                                                                                                   |
| 23.                                                                      | <b>OP 20</b> | <b>Studying the influence of simulated physiological conditions and physicochemical properties of amoxicillin to improve product dissolution at pH 6.8</b><br><u>Fernando WTS</u> <sup>1</sup> , Thambavita TMDD <sup>2</sup> , Mannapperuma U <sup>2</sup> , Galappatthy P <sup>2</sup><br><sup>1</sup> Department of Chemistry, Faculty of Science, University of Colombo, Sri Lanka, <sup>2</sup> Department of Pharmacology, Faculty of Medicine, University of Colombo, Sri Lanka.                                                                                                                                                                                                        |
| 24.                                                                      | <b>OP 21</b> | <b>Silver nanoparticle embedded gelatin/alginate/chitosan/polyvinylpyrrolidone Electrospun scaffold for wound dressing application</b><br><u>De Silva JHSM</u> , De Silva KMN, De Silva WRM <sup>*</sup> , Godakanda VU<br>Centre for Advanced Materials and Devices (CAMD), Department of Chemistry, Faculty of Science, University of Colombo, Sri Lanka.                                                                                                                                                                                                                                                                                                                                    |
| 25.                                                                      | <b>OP 22</b> | <b>Poly(vinylpyrrolidone)/ ethyl cellulose based electrospun wound dressing material with <i>in vitro</i> hemostatic, anti-inflammatory and antibacterial activity</b><br><u>Godakanda VU</u> <sup>1</sup> , de Silva WRM <sup>1*</sup> , Williams GR <sup>2</sup> , de Silva KMN <sup>1</sup><br><sup>1</sup> Centre for Advanced Materials and Devices (CAMD), Department of Chemistry, University of Colombo, Sri Lanka, <sup>2</sup> UCL School of Pharmacy, University College London, 29-39 Brunswick Square, London WC1N 1AX, UK.                                                                                                                                                       |

## Poster Presentations

### International Research Conference in Health Sciences 2023 (IRCHS 2023)

| Serial Number                                                 | PP ID | Title                                                                                                                                                                                                                                                                                                                                                                                                                                                                                                                                                                                                                                                                                                    |
|---------------------------------------------------------------|-------|----------------------------------------------------------------------------------------------------------------------------------------------------------------------------------------------------------------------------------------------------------------------------------------------------------------------------------------------------------------------------------------------------------------------------------------------------------------------------------------------------------------------------------------------------------------------------------------------------------------------------------------------------------------------------------------------------------|
| <b>Session I - Nursing, Management &amp; Health Promotion</b> |       |                                                                                                                                                                                                                                                                                                                                                                                                                                                                                                                                                                                                                                                                                                          |
| 1.                                                            | PP 1  | <b>Perception on body-image among undergraduates in selected faculties of astate university in Sri Lanka</b><br><u>Akurugodagama MS<sup>1*</sup></u> , Munasinghe HC <sup>1</sup> , Silvapulle WS <sup>1</sup> , Hansika HMS <sup>1</sup> , Siddeek NF <sup>1</sup> , Shiyam A <sup>2</sup> ,Amarasinghe Waas MDI <sup>3</sup> , Seneviwickrama KLMD <sup>2</sup><br><sup>1</sup> Faculty of Medical Sciences, University of Sri Jayewardenepura, Sri Lanka, <sup>2</sup> Department of Community Medicine, Faculty of Medical Sciences, University of Sri Jayewardenepura, Sri Lanka, <sup>3</sup> Department of Psychiatry, Faculty of Medical Sciences, University of Sri Jayewardenepura, Sri Lanka. |
| 2.                                                            | PP 4  | <b>Knowledge on transmission of COVID-19 among employees in selected garment factories in Sri Lanka</b><br><u>Tennakoon TMWV<sup>1*</sup></u> , Seneviwickrama KLMD <sup>2</sup><br><sup>1</sup> Faculty of Allied Health Sciences, University of Sri Jayewardenepura, Sri Lanka, <sup>2</sup> Faculty of Medical Sciences, University of Sri Jayewardenepura, Sri Lanka.                                                                                                                                                                                                                                                                                                                                |
| 3.                                                            | PP 5  | <b>Association between reproductive factors and CVD risk in non-menopausal and postmenopausal women with Type 2 Diabetes Mellitus</b><br><u>Weerawickrama PK<sup>1*</sup></u> , Weerasinghe WMCP <sup>1</sup> , Fernando IKAS <sup>1</sup> , Bulugahapitiya U <sup>2</sup> , Garusinghe C <sup>3</sup> , Karunarathna AMDS <sup>1</sup> , Abeyrathne D <sup>3</sup><br><sup>1</sup> Faculty of Allied Health Sciences, General Sir John Kotelawala Defence University, Sri Lanka, <sup>2</sup> National Hospital of Sri Lanka, <sup>3</sup> Colombo South Teaching Hospital, Sri Lanka.                                                                                                                  |
| 4.                                                            | PP 6  | <b>Empathy level and associated factors among medical undergraduates of University of Sri Jayewardenepura</b><br>Gunathunga ND <sup>1</sup> , <u>Kuruppu KDRTM<sup>1</sup></u> , Wijesuriya MWAHS <sup>1</sup> , Nanayakkara SK <sup>1</sup> , Irosh BU <sup>1</sup> , Edirisinghe EAST <sup>3</sup> , Shiyam A <sup>2</sup> , Seneviwickrama KLMD <sup>2</sup><br><sup>1</sup> Faculty of Medical Sciences, University of Sri Jayewardenepura, Sri Lanka, <sup>2</sup> Department of Community Medicine, Faculty of Medical Sciences, University of Sri Jayewardenepura, Sri Lanka, <sup>3</sup> Department of Anatomy, Faculty of Medical Sciences, University of Sri Jayewardenepura, Sri Lanka.      |
| 5.                                                            | PP 7  | <b>Satisfaction of E-learning and associated factors among nursing undergraduates during COVID-19 pandemic in selected state universities of Western Province, Sri Lanka</b><br><u>Alahakoon ANJ<sup>*</sup></u> , Meegoda MKDL<br><sup>1</sup> Faculty of Allied Health Sciences, University of Sri Jayewardenepura, Sri Lanka.                                                                                                                                                                                                                                                                                                                                                                         |
| 6.                                                            | PP 8  | <b>Impact of emotional intelligence on caring behavior among government nursing officers in Teaching Hospital Anuradhapura</b><br><u>Dissanayake RY<sup>1</sup></u> , Herath HMASK <sup>2</sup> , Jayathissa, PPSK <sup>1</sup> Kethikenella KGSS <sup>1</sup> , Wijayasunndara WMSK <sup>3*</sup> Priyanthi WN <sup>4</sup>                                                                                                                                                                                                                                                                                                                                                                             |

|                                                                           |              |                                                                                                                                                                                                                                                                                                                                                                                                                                                                                                                                                                                                                                                                                         |
|---------------------------------------------------------------------------|--------------|-----------------------------------------------------------------------------------------------------------------------------------------------------------------------------------------------------------------------------------------------------------------------------------------------------------------------------------------------------------------------------------------------------------------------------------------------------------------------------------------------------------------------------------------------------------------------------------------------------------------------------------------------------------------------------------------|
|                                                                           |              | <sup>1</sup> Teaching Hospital, Anuradhapura, Sri Lanka, <sup>2</sup> General Hospital Ampara, Sri Lanka, <sup>3</sup> College of Nursing, Anuradhapura, Sri Lanka, <sup>4</sup> The Open University, Sri Lanka.                                                                                                                                                                                                                                                                                                                                                                                                                                                                        |
| 7.                                                                        | <b>PP 9</b>  | <b>PP 9: Level of self-directed learning and associated factors among nursing students in three selected colleges of nursing in Sri Lanka</b><br>Dissanayaka HMPN <sup>1</sup> , Ekanayaka EMCK <sup>2</sup> , Kumari WPP <sup>3</sup> , Thennakoon TMLG <sup>4</sup> , Wijayasundara WMSK <sup>5*</sup> , Samarasekara PWGDP <sup>6</sup><br><sup>1</sup> Divisional Hospital Galenbidumuwewa, Sri Lanka, <sup>2</sup> Base Hospital Kekirawa, Sri Lanka <sup>3</sup> Base Hospital Thambuththegama. Sri Lanka, <sup>4</sup> Provincial Health Training Center, Anuradhapura, <sup>5</sup> College of Nursing, Anuradhapura, Sri Lanka, <sup>6</sup> The Open University of Sri Lanka. |
| 8.                                                                        | <b>PP 10</b> | <b>The effect of sleep deprivation on short-term memory of undergraduates of KIU, Sri Lanka</b><br>Kumara KMDD <sup>1</sup> , Boralugoda SYM <sup>1</sup> , Zahir MRM <sup>1</sup> , Sara AF <sup>1</sup> , Madulakkhana DDK <sup>1</sup> , Dunukara DMJDK <sup>1*</sup> , Priyadarshani AMB <sup>2</sup><br><sup>1</sup> Department of Biomedical Sciences, Faculty of Health Sciences, KAATSU International University (KIU), Sri Lanka, <sup>2</sup> Department of Medical Laboratory Sciences, Faculty of Allied Health Sciences, University of Sri Jayewardenepura, Sri Lanka.                                                                                                     |
| 9.                                                                        | <b>PP 11</b> | <b>Knowledge, attitudes and practices on urinary tract infections among school teachers in selected schools in Kuliyaipitiya and Giriulla, Sri Lanka</b><br>Safwan SM <sup>1</sup> , Dias NTB <sup>2</sup> , Dilhari KAA <sup>2*</sup><br><sup>1</sup> Department of Nursing and Midwifery, Faculty of Allied Health Sciences, University of Sri Jayewardenepura, Sri Lanka, <sup>2</sup> Department of Basic Sciences, Faculty of Allied Health Sciences, University of Sri Jayewardenepura, Sri Lanka.                                                                                                                                                                                |
| 10.                                                                       | <b>PP 13</b> | <b>Relationship between cardiopulmonary endurance and leisure time physical activity among A/L students in selected two rural schools in Batticaloa district</b><br>Sarmi K <sup>1*</sup> , Yashoda H <sup>2</sup><br><sup>1</sup> Faculty of Medicine, Department of Allied Health Sciences, University of Colombo, Sri Lanka, <sup>2</sup> Department of Paediatrics, Faculty Medicine, University of Colombo, Sri Lanka.                                                                                                                                                                                                                                                             |
| 11.                                                                       | <b>PP 14</b> | <b>Geriatric non-pharmacological mental healthcare practices used at Kaithady state home for elders in Sri Lanka</b><br>Mayuri S <sup>1*</sup> , Rajeetha M <sup>2</sup><br><sup>1</sup> Postgraduate Institute of Science, University of Peradeniya, Sri Lanka, <sup>2</sup> Government Siddha Medical College, Palayamkottai, Tirunelveli, Tamil Nadu, India.                                                                                                                                                                                                                                                                                                                         |
| 12.                                                                       | <b>PP 24</b> | <b>PP 24: Facilitators and barriers of participation for continuing professional education among nurses in a selected hospital in Gampaha district, Sri Lanka</b><br>Ranasinghe HRAUN, Damayanthi LC<br>Faculty of Allied Health Sciences, University of Sri Jayewardenepura, Sri Lanka.                                                                                                                                                                                                                                                                                                                                                                                                |
| <b>Session II - Discovery, Development &amp; Quality use of Medicines</b> |              |                                                                                                                                                                                                                                                                                                                                                                                                                                                                                                                                                                                                                                                                                         |
| 13.                                                                       | <b>PP 29</b> | <b>Invitro quality and stability assessment of furosemide 40 mg tablets available in Karapitiya, Galle, Sri Lanka</b><br>Anuruddhika KPII <sup>*</sup> , Jayasinghe M, Subasinghe HWAS, Wijesekara K<br>Department of Pharmacy, Faculty of Allied Health Sciences, University of Ruhuna, Sri Lanka.                                                                                                                                                                                                                                                                                                                                                                                     |
| 14.                                                                       | <b>PP 30</b> | <b>Repackaging propranolol tablets in plastic bags: Stability under different storage conditions</b><br>Madhushika IWH <sup>*</sup> , Jayasinghe M, Wijesekara KAKD, Subasinghe HWAS<br>Department of Pharmacy, Faculty of Allied Health Sciences, University of Ruhuna, Sri Lanka.                                                                                                                                                                                                                                                                                                                                                                                                     |

|     |       |                                                                                                                                                                                                                                                                                                                                                                                                                                                                                                                                                |
|-----|-------|------------------------------------------------------------------------------------------------------------------------------------------------------------------------------------------------------------------------------------------------------------------------------------------------------------------------------------------------------------------------------------------------------------------------------------------------------------------------------------------------------------------------------------------------|
| 15. | PP 31 | <p><b>Perception towards storage, disposal and misuse of unused and expired pharmaceuticals in households amongst the staff working at Dhakshinapaya ministry complex, Labuduwa, Galle</b><br/> <u>Chandrasena NKPG</u><sup>1</sup>, Karunanayaka KDSV<sup>1*</sup>, Gunawardena S<sup>2</sup><br/> <sup>1</sup>Department of Pharmacy, Faculty of Allied Health Sciences, University of Ruhuna, Sri Lanka, <sup>2</sup>Department of Physiology, Faculty of Medicine, University of Ruhuna, Sri Lanka.</p>                                    |
| 16. | PP 32 | <p><b>Analysis of <i>invitro</i> antioxidant properties of Green synthesized Ni/reduced graphene oxide composite</b><br/> <u>Gamage HMGMP</u><sup>1</sup>, Madushani WSAT<sup>1</sup>, Pahalagedara MN<sup>2*</sup><br/> <sup>1</sup>Department of Medical Laboratory Sciences, Faculty of Allied Health Sciences, University of Sri Jayewardenepura, Sri Lanka, <sup>2</sup>Department of Basic Sciences, Faculty of Allied Health Sciences, University of Sri Jayewardenepura, Sri Lanka.</p>                                                |
| 17. | PP 33 | <p><b>Determination of the knowledge on rational usage of oral anticoagulant among patients attending to Cardiology Clinic at Teaching Hospital Jaffna</b><br/> <u>Ijasa Ibrahim</u><sup>1*</sup>, Paramanathan Kalki<sup>1</sup>, Rajendran Surenthirakumaran<sup>2</sup>, Mahesan Guruparan<sup>3</sup><br/> <sup>1</sup>Department of Pharmacy, Faculty of Allied Health Sciences, University Of Jaffna, Sri Lanka, <sup>2</sup>Faculty of Medicine, University Of Jaffna, Sri Lanka, <sup>3</sup>Teaching Hospital, Jaffna, Sri Lanka.</p> |
| 18. | PP 34 | <p><b>Non-steroidal anti-inflammatory drug use in elderly patients; A hospital based cross-sectional study</b><br/> <u>Malika WI</u><sup>*</sup>, De Silva KIM, Subasinghe HWAS<br/> Department of Pharmacy, Faculty of Allied Health Sciences, University of Ruhuna</p>                                                                                                                                                                                                                                                                       |
| 19. | PP 35 | <p><b>Irregular medication use among geriatric patients with chronic diseases: A hospital based cross sectional study</b><br/> <u>Tharangani AR</u><sup>*</sup>, De Silva KIM, Subasinghe HWAS<br/> Department of Pharmacy, Faculty of Allied Health Sciences, University of Ruhuna, Sri Lanka.</p>                                                                                                                                                                                                                                            |
| 20. | PP 36 | <p><b>Relationship between PT/INR and APTT in patients on warfarin: A study at a tertiary care teaching hospital</b><br/> <u>Attanayake MASM</u><sup>1</sup>, Manathunga ID<sup>1*</sup>, Kulathilake HWCK<sup>2</sup><br/> <sup>1</sup>Department of Medical Laboratory Sciences, Faculty of Medical Sciences, University of Sri Jayewardenepura, Sri Lanka, <sup>2</sup>Department of Pathology, Faculty of Medical Sciences, University of Sri Jayewardenepura, Sri Lanka.</p>                                                              |
| 21. | PP 37 | <p><b>Formulation and <i>invitro</i> evaluation of an antibacterial cream with <i>Nyctanthes arbor-tristis</i> L. flower extract</b><br/> <u>Silva MAH</u><sup>1</sup>, Siriwardhene MA<sup>2</sup>, Karunanayaka KDSV<sup>1</sup>, Yasarathna KWGKP<sup>1*</sup><br/> <sup>1</sup>Department of Pharmacy, Faculty of Allied Health Sciences, University of Ruhuna, Sri Lanka, <sup>2</sup> Department of Pharmacy and Pharmaceutical Sciences, Faculty of Allied Health Sciences, University of Sri Jayewardenepura, Sri Lanka.</p>           |
| 22. | PP 38 | <p><b>Designing and validation of patient information leaflet for pediatric amoxicillin powder for oral suspension for oral suspension</b><br/> <u>Sandesh JT</u><sup>*</sup>, Dissanayake GDC, Prasadi GAM<br/> Department of Pharmacy, Faculty of Allied Health Sciences, University of Ruhuna, Sri Lanka.</p>                                                                                                                                                                                                                               |

|                                                                     |              |                                                                                                                                                                                                                                                                                                                                                                                                                                                                                                                                   |
|---------------------------------------------------------------------|--------------|-----------------------------------------------------------------------------------------------------------------------------------------------------------------------------------------------------------------------------------------------------------------------------------------------------------------------------------------------------------------------------------------------------------------------------------------------------------------------------------------------------------------------------------|
| 23.                                                                 | <b>PP 39</b> | <b><i>In vitro</i> evaluation of radical scavenging activity of extracts of <i>Pterocarpus marsupium</i> (Gammalu) bark</b><br>Nawarathna TPH*, Hettihewa SK, Dissanayake AS<br><i>Department of Pharmacy, Faculty of Allied Health Sciences, University of Ruhuna, Sri Lanka.</i>                                                                                                                                                                                                                                                |
| 24.                                                                 | <b>PP 40</b> | <b>Customer satisfaction towards pharmaceutical care provided by the community pharmacies in selected MOH areas, Galle District, Sri Lanka</b><br>Dissanayake GDC*, Sandesh JT, Prasadi GAM<br><i>Department of Pharmacy, Faculty of Allied Health Sciences, University of Ruhuna, Sri Lanka.</i>                                                                                                                                                                                                                                 |
| 25.                                                                 | <b>PP 41</b> | <b>Assessment of prices, packaging, and quality of paracetamol tablets dispensed by public and private sector pharmacies in Karapitiya</b><br>Pramodika MAG*, Jayasinghe M, Subasinghe HWAS, Wijesekara K<br><i>Department of Pharmacy, Faculty of Allied Health Sciences, University of Ruhuna, Sri Lanka.</i>                                                                                                                                                                                                                   |
| 26.                                                                 | <b>PP 42</b> | <b><i>In vitro</i> antioxidant activity of leaves &amp; unripen fruits of “Tanin and Vega F1” hybrid papaya on the basis of DPPH free radical scavenging</b><br>Needhiraja NP <sup>1</sup> , Krishnamoorthy T <sup>1</sup> , Jayasooriya ATR <sup>1</sup> , Srikokulan S <sup>1*</sup> , Senthilnathanan M <sup>2</sup><br><sup>1</sup> <i>Department of Pharmacy, Faculty of Allied Health Sciences, University of Jaffna,</i> <sup>2</sup> <i>Department of Chemistry, Faculty of Science, University of Jaffna, Sri Lanka.</i> |
| 27.                                                                 | <b>PP 43</b> | <b><i>In vitro</i> determination of alpha amylase inhibitory activity of two selected medicinal plants extracts</b><br>Liyanaarachchi LVV <sup>1</sup> , Rathnayake HMAL <sup>1</sup> , Wijesundara WMAGUI <sup>1</sup> , Sivasinthujah S <sup>1*</sup> , Manoranjan T <sup>2</sup><br><sup>1</sup> <i>Department of Pharmacy, Faculty of Allied Health Sciences, University of Jaffna, Sri Lanka,</i> <sup>2</sup> <i>Department of Chemistry, Faculty of Science, University of Jaffna, Sri Lanka.</i>                          |
| 28.                                                                 | <b>PP 44</b> | <b>Prescribing patterns of lipid lowering drugs at Teaching hospital Karapitiya</b><br>Edirisinghe EAAS <sup>1*</sup> , Pathiraja VM <sup>1</sup> , Dhanarisi J <sup>2</sup><br><sup>1</sup> <i>Department of pharmacy, Faculty of Allied Health Sciences, University of Ruhuna, Sri Lanka,</i> <sup>2</sup> <i>Local Production &amp; Assistance Unit, Regulation and Prequalification Department, Access to Medicines and Health Products Division, World Health Organization, Geneva, Switzerland</i>                          |
| 29.                                                                 | <b>PP 45</b> | <b>Post-marketing quality assessment of metformin hydrochloride tablets available in Karapitiya</b><br>Priyanath HYS*, Jayasinghe M, Subasinghe HWAS, Wijesekara K<br><i>Department of pharmacy, Faculty of Allied Health Sciences, University of Ruhuna, Sri Lanka.</i>                                                                                                                                                                                                                                                          |
| <b>Session III - Health, Nutrition &amp; Laboratory Diagnostics</b> |              |                                                                                                                                                                                                                                                                                                                                                                                                                                                                                                                                   |
| 30.                                                                 | <b>PP 63</b> | <b>PP 63: Formulation of nutrient supplement from selected local grain varieties and comparison of their nutritional properties</b><br>Perera TPSS, Navaratna SB, Prashantha MAB, Godakumbura PI*<br><i>Department of Chemistry, Faculty of Applied sciences, University of Sri Jayewardenepura, Sri Lanka.</i>                                                                                                                                                                                                                   |
| 31.                                                                 | <b>PP 64</b> | <b>Knowledge and practice regarding prevention and management of anemia and influence of socio-demographics factors among antenatal mothers in Nallur MOH division.</b><br>Ahamed MIA <sup>1*</sup> , Surenthirakumaran R <sup>2</sup> , Thabotharan D <sup>1</sup> , Nivetha K <sup>1</sup>                                                                                                                                                                                                                                      |

|     |              |                                                                                                                                                                                                                                                                                                                                                                                                                                                                                                                                                                                                                                                                                                                                                                                                                 |
|-----|--------------|-----------------------------------------------------------------------------------------------------------------------------------------------------------------------------------------------------------------------------------------------------------------------------------------------------------------------------------------------------------------------------------------------------------------------------------------------------------------------------------------------------------------------------------------------------------------------------------------------------------------------------------------------------------------------------------------------------------------------------------------------------------------------------------------------------------------|
|     |              | <sup>1</sup> Department of Nursing, Faculty of Allied Health Sciences, University of Jaffna, Sri Lanka, <sup>2</sup> Department of Community and Family Medicine, Faculty of Medicine, University of Jaffna, Sri Lanka.                                                                                                                                                                                                                                                                                                                                                                                                                                                                                                                                                                                         |
| 32. | <b>PP 65</b> | <b>Establishment and maintenance of <i>Aedes aegypti</i> (Linnaeus) mosquito colonies for vector control studies of dengue</b><br>Dilani PVD <sup>1</sup> , Wickramasinghe PDSU <sup>1</sup> , Hapugoda M <sup>2</sup> , Silva GN <sup>1</sup> , Hettiarachchi C <sup>1</sup> , Dassanayake RS <sup>1</sup> , Gunawardene YINS <sup>2*</sup><br><sup>1</sup> Department of Chemistry, Faculty of Science, University of Colombo, Colombo, Sri Lanka, <sup>2</sup> Molecular Medicine Unit, Faculty of Medicine, University of Kelaniya, Ragama, Sri Lanka.                                                                                                                                                                                                                                                      |
| 33. | <b>PP 66</b> | <b>Knowledge and its associated factors on deficiency anaemia among pregnant mothers attending antenatal clinics in selected medical officer of health areas in Colombo district</b><br>Jayamuni NA <sup>1*</sup> , Ranasinghe RARC <sup>1</sup> , Alahapperuma SN <sup>1</sup> , Imasha KAC <sup>1</sup> , Athukorala ACR <sup>1</sup> , Kulathilake HWCK <sup>3</sup> , Alagiyawanna AMADK <sup>2</sup> , Jayasinghe LV <sup>2</sup> , Seneviwickrama KLMD <sup>2</sup><br><sup>1</sup> Faculty of Medical Sciences, University of Sri Jayewardenepura, Sri Lanka, <sup>2</sup> Department of Community Medicine, Faculty of Medical Sciences, University of Sri Jayewardenepura, Sri Lanka, <sup>3</sup> Department of Pathology, Faculty of Medical Sciences, University of Sri Jayewardenepura, Sri Lanka. |
| 34. | <b>PP 67</b> | <b>Application of reverse transcriptase-polymerase chain reaction assay in detection of BCR-ABL1 fusion gene in suspected patients with Chronic Myelogenous Leukemia (CML)</b><br>Herath HMNN, Basnayake BMHP, Wijeyanayake LDSR, Kugadasan M, Indrajith C, Denipitiya DTH <sup>*</sup><br>Molecular Diagnostics Department, Lanka Hospitals Diagnostics (pvt) Ltd, Colombo 05, Sri Lanka.                                                                                                                                                                                                                                                                                                                                                                                                                      |
| 35. | <b>PP 68</b> | <b>Practice of biosafety guidelines issued during the COVID-19 pandemic in histopathology laboratories of two tertiary care centres in Colombo district</b><br>Shafra MRF <sup>1</sup> , Jayathilaka SBSP <sup>1*</sup> , Prematilleke IV <sup>2</sup><br><sup>1</sup> Department of Medical Laboratory Sciences, Faculty of Allied Health Sciences, University of Sri Jayewardenepura, Sri Lanka, <sup>2</sup> Department of Pathology, Faculty of Medical Sciences, University of Sri Jayewardenepura, Sri Lanka.                                                                                                                                                                                                                                                                                             |
| 36. | <b>PP 69</b> | <b>The comparison of atherogenic index of plasma (AIP), visceral adiposity index (VAI), lipid accumulation product (LAP) between normal subjects and patients with acute myocardial infarction admitted to a tertiary care hospital, Sri Lanka</b><br>Jayawardhana PSG <sup>1</sup> , Thathsarani SMTO <sup>1</sup> , Wijesekara GUS <sup>1*</sup> , Bandara EMS <sup>1</sup> , Thushara Matthias <sup>2</sup><br><sup>1</sup> Department of Medical Laboratory Sciences, Faculty of Allied Health Sciences, University of Sri Jayewardenepura, Sri Lanka, <sup>2</sup> Department of Medicine, Faculty of Medical Sciences, University of Sri Jayewardenepura, Sri Lanka.                                                                                                                                      |
| 37. | <b>PP 70</b> | <b>Biofilm formation and multidrug resistance of coliforms isolated from malignant patients with urinary tract infections</b><br>Vitharana BM <sup>1</sup> , Wahalathantry DM <sup>1*</sup> , Gunasekara TDCP <sup>2</sup> , Chathuranaga BAG <sup>1</sup> , Gunasekara SP <sup>3</sup><br><sup>1</sup> Department of Medical Laboratory Sciences, Faculty of Allied Health Sciences, University of Sri Jayewardenepura, Sri Lanka, <sup>2</sup> Department of Microbiology, Faculty of Medical Sciences, University of Sri Jayewardenepura, Sri Lanka, <sup>3</sup> Apeksha Hospital, Maharagama, Sri Lanka.                                                                                                                                                                                                   |
| 38. | <b>PP 71</b> | <b>Total phenolic and total flavonoid contents in crude boiled broth of commercially available Sri Lankan rice (<i>Oryzasativa L.</i>) varieties</b><br>Gunawardana JW <sup>1,3</sup> , Gunawardena SA <sup>2</sup> , Perera IC <sup>3</sup> , Wageesha NDA <sup>4</sup> , Witharana C <sup>1*</sup>                                                                                                                                                                                                                                                                                                                                                                                                                                                                                                            |

|                                                                |              |                                                                                                                                                                                                                                                                                                                                                                                                                                                                                                                                                                                                                                                                                             |
|----------------------------------------------------------------|--------------|---------------------------------------------------------------------------------------------------------------------------------------------------------------------------------------------------------------------------------------------------------------------------------------------------------------------------------------------------------------------------------------------------------------------------------------------------------------------------------------------------------------------------------------------------------------------------------------------------------------------------------------------------------------------------------------------|
|                                                                |              | <sup>1</sup> Department of Biochemistry & Molecular Biology, Faculty of Medicine, University of Colombo, Sri Lanka, <sup>2</sup> Department of Forensic Medicine & Toxicology, Faculty of Medicine, University of Colombo, Sri Lanka, <sup>3</sup> Department of Zoology & Environment Sciences, Faculty of Science, University of Colombo, Sri Lanka, <sup>4</sup> Department of Biochemistry, Faculty of Medicine, Sabaragamuwa University of Sri Lanka.                                                                                                                                                                                                                                  |
| 39.                                                            | <b>PP 72</b> | <b>Preliminary study on fluoride exposure and associated renal health outcomes of rural children from CKDu endemic and non-endemic regions</b><br><u>Wijesundara WMPA*</u> , De Silva HSRD, Bandara HMNN, Hasinthara GAS, Sandamini PMMA, Gunasekara TDKSC, De Silva PMCS<br><i>Department of Zoology, University of Ruhuna, Sri Lanka.</i>                                                                                                                                                                                                                                                                                                                                                 |
| 40.                                                            | <b>PP 73</b> | <b>A laboratory-based study for determination of cytomegalovirus infection</b><br><u>Wijeyanayake LDSR</u> , Basnayake BMHP, Herath HMNN, Kugadasan M, Indrajith C, Denipitiya DTH*<br><i>Molecular Diagnostics Department, Lanka Hospitals Diagnostics (PVT) Ltd, Colombo 05, Sri Lanka.</i>                                                                                                                                                                                                                                                                                                                                                                                               |
| <b>Session IV - Nursing, Management &amp; Health Promotion</b> |              |                                                                                                                                                                                                                                                                                                                                                                                                                                                                                                                                                                                                                                                                                             |
| 41.                                                            | <b>PP 02</b> | <b>Quality of life of school teachers during COVID-19 pandemic in Biyagama educational division, Gampaha District, Sri Lanka</b><br><u>Sewwandi WKJ*</u> , Ilankoon IMPS<br><i>Department of Nursing and Midwifery, Faculty of Allied Health Sciences, University of Sri Jayewardenepura, Sri Lanka.</i>                                                                                                                                                                                                                                                                                                                                                                                    |
| 42.                                                            | <b>PP 15</b> | <b>Assessing the perceived vulnerability of nursing officers towards tuberculosis at the National Hospital for Respiratory Diseases in Welisara, Sri Lanka</b><br>Priyadarshani NAW <sup>1,2</sup> , Assella IL <sup>1,3</sup> , Rukmani MWADT <sup>1,2</sup> , Fernando MRC <sup>1,2</sup> , Priyashanthi JM <sup>1,4</sup> Sandakumari HHHS <sup>1</sup> , Kanchana KTG <sup>1</sup><br><i><sup>1</sup>Department of Nursing, KAATSU International University (KIU), Sri Lanka, <sup>2</sup>District General Hospital Gampaha, Sri Lanka, <sup>3</sup>National Hospital for Respiratory Diseases Welisara, Sri Lanka, <sup>4</sup>North Colombo Teaching Hospital, Ragama, Sri Lanka.</i> |
| 43.                                                            | <b>PP 16</b> | <b>Nursing informatics and learning health system among nurses during COVID-19 at selected higher education institute in Sri Lanka</b><br>Harshani PK <sup>1,2</sup> , Damayanthi WRS <sup>1,3</sup> , Rathnayaka GHAN <sup>1,2</sup> , Sandakumari HHS <sup>1</sup> , Kanchana KTG <sup>1</sup><br><i><sup>1</sup>KAATSU International University (KIU), Sri Lanka, <sup>2</sup>National Hospital of Sri Lanka, Colombo, Sri Lanka, <sup>3</sup>Colombo South Teaching Hospital, Sri Lanka</i>                                                                                                                                                                                             |
| 44.                                                            | <b>PP 17</b> | <b>Demographic and clinical characteristics among type 2 diabetic patients, attending the Diabetic Centre, Teaching Hospital Jaffna</b><br><u>Thivya K*</u> , <u>Risla MRF<sup>1</sup></u> , Samiya HM <sup>1</sup> , Arasaratnam V <sup>2</sup> , Aravinthan M <sup>3</sup><br><i><sup>1</sup>Department of Medical Laboratory Sciences, Faculty of Allied Health Sciences, University of Jaffna, Sri Lanka, <sup>2</sup>Department of Biochemistry, Faculty of Medicine, University of Jaffna, Sri Lanka, <sup>3</sup>Diabetic Centre, Teaching Hospital, Jaffna, Sri Lanka.</i>                                                                                                          |
| 45.                                                            | <b>PP 19</b> | <b>Knowledge of iron deficiency anemia management among pregnant women in Narahenpita Area, Sri Lanka</b><br><u>Kumaran M*</u> , Rajapakshe NY, Saeed S, Khaleel ZA<br><i>School of Nursing, International Institute of Health Sciences, Welisara, Sri Lanka.</i>                                                                                                                                                                                                                                                                                                                                                                                                                           |

|     |              |                                                                                                                                                                                                                                                                                                                                                                                                                                                                                                                                                                                                                                                                                                                           |
|-----|--------------|---------------------------------------------------------------------------------------------------------------------------------------------------------------------------------------------------------------------------------------------------------------------------------------------------------------------------------------------------------------------------------------------------------------------------------------------------------------------------------------------------------------------------------------------------------------------------------------------------------------------------------------------------------------------------------------------------------------------------|
| 46. | <b>PP 20</b> | <p><b>Anemia and its etiological factors among elderly individuals attending the Family Practice Centre at the Faculty of Medical Sciences, University of Sri Jayewardenepura</b><br/> Karunasena DKG<sup>1*</sup>, <u>Sewwandi KKD</u><sup>1</sup>, Fernandopulle B<sup>2</sup>, De Silva H<sup>3</sup>, Darshana LGT<sup>1</sup><br/> <sup>1</sup>Department of Medical Laboratory Sciences, Faculty of Allied Health Sciences, University of Sri Jayewardenepura, Sri Lanka, <sup>2</sup>Department of Pathology, Faculty of Medical Sciences, University of Sri Jayewardenepura, Sri Lanka, <sup>3</sup>Department of Family Medicine, Faculty of Medical Sciences, University of Sri Jayewardenepura, Sri Lanka.</p> |
| 47. | <b>PP 21</b> | <p><b>Knowledge and attitudes towards sexually transmitted diseases among undergraduates of KAATSU International University (KIU), Sri Lanka</b><br/> <u>Alwis WLM</u><sup>1</sup>, Minnath MFS<sup>1</sup>, Gunarathne MGPA<sup>1</sup>, Tharindu VDR<sup>1</sup>, Fernando RMS<sup>1</sup>, Fasmila MFF<sup>1</sup>, Kulathunga KMHH<sup>1*</sup>, Sampath MKA<sup>2</sup><br/> <sup>1</sup>Department of Biomedical Science, Faculty of Health Sciences, KAATSU International University, Sri Lanka, <sup>2</sup>Sri Lanka Institute of Biotechnology- Colombo, Sri Lanka.</p>                                                                                                                                         |
| 48. | <b>PP 22</b> | <p><b>Self-care measures on managing Coronary-Artery-Disease (CAD) and its associated sociodemographic factors among patients with CAD attending the Cardiology Unit, National Hospital Sri Lanka</b><br/> Silva NGGH, Perera RASG, Nadeeka PW, Sadamali WAK, Nisansala MWN, <u>Senarath NSASN</u><sup>*</sup><br/> Department of Basic Science, Faculty of Nursing, KAATSU International University (KIU), Sri Lanka.</p>                                                                                                                                                                                                                                                                                                |
| 49. | <b>PP 23</b> | <p><b>Preference, knowledge, and attitudes towards the companionship during labour; A cross-sectional study among antenatal clinic attendees in Kandy district</b><br/> <u>Perera KCN</u><sup>*</sup>, Weerasingha BRGTK<br/> Department of Nursing, Faculty of Allied Health Sciences, University of Peradeniya, Sri Lanka.</p>                                                                                                                                                                                                                                                                                                                                                                                          |
| 50. | <b>PP 25</b> | <p><b>Factors associated with mental health among antenatal mothers attending Castle Street Hospital for Women during the COVID– 19 Pandemic</b><br/> Tennakoon NMDN, Ruwanthi MDA, Hunukumbura WMIM, Ariyawansa BI, Karunarathne NMRA, <u>Ranaweera RAND</u><sup>*</sup>, Nisansala MWN, Senarath NSASN<br/> Department of Nursing, Faculty of Nursing, KAATSU International University, Sri Lanka.</p>                                                                                                                                                                                                                                                                                                                  |
| 51. | <b>PP 26</b> | <p><b>Knowledge and attitudes towards usage of face masks during COVID-19 pandemic among nursing students, Faculty of Allied Health Sciences, University of Peradeniya: A descriptive cross-sectional study</b><br/> <u>Nishshanka NMDC</u><sup>1*</sup>, Kumarasiri PVR<sup>2</sup>, Weerasingha BRGTK<sup>1</sup><br/> <sup>1</sup>Department of Nursing, Faculty of Allied Health Sciences, University of Peradeniya, <sup>2</sup>Department of Community Medicine, Faculty of Medicine, University of Peradeniya.</p>                                                                                                                                                                                                 |
| 52. | <b>PP 27</b> | <p><b>Knowledge, practices and perceived barriers regarding patient education on inhaler use among nurses working in a tertiary care hospital, Western province, Sri Lanka</b><br/> <u>Liyanaarachchi PLDS</u><sup>1*</sup>, Abeyratne RMTB<sup>2</sup><br/> <sup>1</sup>National Hospital of Sri Lanka, Sri Lanka, <sup>2</sup> Department of Nursing and Midwifery, Faculty of Allied Health Sciences, University of Sri Jayewardenepura, Sri Lanka.</p>                                                                                                                                                                                                                                                                |

|                                                                          |       |                                                                                                                                                                                                                                                                                                                                                                                                                                                                                                                                                                                                                                                                                                                                                                                                                   |
|--------------------------------------------------------------------------|-------|-------------------------------------------------------------------------------------------------------------------------------------------------------------------------------------------------------------------------------------------------------------------------------------------------------------------------------------------------------------------------------------------------------------------------------------------------------------------------------------------------------------------------------------------------------------------------------------------------------------------------------------------------------------------------------------------------------------------------------------------------------------------------------------------------------------------|
| 53.                                                                      | PP 28 | <p><b>Factors associated with self-care agency in patients with coronary heart disease following percutaneous coronary intervention at Teaching Hospital, Kalutara</b></p> <p>Senevirathne PM<sup>1</sup>, Bennet UGNL<sup>1</sup>, <u>Amarasinghe PDHR</u><sup>1</sup>, Sandamali MN<sup>1</sup>, Yapa HE<sup>2*</sup></p> <p><sup>1</sup>Teaching Hospital, Kalutara, Sri Lanka, <sup>2</sup>Department of Nursing, The Open University of Sri Lanka.</p>                                                                                                                                                                                                                                                                                                                                                       |
| <b>Session V - Discovery, Development &amp; Quality use of Medicines</b> |       |                                                                                                                                                                                                                                                                                                                                                                                                                                                                                                                                                                                                                                                                                                                                                                                                                   |
| 54.                                                                      | PP 46 | <p><b>Association of patient specific factors on the total weekly dose of warfarin</b></p> <p><u>Liyanage HS</u><sup>1*</sup>, De Silva KIM<sup>1</sup>, Prabodha LBL<sup>2</sup></p> <p><sup>1</sup>Department of Pharmacy, Faculty of Allied Health Sciences, University of Ruhuna, Sri Lanka, <sup>2</sup>Department of Anatomy, Faculty of Medicine, University of Ruhuna, Sri Lanka.</p>                                                                                                                                                                                                                                                                                                                                                                                                                     |
| 55.                                                                      | PP 47 | <p><b>Nanoemulsions encapsulated with aqueous leaf extract of <i>Coccinia grandis</i> L. Voigt (Kovakka) as a potential nanonutraceutical agent against type 2 diabetes mellitus</b></p> <p><u>Wickramasinghe ASD</u><sup>*1</sup>, Attanayake AP<sup>2</sup>, Kalansuriya P<sup>2</sup></p> <p><sup>1</sup>Department of Pharmacy, Faculty of Health Sciences, The Open University of Sri Lanka, Department of Biochemistry, Faculty of Medicine, University of Ruhuna, Sri Lanka.</p>                                                                                                                                                                                                                                                                                                                           |
| 56.                                                                      | PP 49 | <p><b><i>In-vitro</i> antimicrobial efficacy of an herbal eye wash against pathogens causing conjunctivitis</b></p> <p><u>Ambujan B</u><sup>1</sup>, Damayanthi HLI<sup>1*</sup>, Uluwaduge DI<sup>2</sup>, Peiris KPP<sup>3</sup>, Bandara EMS<sup>1</sup></p> <p><sup>1</sup>Department of Medical Laboratory Sciences, Faculty of Allied Health Sciences, University of Sri Jayawardenepura, Sri Lanka, <sup>2</sup>Department of Basic Sciences, Faculty of Allied Health Sciences, University of Sri Jayawardenepura, Sri Lanka, <sup>3</sup>Department of Biochemistry and Clinical Chemistry, Faculty of Medicine, University of Moratuwa, Sri Lanka, <sup>4</sup>Department of Shalya Shalakya, Faculty of Indigenous Medicine, Gampaha Wickramarachchi University of Indigenous Medicine, Sri Lanka.</p> |
| 57.                                                                      | PP 50 | <p><b>Price, availability and supplier comparison of price-controlled medicines in Sri Lanka</b></p> <p><u>Shashiprabha NAB</u><sup>1*</sup>, Jayasinghe M<sup>1</sup>, Dorabawila SSKBM<sup>2</sup></p> <p><sup>1</sup>Department of Pharmacy, Faculty of Allied Health Sciences, University of Ruhuna, Sri Lanka, <sup>2</sup>Department of Economics and Statistics, Faculty of Arts, University of Peradeniya, Sri Lanka.</p>                                                                                                                                                                                                                                                                                                                                                                                 |
| 58.                                                                      | PP 51 | <p><b>Antibiotic resistance patterns of <i>Escherichia coli</i> in paediatric urinary tract infections</b></p> <p>Wickramarathne DKN<sup>1,2</sup>, Herath HMCK<sup>1,3</sup>, <u>Chathurika PTC</u><sup>4</sup>, Nissanka NMC<sup>4</sup>, Dassanayake M<sup>2</sup>, Wimalagunawardana P<sup>3</sup>, Dilhari KAA<sup>4*</sup></p> <p><sup>1</sup>Department of Medical Laboratory Sciences, The Open University of Sri Lanka, Sri Lanka, <sup>2</sup>Lady Ridgeway Hospital, Sri Lanka, <sup>3</sup>District General Hospital, Polonnaruwa, Sri Lanka, <sup>4</sup>Department of Basic Sciences, Faculty of Allied Health Sciences, University of Sri Jayawardenepura, Sri Lanka.</p>                                                                                                                          |
| 59.                                                                      | PP 54 | <p><b><i>In vitro</i> carbohydrate metabolizing enzyme inhibitory potential of alginate nanoparticles encapsulated of <i>Catharanthus roseus</i> L. extracts</b></p> <p><u>De Silva WND</u><sup>1*</sup>, Attanayake AP<sup>1</sup>, Arawwawala LDAM<sup>2</sup>, Karunaratne DN<sup>3</sup>, Pamunuwa KMGK<sup>4</sup></p> <p><sup>1</sup>Department of Biochemistry, Faculty of Medicine, University of Ruhuna, Sri Lanka, <sup>2</sup>Industrial Technology Institute, Sri Lanka, <sup>3</sup>Department of Chemistry, Faculty of Science, University of Peradeniya, Sri Lanka, <sup>4</sup>Department of Horticulture and Landscape Gardening, Faculty of Agriculture and Plantation Management, Wayamba University of Sri Lanka, Sri Lanka.</p>                                                              |

|     |              |                                                                                                                                                                                                                                                                                                                                                                                                                                                                                                                                                                                                                                                 |
|-----|--------------|-------------------------------------------------------------------------------------------------------------------------------------------------------------------------------------------------------------------------------------------------------------------------------------------------------------------------------------------------------------------------------------------------------------------------------------------------------------------------------------------------------------------------------------------------------------------------------------------------------------------------------------------------|
| 60. | <b>PP 55</b> | <b><i>In vitro</i> antioxidant potential of <i>Hemidesmus indicus</i> (Iramusu)</b><br>Madhuranga HDT <sup>1*</sup> , Gunasena GKBCM <sup>1</sup> , Dharmasena WASH <sup>1</sup> , Thambiliyagoda TGKU <sup>1</sup> , Riham MCM <sup>1</sup> , Samarakoon DNAW <sup>1</sup> , Herath HMLPB <sup>2</sup><br><sup>1</sup> Department of Biomedical Science, Faculty of Health Science, KAATSU International University (KIU), Sri Lanka, <sup>2</sup> Department of Chemistry, Faculty of Science, University of Colombo, Sri Lanka.                                                                                                              |
| 61. | <b>PP 56</b> | <b>Evaluation of online pharmacies operating in Sri Lanka</b><br>Hansanie SMN <sup>1*</sup> , Mannapperuma U <sup>1</sup><br><sup>1</sup> Department of Pharmacology, Faculty of Medicine, University of Colombo, Sri Lanka.                                                                                                                                                                                                                                                                                                                                                                                                                    |
| 62. | <b>PP 57</b> | <b>Determination of <i>in-vitro</i> antioxidant potential of <i>Hylocereus polyrhizus</i> seeds</b><br>Kalidha Farween MR <sup>*</sup> , Jayani DKD, Madhuranga HDT, Samarakoon DNAW<br>Department of Biomedical Sciences, Faculty of Health Sciences, KAATSU International University (KIU), Sri Lanka.                                                                                                                                                                                                                                                                                                                                        |
| 63. | <b>PP 58</b> | <b>Level of medication adherence among adult patients with chronic kidney disease attending Teaching Hospital Karapitiya</b><br>Nadeesha NVP, Prabhashini HLP, Priyadarshani SVGN, Kandambi THS, Madhumali DH, Hasanthika WWR, Nisansala MWN, Senarath NSASN<br><sup>1</sup> Department of Nursing, Faculty of Nursing, KAATSU International University (KIU), Sri Lanka.                                                                                                                                                                                                                                                                       |
| 64. | <b>PP 59</b> | <b>Development, translation, and validation of a pharmacy literacy tool for English or Sinhala speaking population</b><br>Wijesinghe DS <sup>*</sup> , Senadheera GPSG, Samaranayake NR<br>Department of Pharmacy and Pharmaceutical Sciences, Faculty of Allied Health Sciences, University of Sri Jayewardenepura, Sri Lanka.                                                                                                                                                                                                                                                                                                                 |
| 65. | <b>PP 60</b> | <b>Development of indicators for medication safety during administration of medicines by healthcare professionals and patients in Sri Lanka</b><br>Weliwatte IP <sup>1*</sup> , Samaranayake NR <sup>2</sup> , Jayawardane P <sup>1</sup> , Galappatthy P <sup>3</sup><br><sup>1</sup> Department of Pharmacology, Faculty of Medical Sciences, University of Sri Jayewardenepura, Sri Lanka, <sup>2</sup> Department of Pharmacy and Pharmaceutical Sciences, Faculty of Allied Health Sciences, University of Sri Jayewardenepura, Sri Lanka, <sup>3</sup> Department of Pharmacology, Faculty of Medicine, University of Colombo, Sri Lanka. |
| 66. | <b>PP 61</b> | <b>Evaluation of cosmetic skin cream labels available in Sri Lanka</b><br>Jayasekara ST, Senadheera GPSG, Samaranayake NR, Nadeshkumar A <sup>*</sup><br>Department of Pharmacy and Pharmaceutical Sciences, Faculty of Allied Health Sciences, University of Sri Jayewardenepura, Sri Lanka.                                                                                                                                                                                                                                                                                                                                                   |
| 67. | <b>PP 62</b> | <b>Labeling practice and associated factors of community pharmacies at municipality areas in Jaffna and Kandy Districts</b><br>Peiris DAAY <sup>1</sup> , Madhushika WT <sup>1</sup> , Udabage UGDE <sup>1</sup> , Thuvaragan S <sup>1*</sup> , Sanchayan K <sup>2</sup><br><sup>1</sup> Department of Pharmacy, Faculty of Allied Health Sciences, University of Jaffna, Sri Lanka, <sup>2</sup> Department of Pharmacology, Faculty of Medicine, University of Jaffna, Sri Lanka.                                                                                                                                                             |
| 68. | <b>PP 85</b> | <b>Anticandidal activity of antimicrobial peptide “Octominin” encapsulated chitosan nanoparticles</b><br>Jayathilaka EH <sup>1</sup> , Nikapitiya CL <sup>1</sup> , Wang I <sup>2</sup> , De Zoysa M <sup>1*</sup>                                                                                                                                                                                                                                                                                                                                                                                                                              |

|                                                                    |              |                                                                                                                                                                                                                                                                                                                                                                                                                                                                                                                                                                                                                               |
|--------------------------------------------------------------------|--------------|-------------------------------------------------------------------------------------------------------------------------------------------------------------------------------------------------------------------------------------------------------------------------------------------------------------------------------------------------------------------------------------------------------------------------------------------------------------------------------------------------------------------------------------------------------------------------------------------------------------------------------|
|                                                                    |              | <sup>1</sup> College of Veterinary Medicine and Research Institute of Veterinary Medicine, Chungnam National University, Daejeon 34134, Republic of Korea, <sup>2</sup> National Marine Biodiversity Institute of Korea (MABIK), Seochun-gun, 33662, Republic of Korea.                                                                                                                                                                                                                                                                                                                                                       |
| <b>Session VI - Health, Nutrition &amp; Laboratory Diagnostics</b> |              |                                                                                                                                                                                                                                                                                                                                                                                                                                                                                                                                                                                                                               |
| 69.                                                                | <b>PP 74</b> | <b>Detection of the effects on platelet indices of COVID-19 patients at University Hospital General Sir John Kotelalwala Defence University</b><br><u>Kumarasinghe RDKK</u> <sup>1*</sup> , Ranasinghe HN <sup>1</sup> , Jayawardana KGKG <sup>1</sup> , Kottahachchi DU <sup>1</sup> , Somaratne I <sup>2</sup><br><sup>1</sup> Department of Medical Laboratory Sciences, Faculty of Allied Health Sciences, Sir John Kotelalwala Defence University, Rathmalana, Sri Lanka, <sup>2</sup> Department of Para Clinical Sciences, Faculty of Medicine, General Sir John Kotelawala Defence University, Rathmalana, Sri Lanka. |
| 70.                                                                | <b>PP 75</b> | <b>Study of serum creatinine and uric acid in hypertensive disorders of pregnancy</b><br><u>Fawaziya HLF</u> <sup>1</sup> , Viranga AGS <sup>1</sup> , Shahmy S <sup>2</sup> , Jayawardane MAMM <sup>3</sup> , Withanage ND <sup>1*</sup><br><sup>1</sup> Department of Medical Laboratory Sciences, Faculty of Allied Health Sciences, University of Sri Jayewardenepura, Sri Lanka, <sup>2</sup> National Science and Technology Commission, Sethsiripaya, Sri Lanka, <sup>3</sup> Department of Obstetrics and Gynaecology, Faculty of Medical Sciences, University of Sri Jayewardenepura, Sri Lanka.                     |
| 71.                                                                | <b>PP 76</b> | <b>Determination of the bacterial growth and the contamination level in reusing household plastic containers among a group of undergraduates</b><br><u>Nusla MKF</u> <sup>1</sup> , Wickrama Arachchi WANL <sup>1</sup> , Bandara AWMKK <sup>2*</sup> , Nandapala JHYP <sup>1</sup><br><sup>1</sup> Department of Biomedical Sciences, Faculty of Health Sciences, KAATSU International University (KIU), Sri Lanka, <sup>2</sup> Department of Basic Sciences, Faculty of Allied Health Sciences, General Sir John Kotelawala Defense University, Werahera, Sri Lanka.                                                       |
| 72.                                                                | <b>PP 77</b> | <b>Association between body mass index with blood pressure and body fat percentage in undergraduates of University of Sri Jayewardenepura</b><br><u>Shamindri BHN</u> <sup>1</sup> , Abeywickrama HN <sup>1</sup> , Perera PPR <sup>2*</sup><br><sup>1</sup> Department of Medical Laboratory Sciences, Faculty of Allied Health Sciences, University of Sri Jayewardenepura, Sri Lanka, <sup>2</sup> Department of Biochemistry, Faculty of Medical Sciences, University of Sri Jayewardenepura, Sri Lanka.                                                                                                                  |
| 73.                                                                | <b>PP 78</b> | <b>Consumer perception on food consumption and non-communicable Diseases</b><br><u>Siriwardana EKDKC</u> <sup>*</sup> , Chandrasekara A<br>Wayamba University of Sri Lanka.                                                                                                                                                                                                                                                                                                                                                                                                                                                   |
| 74.                                                                | <b>PP 79</b> | <b>Association between serum uric acid and microalbuminuria in type 2 diabetic patients attending diabetic centre at Teaching Hospital, Jaffna.</b><br>Kayathri V <sup>1</sup> , Kinthuja N <sup>1</sup> , Abirami M <sup>1</sup> , Kesavan V <sup>2</sup> , Aravindan M <sup>3</sup> , Jaikrishna B <sup>1</sup><br><sup>1</sup> Department of Medical Laboratory Sciences, Faculty of Allied Health Sciences, University of Jaffna, Sri Lanka, <sup>2</sup> Department of Chemical Pathology, Teaching Hospital, Jaffna, Sri Lanka, <sup>3</sup> Diabetic Centre, Teaching Hospital, Jaffna, Sri Lanka.                     |
| 75.                                                                | <b>PP 80</b> | <b>Attitudes and perception towards body image concerns and eating practices among students at a selected educational institute, Gampaha District, Sri Lanka</b><br><u>Seneviratne DBR</u> <sup>1*</sup> , Kaldera HPSR <sup>2</sup><br><sup>1</sup> School of Biomedical Sciences, International Institute of Health Sciences, Welisara, Sri Lanka, <sup>2</sup> School of Nursing, International Institute of Health Sciences, Welisara, Sri Lanka.                                                                                                                                                                         |

|     |              |                                                                                                                                                                                                                                                                                                                                                                                                                                                                                                                                                                                                                                                                                   |
|-----|--------------|-----------------------------------------------------------------------------------------------------------------------------------------------------------------------------------------------------------------------------------------------------------------------------------------------------------------------------------------------------------------------------------------------------------------------------------------------------------------------------------------------------------------------------------------------------------------------------------------------------------------------------------------------------------------------------------|
| 76. | <b>PP 81</b> | <p><b>Clinical manifestation of COVID-19 and the association of vital body parameters with chronic diseases and vaccination among infected patients</b><br/> Rathnakumara MPB<sup>1</sup>, Gunarathne RTM<sup>1</sup>, Dayananda RGTN<sup>1</sup>, Sasithanjali MVM<sup>1</sup>, Indrachapa DM<sup>1</sup>, Perera KSA<sup>2</sup>, Samaranada HMVA<sup>2*</sup>, Nisansala MWN<sup>1</sup>, Senarath NSASN<sup>1</sup><br/> <sup>1</sup>Department of Nursing, Faculty of Nursing, KAATSU International University (KIU), Sri Lanka, <sup>2</sup>Department of Medical Science in Acupuncture, Faculty of Health Sciences, KAATSU International University (KIU), Sri Lanka.</p> |
| 77. | <b>PP 82</b> | <p><b>Explore the effect of fist clenching during blood collection in the measurement of serum calcium</b><br/> Vathsala S<sup>1*</sup>, Vibeeshan T<sup>1</sup>, Umasuthan U<sup>1</sup>, Balakittnen J<sup>1</sup>, Sivakumar H<sup>2</sup><br/> <sup>1</sup>Department of Medical Laboratory Sciences, Faculty of Allied Health Sciences, University of Jaffna, Sri Lanka, <sup>2</sup>Department of Pathology, Faculty of Medicine, University of Jaffna, Sri Lanka.</p>                                                                                                                                                                                                      |
| 78. | <b>PP 83</b> | <p><b>An evaluation of adulteration in chili powder sold in shops in the Peliyagoda urban council area</b><br/> Pushpakumara PAYN<sup>1*</sup>, Gunawardhana VSS<sup>1</sup>, Tharaka MGGS<sup>1</sup>, Paranawithana SND<sup>1</sup>, Rajendran MR<sup>1</sup>, Samarakoon N<sup>1</sup>, Jayawickrama DR<sup>2</sup><br/> <sup>1</sup>Department of Biomedical Science, Faculty of Health science, KAATSU International University (KIU), Sri Lanka, <sup>2</sup>Department of Animal Science, Faculty of Animal Science and Export Agriculture, Uva Wellassa University of Sri Lanka, Sri Lanka.</p>                                                                           |
| 79. | <b>PP 84</b> | <p><b>Knowledge of street food safety among the students in a private university in Colombo, Sri Lanka</b><br/> Kodikara VS, De Silva RM, Nandapala JHYP, Ranadeva NDK<br/> Department of Biomedical Science, Faculty of Health Sciences, KAATSU International University (KIU), Sri Lanka.</p>                                                                                                                                                                                                                                                                                                                                                                                   |
| 80. | <b>PP 86</b> | <p><b>Immune modulatory activity of exosomes isolated from <i>Streptococcus parauberis</i> infected olive flounder (<i>Paralichthys olivaceus</i>) plasma</b><br/> Jayathilaka EHTT, De Zoysa M, Nikapitiya C<sup>*</sup><br/> College of Veterinary Medicine and Research Institute of Veterinary Medicine, Chungnam National University, Daejeon 34134, Republic of Korea</p>                                                                                                                                                                                                                                                                                                   |

## **Abstract Reviewers – International Research Conference in Health Sciences 2023**

|                                  |                             |
|----------------------------------|-----------------------------|
| Prof. D.M.S. Fernando            | Dr. M.R.S. Jayathilake      |
| Prof. D.I. Uluwaduge             | Mr. M.A. Siriwardhene       |
| Prof. P.P.R. Perera              | Dr. W.J.A.B.N. Jayasuriya   |
| Prof. S.W. Wimalasekera          | Dr. N.D. Withanage          |
| Prof. Chinthika Gunasekara       | Dr. A. Nadeshkumar          |
| Prof. C.S.E. Goonawardena        | Dr. Damayanthi Dassanayake  |
| Prof. Usha Hettiarachchi         | Dr. G. Kisokanth            |
| Prof. R.B. Marasinghe            | Dr. G.P.S.G. Senadheera     |
| Prof. J. Kottahachchi            | Dr. H.M. Kasuni Akalanka    |
| Prof. M.M. Weerasekera           | Dr. I. Munaweera            |
| Prof. A.A.T.D. Amarasekara       | Dr. I.M.P.S. Iankoon        |
| Prof. T.S. Suresh                | Dr. R.M.T.B. Abeyratne      |
| Prof Lohini Aththithan           | Dr. K.A.A. Dilhari          |
| Prof. Shalindra Ranasinghe       | Dr. D.I.G. Rajapakshe       |
| Prof. N.R. Samaranyake           | Dr. Kalpani Abhayasinghe    |
| Prof Anoja Attanayake            | Dr. Kalpani Ratnayake       |
| Prof. Swarna Hapuarachchi        | Dr. Tharindu Senapathi      |
| Prof. A. M. S. D. M. Dissanayake | Dr. Sjith Edirisinghe       |
| Prof. Sakeena Hameen             | Dr. K.A. Sriyani            |
| Dr. S.M.K.S Seneviratne          | Dr. K.D.K. Peshala Kumari   |
| Prof. A.M.B. Priyadarshani       | Dr. L.G.T. Darshana         |
| Dr. Maduka De Lanerolle Dias     | Dr. Madhavi N. Pahalagedara |
| Dr. Chamarika Moonasinghe        | Dr. N. Perera               |
| Dr. Himani Molligoda             | Dr. Ranga K. Dissanayake    |
| Dr. M.K.D.L. Meegoda             | Dr. R.H.M.P.N. Rathnayake   |
| Dr. G.U.S. Wijesekara            | Dr. S.M.T.D. Sundarapperuma |
| Dr. H.M.D.R. Herath              | Dr. Saraji Wijesekara       |

Dr. W.N. Priyanthi

Dr. Indika Senevirathna

Dr. Harith Eranga Yapa

Dr. Nirmala Priyadarshani

Dr. D.T. Wijeratne

Dr. Nalini Somaweera

Dr. Pramudi kariyawasam

Dr. Anusha Jatheesan

Dr. Gayathri Rathnayaka

Dr. Chandima Kulathilaka

Dr. Thushari Dissanayake

Dr. Kithsiri Jayasekara

Dr. Dinithi Vidanage

Dr. Darshana Kottahachchi

Dr. Vindya Pathiraja

Dr. Shashika Karunanayake

Dr. Thanuja Asurakkodi

Ms. Janani Buddhika

Dr. Thuvaragan Sinnadurai

Dr. K.L.M.D. Seneviwickrama

Dr. Ashwinie de Abrew

Dr. Chamila Liyanaarachchie

Dr. L.G.T. Shanika

Dr. Prasadini Perera

Dr. Uthpali Mannapperuma

Dr. Jayamal de Silva

Dr. Dulshika wass

Ms. L.C. Damayanthi

Ms. P.W.G.D.P. Samarasekara

Mr. Rahal Widanagamage



**Range of Products Dedicated to Cell Culture, Cell preparation, Separation & Stimulation.**



**An Array of Products in Proteomics**

**Products & Services Aligned for Molecular Life Sciences**

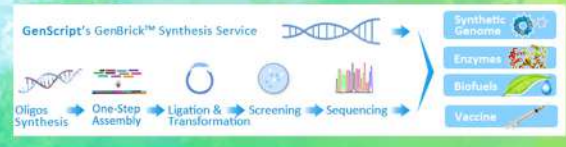

**BIOMEDITE (PVT) LTD**

No.276/2A, Hospital Road, Kalubowila, Dehiwala.

Web : [www.biomedite.lk](http://www.biomedite.lk) E-mail : [info@biomedite.lk](mailto:info@biomedite.lk)

Call : 011 2763990

Fax : 011 2763286

' Contact us today to partner with leading global brands for medical, biotech & analytical devices '

# The strength of a nation



Superior Strength | Greater Durability | Superior Workability | Water Protect | Environmentally Friendly



High-strength

## INSEE Sanstha Composite Cement



Level 25, Access Tower 02, 278/4, Union Place, Colombo 02.  
TEL: +94 11 7800 801 | FAX +94 11 2505 280  
Email: callcenter-lka@siamcitycement.com  
WEB: www.siamcitycement.lk



## Best compliments from

Sri Lanka's fastest growing pharmaceutical and healthcare products supply and distribution company with an ever growing global reach, achieved through the unwavering strength built over a decade of experience.

**SK·F**  
ESKAYEF PHARMACEUTICALS LTD.  
| www.eskfbd.com |

**BIOPHARMA**  
LIMITED

**Saffron**  
Pharmaceutical (Pvt.) Ltd.

**Astron** Limited

**Adnova**  
HEALTHCARE PVT. LTD.

**FM**  
HAWAHI LAROPATOWA LIMITED



[www.truviclanka.com](http://www.truviclanka.com)



HEAD OFFICE  
TRUVIC (PVT) LIMITED  
No: 147/5D, Kalalgoda Road, Pannipitiya, 10230, Sri Lanka.  
Tel : +94 11 43 444 68 Fax : + 94 11 434 68 60  
[info@truviclanka.com](mailto:info@truviclanka.com)

INTERNATIONAL OFFICE  
TRUVIC DMCC  
Unit No: 488, DMCC Business Centre, Level No 1, Jewellery & Gemplex 3,  
Dubai, UAE. Tel: +94 777 277 010

BRANCH OFFICE TRUVIC CO., LIMITED  
No: 244 B, Street 376, Sangkat Boeung Keng Kang 3,  
Khan Chamkaramon, Phnom Penh, 12310, Cambodia.  
Tel: +855 96 434 4953



**INTERNATIONAL RESEARCH CONFERENCE IN HEALTH SCIENCES 2023**

**Faculty of Allied Health Sciences  
University of Sri Jayewardenepura  
Nugegoda - Sri Lanka**